

Owner's Manual
2024 Q4 e-tron

Foreword

Thank you for choosing an Audi – we value your trust in us.

Your new Audi will allow you to experience the best in groundbreaking technology and premium quality equipment that a vehicle has to offer. Audi recommends that you read your Owner's Manual thoroughly so that you quickly become acquainted with your Audi and make use of all of its features.

In addition to explaining how the different features work, there are many useful tips and information concerning your safety, how to care for your vehicle, and how to maintain your vehicle's value. Audi also gives you useful tips and information on how to drive your vehicle more efficiently and in an environmentally-friendly manner.

Audi hopes you enjoy driving your vehicle and wishes you safe and pleasant motoring.



WARNING

Operating, servicing and maintaining a passenger vehicle or off-highway motor vehicle can expose you to chemicals including phthalates and lead, which are known to the State of California to cause cancer and birth defects or other reproductive harm. To minimize exposure, wear gloves or wash your hands frequently when servicing your vehicle. For more information go to www.P65Warnings.ca.gov/passenger-vehicle.

Table of contents

About this Owner's Manual	5	Lights and vision	49
Summary	6	Exterior lighting	49
Quick access	6	Interior lighting	53
Online information	6	Vision	54
FAQ	7	Windshield wipers	56
Cockpit	9	Digital compass	58
Indicator lights overview	10	Sitting correctly and safely	60
Display and operation	14	Maintaining the correct seating position .	60
Instrument cluster	14	Front seats	60
Instrument cluster overview	14	Steering wheel	63
Operating	14	Head restraints	63
Adjusting the display	15	Safety belts	65
Power meter	16	Memory function	68
Odometer	16	Airbag system	68
Outside temperature display	16	Child safety seats	73
Vehicle functions	16	Storage and convenience	79
Touch display	18	Power sources	79
General touch display operation	18	Cup holders	79
Multi Media Interface	20	Storage and compartments	80
Head-up display	26	Luggage compartment	80
Description	26	Roof rack	83
Voice recognition system	27	Warm and cold	84
General information	27	Climate control system	84
Description	27	Steering wheel heating	87
External voice operation	28	Auxiliary climate control	88
Global functions	30	Fluids in the A/C system	89
Additional function buttons	30	Driving	90
Starting and driving	31	Starting the vehicle	90
Personalization	31	When driving	91
Users	31	Drive system	93
Opening and closing	33	Brakes	95
Central locking	33	Electromechanical parking brake	97
Keys	37	Special driving situations	98
Luggage compartment lid	39	Driving dynamic	100
Child safety lock	43	Audi drive select	100
Power windows	44	Suspension	100
Panoramic glass roof	45	Steering	101
Garage door opener	45	All wheel drive (quattro)	102
		Electronic Stabilization Control	102
		High-voltage system	105
		General information	105
		Charging the high-voltage battery	106

Charging settings	112	Audi connect	185
Charging equipment	116	General information	185
Trailer towing	125	Audi connect Infotainment	186
Driving with a trailer	125	Using a Wi-Fi hotspot	186
Trailer hitch	126	Audi connect Infotainment services	186
Assist systems	129	Audi connect vehicle control services	187
Assist systems	129	Settings	188
General information	129	Troubleshooting	189
Surrounding area detection	130	Emergency call	190
Driver assistance menu	132	Overview	190
Parking aid menu	133	Emergency call	190
Driving information	134	Online roadside assistance	191
Speed warning system	134	Navigation	192
Camera-based traffic sign recognition ...	134	Opening navigation	192
Traffic light information	136	myAudi navigation	192
Driver assistance	138	Entering a destination	193
Cruise control system	138	Stopping route guidance	197
Efficiency assist	139	Map	197
Adaptive cruise assist	141	Predictive route guidance	199
Distance warning	151	Alternative routes	199
Lane departure warning	151	Additional functions	200
Audi pre sense	153	Satellite map	200
Side assist	156	Electric range	201
Exit warning	158	Map update	201
Emergency assist	159	Traffic information	202
Parking and maneuvering	161	Settings	203
Introduction	161	Radio	205
Parking aid plus	161	General information	205
Rearview camera and peripheral cameras .	163	Radio functions	206
Rear cross-traffic assist	167	Online radio	209
Assisted parking	168	Options and settings	210
Park assist plus	170	Troubleshooting	211
Infotainment system	174	Media	212
Telephone	174	General information	212
Introduction	174	Bluetooth audio player	212
Setup	174	Amazon Alexa	213
Using the Audi phone box	176	Multimedia connections	213
Using the telephone	178	Playing media	214
Settings	182	Options and settings	217
Messages	183	Supported media and file formats	218
Troubleshooting	184	Troubleshooting	219
Interactive experience	221	Themes	221

Table of contents

Smartphone interface	222	Data memories	281
Setup	222	Transmitted information	282
Troubleshooting	223		
Additional settings	225	Accessories and technical	
System settings	225	changes	285
Software update	226	Warranty	285
Connected devices	227	Audi Literature Shop	285
Legal information	228	Driving in other countries	285
Maintenance and Care	229	Maintenance, repairs, and technical	
Checking and Filling	229	modifications	285
Front compartment	229	Accessories and parts	287
Cooling system	232	Reporting Safety Defects	287
Brake fluid	234		
Electrical system	235	Technical data	289
Battery	236	Identification data	289
Windshield washer system	239	Vehicle data	289
Service interval display	239		
Wheels	241	Other information	291
Tires and rims	241	Brands and licenses	291
Tire pressure monitoring system	258	Disposal instructions	291
		Declaration of compliance for	
Care and cleaning	261	telecommunications equipment and	
General information	261	electronic systems	291
Car washes	261		
Cleaning and care information	262	Index	293
Taking your vehicle out of service	267		
Do It Yourself	268		
Emergency assistance	268		
General information	268		
Equipment	268		
Tire mobility kit	268		
Changing a tire	270		
Jump starting	272		
Towing	274		
Fuses and bulbs	278		
Fuses	278		
Bulbs	280		
Customer information	281		
Data privacy	281		
Privacy notice	281		
Image recording	281		

This manual contains important information, safety precautions, and tips for using your vehicle.

READ THIS OWNER'S MANUAL AND KEEP IT!

Read this Owner's Manual carefully before using your vehicle. Keep this manual and any other applicable documents in your vehicle at all times. This is especially important if you loan your vehicle to others or sell it.

Updates to the Owner's Manual: Please note that it has always been Audi's¹⁾ policy to continuously improve its products. Audi reserves the right to make changes in design and specifications, and to make additions or improvements in its products without incurring any obligation to install them on products previously manufactured. Changes by means of software updates may be possible, depending on the vehicle and market. Therefore, it is also possible that the Owner's Manual may be updated. This will be done in the form of supplements. Supplements may be provided to you in both printed and digital form. Notes in the supplement will indicate if a digital or printed supplement applies to you.

Vehicle-specific features: Standard equipment, equipment for specific markets, and special equipment that is available for the entire model line is described. In addition, it is possible that some of the equipment and functions will only be available at a later time or they may only be available in certain markets. Therefore, the descriptions also include items that are not available in your specific vehicle. The illustrations in this manual are a guide. Some of the details in your vehicle may differ from the illustrations. Text, illustrations, and specifications are based on the most current information available at the time of printing, and shall not constitute a basis for liability claims.

Identifying if information is applicable: Some sections do not apply to all vehicles. When this is the case, the beginning of the section indicates the applicability, for example "Applies to:

vehicles with speed warning system". In addition, optional or vehicle-specific equipment and functions may be indicated with an asterisk "*" or a corresponding comment (such as "depending on vehicle equipment").

Symbols and standards for descriptions in the Owner's Manual:

- * Optional or vehicle-specific equipment
- ▶ The section continues on the next page.
- ⇒ *page 68* Cross reference to other descriptions or topics.
- ⇒ ⚠ Cross reference to a "WARNING".

Directions, such as "left", "right", "front" and "rear", are based on the vehicle's direction of travel.

WARNING

Text with this symbol contains information about safety and how to reduce the risk of serious personal injury or death.

Note

Text with this symbol contains information about reducing the risk of damage to your vehicle.

For the sake of the environment

Text with this symbol contains information on protecting the environment.

Tips

Text with this symbol contains additional useful information.

¹⁾ "Audi" refers to AUDI AG, the respective importer in a country, as well as joint ventures.

Quick access

Online information

myAudi

You can access the digital form of your Owner's Manual on your mobile device using myAudi.

Requirement: you must have a registered myAudi account. Your vehicle must be registered in your myAudi account.

- ▶ Visit my.audi.com, or
- ▶ Start the myAudi app on your mobile device.

Online Owner's Manual

Applies to: vehicles with Online Owner's Manual

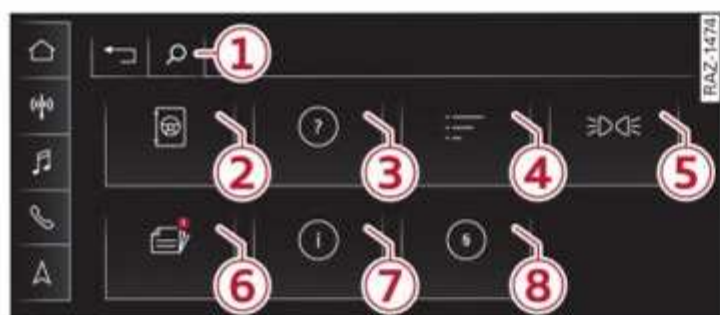

Fig. 1 Center display: Online Owner's Manual

The Online Owner's Manual can be accessed directly from the Owner's Manual in the Infotainment system. Each time you access the Owner's Manual, it will automatically display in the language that is set for your MMI.

Accessing the Online Owner's Manual

Requirement: the vehicle must be stationary.

- ▶ Applies to: MMI: Select on the home screen: **HELP > Owner's manual**.

Functions and operation

① Free text search

Using the free text search, you can search for terms in the entire contents of the Owner's Manual. The search results will be grouped based on their topic.

- Press the button and enter the desired search term.

② Chapter

You can display the contents of the Owner's Manual sorted by topic.

③ FAQ

In order to get to know your vehicle, you can find answers to frequently asked questions in the FAQ section.

④ Index

Using the index, you can search for a specific term and quickly access relevant information.

⑤ Indicator lights

An overview of all available indicator lights and their meanings will be displayed.

- Press on any indicator light to display its meaning.

⑥ Supplements

Supplements will be created if changes to the Owner's Manual are necessary. The **Supplements** menu will only appear if supplements are available. A notification icon displays the number of supplements that are available. This icon will disappear once the **Supplements** menu has been opened.

⑦ Info

An overview of general information about the Owner's Manual will be displayed. You can also change the language in which the Online Owner's Manual content is displayed. The language will be reset when you exit the Online Owner's Manual.

Change language

- Applies to: MMI: Select on the home screen: **HELP > Owner's manual > Info > Change language**.

⑧ Legal notes

An overview of all legal notes pertaining to the Online Owner's Manual will be displayed.

WARNING

To reduce the risk of an accident, only use the Online Owner's Manual when the vehicle is parked safely.

Tips

The content is the information that was available at the time of the editorial deadline for this manual. There may be changes over the service life of the vehicle.

FAQ

Before driving

- How do I adjust the seat? ⇒ *page 60.*
- How do I adjust the steering wheel? ⇒ *page 63.*
- How does the selector lever work? ⇒ *page 92.*
- What is a gear and a driving program? ⇒ *page 92.*
- How does the electromechanical parking brake work? ⇒ *page 97.*
- How can I maintain the vehicle's rolling ability? ⇒ *page 97.*
- How do I adjust the exterior mirrors? ⇒ *page 54.*
- How do I operate windshield wipers with the rain sensor? ⇒ *page 56.*
- Where is the washer fluid reservoir located? ⇒ *page 232.*
- How do I store the tire pressures? ⇒ *page 260.*
- How do I drive with a trailer? ⇒ *page 125.*

e-tron

- How do I start my vehicle? ⇒ *page 90.*
- When starting to drive, what do I need to pay attention to on an electric vehicle? ⇒ *page 91.*
- How can I recover energy through recuperation while driving? ⇒ *page 93.*
- What can I operate using the shift paddles on an electric vehicle? ⇒ *page 93.*
- How can I find the nearest charging station? ⇒ *page 193.*
- What are the options for charging my vehicle? ⇒ *page 106.*
- How do I charge my vehicle? ⇒ *page 109.*
- How can I set a maximum charge limit for the high-voltage battery? ⇒ *page 113.*
- How do I end a charging process? ⇒ *page 109.*
- What do the colors of the LED on the charging unit mean? ⇒ *page 110.*
- How can I set specific charging times for my vehicle? ⇒ *page 114, Timer.*

Vehicle breakdowns and emergencies

- Where can I find the correct tire pressure? ⇒ *page 252.*
- How do I jump start my vehicle? ⇒ *page 272.*
- What type of airbags are equipped in my vehicle? ⇒ *page 68.*
- Where are the towing loops located on the vehicle? ⇒ *page 274.*
- How do I manually unlock the charging connector? ⇒ *page 111.*

Advanced functions

- How is the distance to the vehicle driving ahead of me automatically maintained? ⇒ *page 141, Adaptive cruise assist.*
- How does the adaptive cruise assist respond automatically to speed limits and road conditions? ⇒ *page 146.*
- How can I stay in the lane more easily? ⇒ *page 145.*
- How can I be warned when leaving a lane? ⇒ *page 151.*
- How do I use the parking aid? ⇒ *page 161.*
- How can I more safely drive through intersections and exits with poor visibility? ⇒ *page 166.*
- How can the high beam headlights be controlled automatically? ⇒ *page 50.*
- How can I monitor the blind spot more easily when changing lanes? ⇒ *page 156, Side assist.*
- How can I open the luggage compartment lid with my foot? ⇒ *page 42.*
- How can I adjust the vehicle handling based on the driving situation and my preferences? ⇒ *page 100, Audi drive select.*

Display and operation

- How do I turn on the touch display? ⇒ *page 20.*
- How do I operate the touch display? ⇒ *page 18.*
- How do I control the volume? ⇒ *page 30.*
- How do I navigate through the menus? ⇒ *page 21.*
- How do I write letters and numbers by hand? ⇒ *page 24.*

Quick access

- How do I operate functions such as the navigation by voice? ⇒ *page 27*.
- Which functions can I operate with the buttons on the steering wheel? ⇒ *page 14* or ⇒ *page 30*.
- How do I display information on the windshield? ⇒ *page 26, Head-up display*.
- How can I adjust the brightness of the instrument and display lighting? ⇒ *page 53*.
- How can I request the next service appointment? ⇒ *page 239*.

Infotainment system

- How can I connect my mobile device to use the hands-free system? ⇒ *page 174*.
- How can I switch between connected devices? ⇒ *page 227*.
- How can I access information online? ⇒ *page 185, Audi connect*.
- How can I use the Wi-Fi hotspot? ⇒ *page 186*.
- What are the different ways I can enter a navigation destination? ⇒ *page 193*.
- How can I operate the map functions? ⇒ *page 197*.
- How can I display traffic information? ⇒ *page 202*.
- How can I listen to the radio? ⇒ *page 205*.
- How can I play media? ⇒ *page 214*.
- How can I play music from my mobile device on the Infotainment system? ⇒ *page 212, Bluetooth audio player*.

Tips and tricks

- How can I unlock my vehicle from the inside for other persons to enter? ⇒ *page 35*.
- How can I open all the windows from the outside using the remote control key? ⇒ *page 44, Convenience opening and closing*.
- How can I adjust the open position of the luggage compartment lid? ⇒ *page 41*.
- How can I deactivate the front passenger's airbag? ⇒ *page 71*.
- How do I secure a child safety seat? ⇒ *page 73*.
- What should I consider when driving through a car wash? ⇒ *page 261*.
- How can I drive in a way that is efficient and environmentally-friendly? ⇒ *page 94*.

Cockpit

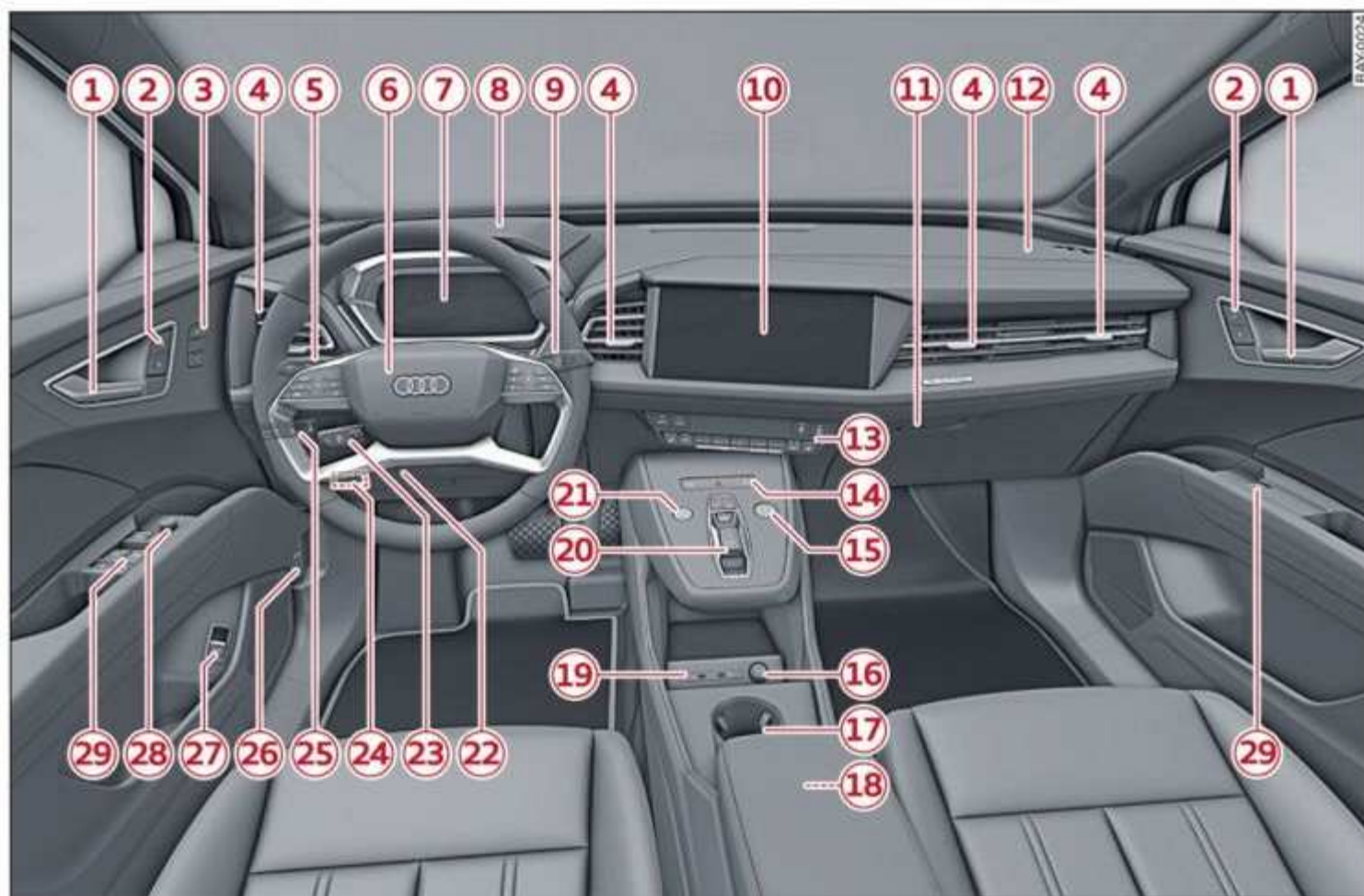

Fig. 2 Cockpit

①	Door handle		
②	Central locking switch	35	
③	Memory function buttons	68	
④	Vent		
⑤	Lever for:		
	– Turn signals and high beams	50	
	– High beam assistant	50	
	– Lane departure warning	151	
	– Lane guidance	145	
⑥	Multifunction steering wheel with:		
	– Horn		
	– Driver's airbag	68	
	– Operating buttons	14, 30	
	– Shift paddles	93	
⑦	Instrument cluster	14	
⑧	Head-up display	26	
⑨	Windshield washer system lever	56	
⑩	Center display	20	
⑪	Lockable glove compartment		
⑫	Front passenger's airbag	68	
⑬	Climate control system	84	
⑭	Depending on equipment, buttons for:		
	– drive select	100	
	– Emergency flashers	52	
	– Electronic Stabilization Control (ESC)	103	
⑮	MMI control pad	20, 30	
⑯	Socket	79	
⑰	Depending on equipment:		
	– Starting the vehicle when there is a malfunction	91	
	– Cup holder	79	
⑱	Center armrest with storage compartment		
⑲	Depending on equipment:		
	– USB ports with charging function	213	
	– Audi phone box	176	
⑳	Depending on equipment:		
	– Driver assistance systems	132	
	– Parking aids	161	▶

- Electromechanical parking brake button 97
- Selector lever 92
- 21 **START STOP** button 90
- 22 Steering wheel adjustment 63
- 23 Lever for:
 - Cruise control system 138
 - Adaptive cruise assist 141
- 24 Connection port for the On Board Diagnostic System (OBD) 281
- 25 Buttons for:
 - Lights 49
 - All-weather lights 49
- 26 Release for the hood 230
- 27 Luggage compartment lid button 39
- 28 Exterior mirror adjustment 54
- 29 Buttons for:
 - Power windows 44
 - Child safety lock 43

i **Tips**
 Some of the equipment listed here is only installed in certain models or is available as an option.

Indicator lights overview



Description

The indicator lights in the instrument cluster blink or turn on. They indicate functions or malfunctions. Some warning and indicator lights turn on when you switch the ignition on and must turn off when the drive system is switched on or while driving.

With some indicator lights, messages may appear and warning signals may sound. The indicator lights and messages may be covered by other displays. To show them again, select the second tab for messages with the multifunction steering wheel ⇒ *page 14*.







Some indicator lights in the display can display in several colors.











⚠ Central indicator light

If the  or  indicator light turns on, check the message in the instrument cluster.





Overview



















The following indicator lights may be available, depending on the vehicle equipment:

















Red indicator lights	
	Central indicator light ⇒ <i>page 10</i> , Instrument cluster ⇒ <i>page 14</i>
	Safety belt ⇒ <i>page 67</i>
A/C	Climate control system ⇒ <i>page 87</i>
	Drive system ⇒ <i>page 94</i> , ⇒ <i>page 274</i> , ⇒ <i>page 275</i> , Cooling system ⇒ <i>page 232</i> , ⇒ <i>page 233</i> , Electrical system ⇒ <i>page 235</i>
	Drive system ⇒ <i>page 94</i>
BRAKE	Brake system ⇒ <i>page 96</i> , ⇒ <i>page 234</i> , Electromechanical parking brake ⇒ <i>page 98</i>
	Brake system ⇒ <i>page 96</i> , ⇒ <i>page 234</i> , Electromechanical parking brake ⇒ <i>page 98</i>
PARK	Electromechanical parking brake ⇒ <i>page 97</i>
	Electromechanical parking brake ⇒ <i>page 97</i>
	Steering ⇒ <i>page 101</i>

	Steering lock ⇒ page 101
	Adaptive cruise assist ⇒ page 143, Brake intervention request ⇒ page 145, Safe start monitor ⇒ page 149
	Adaptive cruise assist ⇒ page 143, ⇒ page 146
	Steering intervention request (Adaptive cruise assist) ⇒ page 143, ⇒ page 146
	Distance warning ⇒ page 151
	Lane departure warning ⇒ page 152
	Lane departure warning ⇒ page 152
	Pre sense ⇒ page 154, ⇒ page 155
	Hood ⇒ page 231
	Cooling system ⇒ page 232, ⇒ page 232, ⇒ page 233, ⇒ page 274
	Electrical system ⇒ page 235

Yellow indicator lights















	Central indicator light ⇒ page 10
	Central locking ⇒ page 35
	Battery in remote control key ⇒ page 38
	Bulb failure indicator ⇒ page 52

	Adaptive light ⇒ page 52
	Headlight range control system ⇒ page 52
	Light/rain sensor ⇒ page 52, ⇒ page 58
	Windshield wipers ⇒ page 58
	Safety systems ⇒ page 69
	Climate control system ⇒ page 87
	Engine start system ⇒ page 91
	Convenience key ⇒ page 91
	Drive system ⇒ page 94, Charging system ⇒ page 112
	Drive system ⇒ page 94
	Vehicle sound ⇒ page 94
	Brake system ⇒ page 96
	Electromechanical parking brake ⇒ page 98
	Suspension control ⇒ page 101
	Steering ⇒ page 101
	Steering lock ⇒ page 101
	All wheel drive ⇒ page 102
	Electronic Stabilization Control (ESC) ⇒ page 103
	Electronic Stabilization Control (ESC) ⇒ page 103

	Electronic Stabilization Control (ESC) ⇒ page 104
ABS	Anti-lock Braking System (ABS) ⇒ page 104
	Anti-lock Braking System (ABS) ⇒ page 104
	High-voltage battery range ⇒ page 112
	Steering intervention request (Adaptive cruise assist) ⇒ page 143, ⇒ page 146, Steering intervention request (Lane departure warning) ⇒ page 153
	Adaptive cruise assist ⇒ page 150
	Distance warning ⇒ page 151
	Lane departure warning ⇒ page 153
	Pre sense ⇒ page 154
	Side assist, exit warning ⇒ page 158
	Emergency assist ⇒ page 159
	Emergency assist ⇒ page 159
	Parking aids ⇒ page 163
	Rear cross-traffic assist ⇒ page 168
	Park assist plus ⇒ page 173
	Emergency call function ⇒ page 191
	Electrical system ⇒ page 235
	Washer fluid level ⇒ page 239

	Tire pressure ⇒ page 259
TPMS	Tire pressure ⇒ page 259

Other indicator lights

	Low beam headlights ⇒ page 49
	Parking lights ⇒ page 49, ⇒ page 49
	Turn signals ⇒ page 50, ⇒ page 52
	Turn signals ⇒ page 50, ⇒ page 52
	Trailer turn signals ⇒ page 126
CRUISE	Cruise control system ⇒ page 138
	Cruise control system ⇒ page 138
	Efficiency assist ⇒ page 140, ⇒ page 140
	Efficiency assist ⇒ page 140
	Efficiency assist ⇒ page 140
	Efficiency assist ⇒ page 140
	Efficiency assist ⇒ page 140
	Adaptive cruise assist ⇒ page 143
	Adaptive cruise assist ⇒ page 143
	Adaptive cruise assist ⇒ page 143
	Adaptive cruise assist ⇒ page 143

	Adaptive cruise assist ⇒ page 143		Efficiency assist ⇒ page 140, Adaptive cruise assist ⇒ page 149, ⇒ page 150
	Lane departure warning ⇒ page 152		Adaptive cruise assist ⇒ page 143, ⇒ page 145
	Lane departure warning ⇒ page 152		Adaptive cruise assist ⇒ page 148
	Park assist plus ⇒ page 171, ⇒ page 172		Distance warning ⇒ page 151
	High beam headlights ⇒ page 50, ⇒ page 50		Lane departure warning ⇒ page 152, ⇒ page 153
	High beam assistant ⇒ page 50		Lane departure warning ⇒ page 152
	Child safety lock ⇒ page 43		Side assist, exit warning ⇒ page 158
	High beam assistant ⇒ page 50, ⇒ page 52		Emergency assist ⇒ page 159
	Convenience key ⇒ page 91		Emergency assist ⇒ page 159
	Electromechanical parking brake ⇒ page 98		Parking aids ⇒ page 163
	Electromechanical parking brake ⇒ page 98		Rear cross-traffic assist ⇒ page 168
	Brake ⇒ page 98		Park assist plus ⇒ page 173
	High-voltage battery range ⇒ page 112		Park assist plus ⇒ page 173
	Speed warning system ⇒ page 134		
	Speed warning system ⇒ page 134		
	Camera-based traffic sign recognition ⇒ page 135		
	Cruise control system ⇒ page 139		
	Cruise control system ⇒ page 139		

Instrument cluster

Instrument cluster overview



Fig. 3 Instrument cluster overview

Depending on the vehicle equipment, the following items may appear in the instrument cluster:

- | | |
|---|-----|
| ① Left dial | |
| – Power meter | 16 |
| – High-voltage battery charge level | |
| ② Tab area | 14 |
| ③ Central area | 14 |
| ④ Status bar (one or two lines) | |
| ⑤ Right dial | |
| – Convenience display | |
| ⑥ Right additional display with speedometer | |
| ⑦ Left additional display with: | |
| – Selector lever position | 92 |
| – Audi drive select mode | 100 |

- Speeds are displayed in mph (miles per hour) or km/h (kilometers per hour).
- Certain instrument cluster content can also be displayed in the head-up display*
⇒ page 26.

Operating

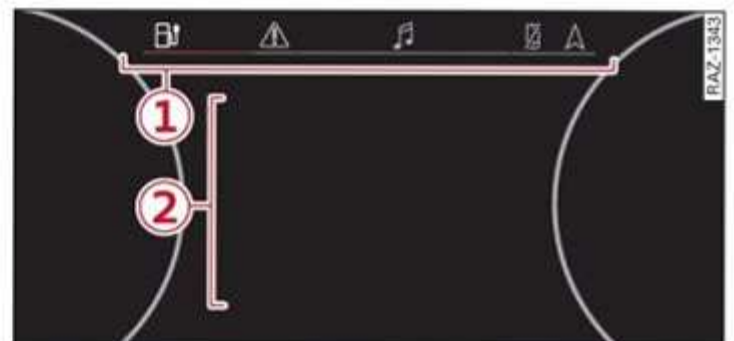

Fig. 4 Driver information system display

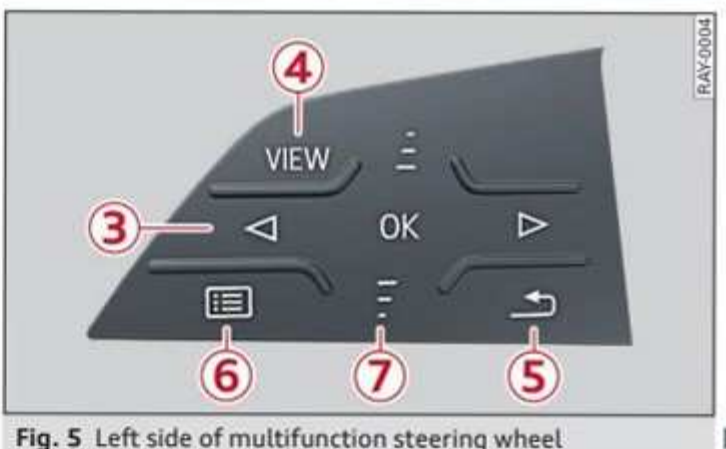



Fig. 5 Left side of multifunction steering wheel

⚠ WARNING

If there is a serious system malfunction, the display may turn off. The  indicator light may also turn on. Stop the vehicle safely. See an authorized Audi dealer or authorized Audi Service Facility for assistance.

Tips

- You can select the units used for temperature, speed, and other measurements
⇒ page 225.

Information is organized within various tabs ① in the instrument cluster. The tab contents are displayed in the central area ②.

Requirement: the ignition must be switched on.

Selecting a tab

- ▶ Press the ◀ / ▶ button ③ repeatedly until the desired tab is selected, or
- ▶ To operate using gestures, swipe your finger to the right or left in area ③ until the desired tab is selected.

Returning to functions at higher levels

- ▶ Press the ↶ button ⑤.

Opening and closing the menu

- ▶ Press the ☰ button ⑥.

Selecting and confirming a function

Requirement: a menu or list must be displayed.



- ▶ To select a function, press the ⏪ / ⏩ button ⑦ repeatedly until the desired function is selected, or
- ▶ To operate using gestures, swipe your finger up or down in area ⑦ until the desired function is selected.
- ▶ To confirm a selection, press **OK**.

Switching the view

- ▶ Press the VIEW button ④ ⇨ *page 15*.

Overview of the tabs

Depending on vehicle equipment, the following tabs may be available:

Symbol	Description
	Vehicle functions
	Driver messages (this is only displayed if at least one indicator light/message is being displayed)
	Multimedia
	Telephone
	Navigation

Adjusting the display

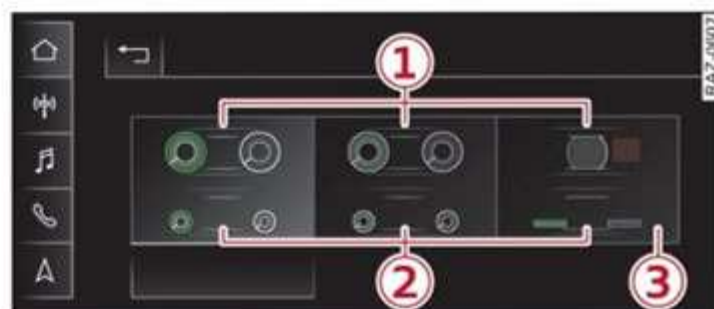

Applies to: Audi virtual cockpit

Fig. 6 Center display: adjusting the display

Depending on vehicle equipment, you may be able to change the view or the layout in the Audi virtual cockpit.

Switching the view

- ▶ Press the VIEW button to switch between the default view ① and the enhanced view ②.

Adjusting the layout

Depending on the vehicle equipment, various layouts may be available.

- ▶ Applies to: MMI: Select on the home screen: **SETTINGS > Display & Brightness > Audi virtual cockpit**.
- ▶ To adjust the desired layout, press ③.

Adjusting the additional display

Depending on the vehicle equipment, the additional displays that can be selected may vary.

- ▶ Applies to: MMI: Select on the home screen: **SETTINGS > Display & Brightness > Audi virtual cockpit > Configure**.
- ▶ Select the desired additional display.

Reducing the display

- ▶ Select on the instrument cluster: vehicle functions tab > ☰ button > **Reduced display**.
- ▶ Depending on vehicle equipment, you can press the VIEW button on the multifunction steering wheel.

Power meter



Fig. 7 Instrument cluster: power meter

The power meter ① ⇒ page 14 gives feedback about the usage capacity of the drive system. The power meter needle displays the current usage capacity.

A colored border indicates how much the drive system can currently be utilized. The color may vary depending on the layout that is selected and the amount of electrical power that is currently available.

Depending on the vehicle equipment, the power meter displays the following driving statuses:

- ① Drive system switched off
- ② Vehicle recovering electrical energy
- ③ Drive system switched on
- ④ Vehicle is being driven, drive system usage information in percentage
- ⑤ Vehicle is being driving and increased power is available

Odometer

The trip odometer and odometer are displayed in the status bar ④ ⇒ page 14.

The trip odometer shows the distance driven since it was last reset. It can be used to measure short distances. The odometer shows the total distance that the vehicle has been driven.

Resetting the trip odometer

- ▶ Select on the instrument cluster: vehicle functions tab > button > **Reset mi.**

Tips

Distances are displayed in mi (miles) or km (kilometers).

Outside temperature display

The outside temperature is displayed in the status bar ④ ⇒ page 14.

At temperatures below 41 °F (+5 °C), a snowflake symbol appears in front of the temperature display ⇒ .

WARNING

Do not assume the roads are free of ice based on the outside temperature display. Be aware that there may be ice on roads even when the outside temperature is around 41 °F (+5 °C) and that ice can increase the risk of accidents.

Vehicle functions

Overview

The trip computer is displayed in the first tab of the driver information system. Additional vehicle functions can be accessed depending on the vehicle equipment.

- ▶ Press the button on the multifunction steering wheel.
 - Trip computer ⇒ page 16
 - Charging
 - Reduced display ⇒ page 15
 - Reset trip odometer ⇒ page 16



Trip computer

Changing the display

- ▶ Press the button ⑦ ⇒ page 14, fig. 5 repeatedly until the desired display is shown, or
- ▶ To operate using gestures, swipe your finger up or down in area ⑦ until the desired display is shown.

Resetting values to zero

Requirement: the **Consumption**, **Short-term memory**, or **Long-term memory** display must be selected.

- ▶ To reset the values of the respective memories to zero, press and hold the  button on the multifunction steering wheel for one second, or
- ▶ Select on the instrument cluster: vehicle functions tab >  button > **Reset mi**.

Displays in the trip computer

The following displays may be shown, depending on the vehicle equipment:

- Time and date ⇒ *page 225*
- Average consumption ⇒ *page 17*
- Short-term memory overview
- Long-term memory overview
- Driver assistance ⇒ *page 142*
- Traffic sign recognition and traffic light information

Short-term memory and long-term memory

The short-term memory collects driving information from the time the ignition is switched on until it is switched off. If you continue driving within two hours after switching the ignition off, the new values will be included when calculating the current trip information.

Unlike the short-term memory, the long-term memory is not erased automatically. You can select the time period for evaluating trip information yourself.

Average consumption

The current consumption can be shown using a bar graph. The average consumption stored in the short-term memory is also displayed. If the bar is green, your vehicle is saving energy (for example, using recuperation).

Tips

The date, time of day, and time and date format can be set ⇒ *page 225*.

Touch display

General touch display operation

General information

Applies to: touch display

The center display is a touchscreen. Operation is very similar to operating a smartphone.

Tips

Certain gestures are not available in every menu.

Pressing

Applies to: touch display



Fig. 8 Touch display: pressing

Selecting a function or button

- ▶ Press the desired function or button.

Pressing and holding

Applies to: touch display



Fig. 9 Touch display: pressing and holding

Accessing options

For some items, you can access additional options that are not directly visible.

- ▶ Press and hold an item until the associated options are displayed.

Pressing and pulling

Applies to: touch display

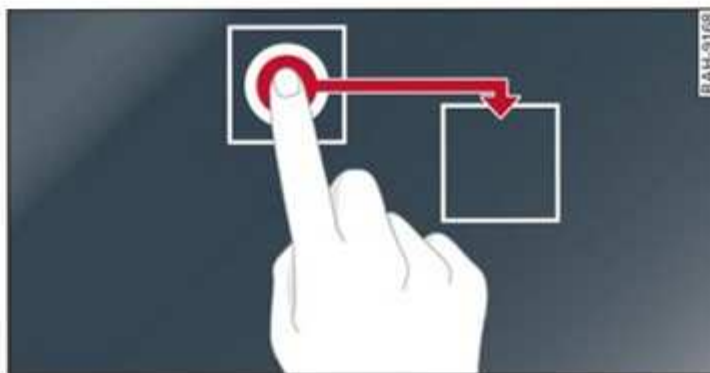

Fig. 10 Touch display: pressing and pulling

Moving an item

You can position some items at any location on the screen.

- ▶ Press and hold an item, and then use your finger to pull it to the desired location.

Pinching fingers together and pulling apart

Applies to: touch display

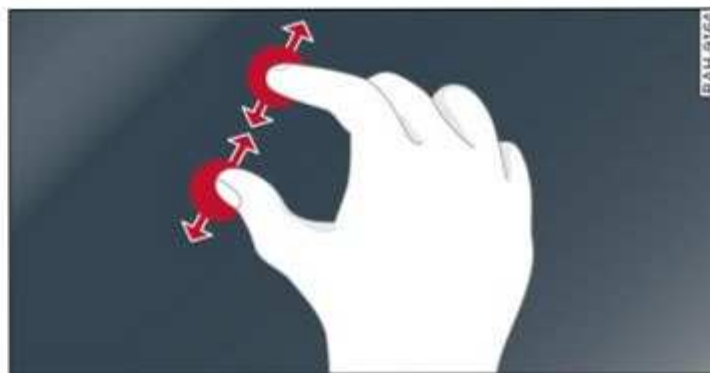

Fig. 11 Touch display: pinching fingers together and pulling them apart

Zooming in and out on an item

- ▶ To increase the size of an item, touch it with two fingers and pull your fingers apart.
- ▶ To decrease the size of an item, touch it with two fingers and pull your fingers together.

Rotating

Applies to: touch display



Fig. 12 Touch display: rotating

Rotating the view or perspective

- ▶ Rotate the item using two fingers.

Dragging

Applies to: touch display

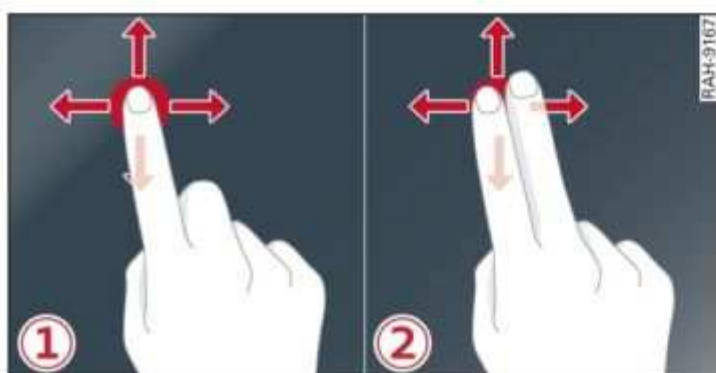

Fig. 13 Touch display: ① dragging with one finger, ② dragging with two fingers

Scrolling or browsing through menus/lists

- ▶ To scroll through menus and lists, swipe upward or downward with one finger.
- ▶ To browse through menus and lists, swipe to the right or left with one finger.

Tilting 3D displays

- ▶ Drag upward or downward with two fingers.

Dragging away from/toward the edge of the screen

Applies to: touch display



Fig. 14 Touch display: dragging away from the edge of the screen

Opening hidden menus

The  symbol indicates that there is a hidden menu.

- ▶ Use your finger to drag inward from the upper or lower edge of the screen, or
- ▶ Press the  button.

Closing hidden menus

- ▶ Press within the menu and drag it toward the upper or lower edge of the screen.

Information about menu paths

This guide shows you at a glance the paths for opening a desired menu and its settings and functions.

Example of a path

- ▶ Applies to: MMI: Select on the home screen: **SETTINGS** > **General** > **Date & time**.

Following the path

- ▶ First, determine in which display the path should be entered. In this example, it is the MMI display.
- ▶ To open the home screen, press .
- ▶ If the **SETTINGS** button is not displayed, use your finger to swipe to the left or right until it appears.
- ▶ Press the **SETTINGS** button.
- ▶ If the **General** button is not displayed, swipe toward the left or right with one finger until it appears.

- ▶ Press the **General** button.
- ▶ If the **Date & time** button is not displayed, swipe upward or downward with one finger until it appears.
- ▶ Press the **Date & time** button.

Tips

If a menu or symbol is in parentheses in the path, for example, (**General**) or () , then it is an optional menu item that does not need to be used in every system.

Settings

- ▶ Applies to MMI: Select on the home screen: **SETTINGS > Display & Brightness > MMI**.

Possible settings:

- **Brightness**
- **Touchscreen feedback**

Multi Media Interface

Traffic safety information

Audi recommends only using certain Infotainment system functions, such as entering a destination or pairing a mobile device, while the vehicle is stationary. Be prepared to stop operating the Infotainment system at any time in the interest of your safety and the safety of other road users.

WARNING



- Only use the Infotainment system when road, traffic, weather, and visibility conditions permit and always in a way that allows you to maintain complete control over your vehicle.
- This also applies to operating your mobile device via the MMI. Do not allow the visual or audio signals from a mobile device to distract you from traffic, because this increases the risk of an accident.

Tips

Certain functions are not available while driving.

Switching on or off

Switching the MMI on or off

- ▶ To switch the MMI off, press and hold  on the MMI control pad ⇒ *page 30, fig. 22* until all Infotainment functions are switched off.
- ▶ To switch the MMI on, press  on the MMI control pad.

Restarting the MMI

- ▶ Press and hold  on the MMI control pad for at least 10 seconds.

Switching the center display on or off

- ▶ To switch the center display off, press  in the notification center ⇒ *page 23*.
- ▶ To switch on the center display, touch the display.

Introduction

You can display and operate Infotainment system and vehicle functions using the touch display in the Multi Media Interface, abbreviated MMI.

Configuration wizard

After starting for the first time, the configuration wizard helps you to set up the vehicle, for example to set the desired system language and connect a telephone.

- ▶ Follow the instructions in the center display.
- ▶ Applies to: MMI: To access the configuration wizard at a later time, select on the home screen: **HELP > Configuration wizard**.

Tool tips

You can have tool tips displayed if necessary. They introduce various MMI functions to you.

- ▶ Applies to: MMI: To open the tool tips, select on the home screen: **HELP > Tool tips > Basic information** or **Expert information**.
- ▶ Follow the instructions in the display.

Online Owner's Manual

Applies to: vehicles with Online Owner's Manual

The Online Owner's Manual can be accessed directly from the Owner's Manual in the Infotainment system ⇒ *page 6*.

- Applies to: MMI: Select on the home screen:
HELP > Owner's manual.

Menus and symbols



Fig. 15 MMI: center display

	Label	Description
①	Overview screen	Displays selected information tiles and provides quick access to certain functions ⇒ <i>page 21</i>
②	Quick access bar	Return to the home screen or the overview page, open menus quickly ⇒ <i>page 22</i>
③	Display area	Select a menu, apply settings, display content ⇒ <i>page 22</i>
④ – ⑥	Status bar	Operate functions and apply quick settings ⇒ <i>page 23</i> , display of available notifications ⑤ ⇒ <i>page 23</i> , status indicator ⑥ ⇒ <i>page 23</i> , time

Description of common symbols

You can operate the default functions using the symbols that follow. The symbols may be found in any menu, depending on the context.

Symbol	Description
↶	Go back one level
✕	Close the menu
🔍	Search for content
ⓘ	Open explanations for a menu
⚙️	Open settings for the selected menu
🗄️	Open the submenu
📝/✍️	Adjust the settings
☆/★	Set as favorite
☐/☑️	Switch functions on or off

Symbol	Description
⏻/⏮	Switch functions on or off
⏪/⏩	Switch functions on or off
⋮	Open additional actions
>	Open additional information for the selected menu

Overview screen

The overview screen is the first menu page in the MMI. Information about certain vehicle functions such as media, time, and phone is displayed in tiles. The available information tiles can be rearranged on the overview screen or replaced with others. Depending on the system context, you may be able to operate certain functions directly, such as muting the sound. ►

Switching between the overview screen and the home screen

- ▶ Press  repeatedly until the desired view appears.

Configuring the overview screen

- ▶ Press and hold an information tile on the overview screen.
- ▶ To change the position of an information tile, press and hold it and then slide it to the desired position.
- ▶ To replace an information tile, press  and select the desired information tile.
- ▶ Press **Done** to complete the configuration.

Quick access

With quick access, you can return to the home screen and quickly switch between four menus that can be configured according to your preferences.

Returning to the home screen or opening a menu quickly

- ▶ Press  or one of the four buttons.

Configuring quick access

- ▶ Press and hold a button on the home screen display area or in the quick access bar.
- ▶ To move a button to the quick access bar, pull it from the display area to the quick access bar.
- ▶ To adjust the placement of the buttons in the quick access bar, pull them to the desired position in the bar.
- ▶ Press **Done** to complete the configuration.

Tips

The position of  cannot be adjusted.

Display area

You can freely change the location of the buttons on the home screen display area.

Configuring the display area

- ▶ Press and hold a button on the home screen display area.

- ▶ To adjust the placement of the buttons, pull them to the desired locations.
- ▶ Press **Done** to complete the configuration.

Switching between menu pages



If a menu contains multiple menu pages,  is displayed in the display area. The white bar shows the location of the current menu page.

- ▶ To switch between menu pages, swipe your finger to the right or left.

Favorites

By creating favorites, you can have quick access to various items, such as radio stations, frequently-used contacts, or vehicle settings. In the **FAVORITES** menu, the stored favorites are sorted by topic into information tiles.

Adding a favorite

A  button indicates if you can add a favorite, such as a selected radio station. Depending on the context, you may also be able to add items without the  button to the favorites, such as entries in a list.

- ▶ Press , or
- ▶ Press and hold an item in a list.
- ▶ Press **Store as favorite**. The selected item will be added as a favorite.

Using favorites

- ▶ Applies to: MMI: Select on the home screen: **FAVORITES**. The stored favorites will be displayed.
- ▶ To access a stored favorite, press that favorite.

Stored favorites can only be deleted or configured in the corresponding menu (such as **RADIO**).

Arranging information tiles

- ▶ Applies to: MMI: Select on the home screen: **FAVORITES**.
- ▶ Press and hold the desired information tile.
- ▶ Pull the information tile into the desired position.
- ▶ Press **Done** to confirm the configuration.

Status display



Fig. 16 Center display: frequently used symbols in the status bar

The symbols in the status bar show you information at a glance, such as if a mobile device is connected or if there is a data connection. The most common symbols are listed in the table.

	Description
①	There is a data connection. The bar indicates the signal strength of the data connection. Data is being transmitted now.
②	There is a data connection. The bar indicates the signal strength of the data connection. No data is being transmitted now.
③	A mobile device is connected. The bar indicates the signal strength of the cell phone connection.
④	There is no data connection.
⑤	An error occurred with the mobile device connection to the MMI.
⑥	A user is selected. If a question mark appears in the symbol  , the guest user is active.
⑦	A Bluetooth device is connected.
⑧	Bluetooth is switched on, but no Bluetooth device is connected.
⑨	Audio playback was interrupted.
⑩	The audio source is muted.
⑪	Privacy settings are enabled. The additional symbol indicates which privacy settings are currently activated ⇒ page 283.

Notification center



Fig. 17 Center display: notification center

Notifications can be displayed in the center display. They will be hidden after a certain period of time and a symbol for them will appear in the status bar ⑥ ⇒ page 21, fig. 15. In the notification center, you can view these notifications ③ ⇒ fig. 17, apply quick settings ②, and operate functions ①.

Using the notification center

- ▶ To open the notification center, pull the status bar downward, or
- ▶ Press the  button on the status bar.
- ▶ To turn quick settings on or off, press the respective symbol ①.
- ▶ To apply quick settings, press the respective symbol ②.
- ▶ To obtain additional information about a notification, press it.
- ▶ To delete a notification, pull it toward the right edge of the screen.
- ▶ If there are more than four notifications in the notification center, the older notifications will be hidden. To display the older notifications, drag your finger upward on the screen.

Setting which content is displayed

You can set whether some notifications should be displayed.

- ▶ To set the displayed content, press , or
- ▶ Applies to MMI: Select on the home screen: **SETTINGS > Notifications.**
- ▶ Select and confirm which notifications should be displayed.

Operating functions

Depending on the vehicle equipment, the following functions can be operated in area ①: ▶

Symbol	Description
	Press: switches the center display on or off
	Press and hold: switches screen clearing mode on or off
	Opens the garage door opener function
	Press: shows settings for the head-up display
	Press and hold: switches the head-up display on or off

Applying quick settings

Depending on vehicle equipment, the following quick settings may be available in area ②:

Symbol	Description
	Apply sound settings
	Manage connected devices
	Manage users
	Set displayed content in the notification center
3:50 PM 24/6/2019	Set date and time

Text input

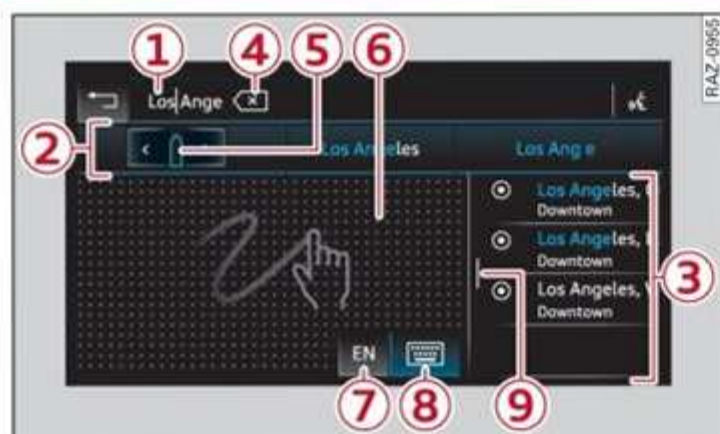

Fig. 18 Center display: text input

Overview

In the input fields of various menus, you can enter letters, numbers and characters, for example to find an address in navigation*.

The text that is currently entered is displayed in the center display ①. Depending on the context, word suggestions may be given based on the characters that have been entered ② and results may be shown ③.

Opening text input

- ▶ Tap inside the input field ①.

Switching input languages

Requirement: multiple input languages must be defined in the MMI ⇒ page 25.

- ▶ To switch between the defined input languages, press the button ⑦.



Switching the input methods

- ▶ To switch between handwriting input or the on-screen keyboard, press the button ⑧.

Entering text

- ▶ Applies to: the on-screen keyboard: To enter text, press the buttons on the keyboard. Depending on the usage context, you may also be able to swipe over the letters ¹⁾.
- ▶ Applies to: handwriting input: To enter text, simply write in the input area using one finger ⑥. You can write the separate characters next to each other or one on top of the other without having to move your finger over after writing a character. When you end the entry, the writing is interpreted by the system.
- ▶ Applies to: the on-screen keyboard with an input language that uses accented characters: To enter accented characters (such as â, ç, ñ, ö), press and hold a character that has accented versions available and select the desired accented character.
- ▶ Applies to: handwriting input: To enter a space, drag a line from left to right in the input section ⑥.
- ▶ To select a location in the text input, press on the desired location in the input field. You can control the location more accurately using the slider on the screen ⑤¹⁾.
- ▶ To delete individual characters, press ④, or ▶

¹⁾ Depending on the country or equipment

- ▶ Applies to: handwriting input: Drag a line from right to left in the input section ⑥.
- ▶ To delete multiple characters, press and hold  ④.
- ▶ To delete all characters at a specific location, press and hold  ④ and drag up to the desired location ¹⁾. When released, the highlighted characters are deleted.

Accepting suggested words or selecting entries from the results list

- ▶ To accept a suggested word ② or select an entry from the results list ③, press on it.
- ▶ To display more content in the results list, drag your finger upward or downward on the screen.
- ▶ To enlarge the results list, press the ⑨ button or pull it inward.

Setting the input language or keyboard layout

- ▶ Select on the home screen: **SETTINGS > Language & keyboard > Keyboard.**
- ▶ To define additional input languages, press the  button.
- ▶ To change the keyboard layout for an input language, press >. For example, you can select between QWERTZ and QWERTY.

¹⁾ Depending on the country or equipment

Head-up display

Description

Applies to: vehicles with head-up display



Fig. 19 Windshield: display areas of the head-up display

The augmented reality head-up display has a static display area ① and an augmented reality display area ②. Certain information can be displayed in the static area, for example speed and indicator lights. In the augmented reality display area, content such as displays about navigation and assist systems may be integrated directly into the driver's view outside the vehicle, depending on the situation.

Switching on and off

The  button is located in the notification center in the MMI ⇒ *page 23*.

- ▶ To switch the head-up display on or off, press and hold the  button.

After switching the head-up display on, it can take several seconds before information is shown in the display.

Settings in the Infotainment system

- ▶ Applies to: MMI: Select on the home screen: **SETTINGS > Display & Brightness > Head-up display**.

Possible settings:

- **Display rotation**
- **Brightness**
- **Display:** you can turn off the head-up display or specify which display areas are shown.
- **Display height:** you can adjust the height of the display. Sit in the correct seating position ⇒ *page 60* and adjust the head-up display.

- **Display contents:** you can set which information should be displayed. Some information and warnings cannot be hidden.

Note

To reduce the risk of scratches on the glass covering the head-up display, do not place any objects in the projection opening.

Tips

- Sunglasses with polarization filters and unfavorable lighting conditions can impair visibility of the display.
- An optimal display depends on the seat position and the height adjustment of the head-up display.
- A special windshield is needed for the head-up display function.
- For information on cleaning, see ⇒ *table Interior cleaning on page 264*.

Voice recognition system

General information

Applies to: vehicles with voice recognition system

You can operate many functions in the vehicle easily using voice commands.

Using the voice recognition system optimally

- ▶ Speak clearly and distinctly at a normal volume. Speak louder when driving faster.
- ▶ Emphasize the words in the commands evenly and do not leave long pauses.
- ▶ To reduce background noise, close all openings, such as doors and windows. Make sure that passengers are not speaking when you are giving a voice command.
- ▶ Do not direct the vents toward the hands-free microphone, which is in the roof headliner near the front interior lights.
- ▶ Only use the system while seated in the driver's seat. All handsfree microphones are oriented for this seat position.

WARNING

- Direct your full attention to driving. As the driver, you have complete responsibility for safety in traffic. Only use the functions in such a way that you always maintain complete control over your vehicle in all traffic situations.
- Do not use the voice recognition system in emergencies because your voice may change in stressful situations. The system may take longer to dial the number or may not be able to dial it at all. Dial the emergency number manually.

Tips

There are no voice guidance* prompts when a dialog is active.

Description

Operating the voice recognition system



Applies to: vehicles with voice recognition system



Fig. 20 Center display: voice recognition system

Requirement: the ignition and the MMI must be switched on. A system language supported by the voice recognition system must be set. There must be no phone calls in progress and the parking aid must not be active.

Operating by button

- ▶ Briefly press the  button on the multifunction steering wheel, or depending on the context, press  in the center display.
- ▶ Say the desired command after the signal tone.
- ▶ To switch the voice recognition system off, press and hold the  button on the multifunction steering wheel, or say or press **Cancel** ① ⇒ *fig. 20*.

Operating with voice commands

- ▶ Applies to: MMI: To operate the voice recognition system using voice commands, select on the home screen: **SETTINGS > General > (Speech dialog system) > Activate the speech dialog system with "Hey Audi"**.
- ▶ Say the activation phrase **Hey Audi** together with the desired command.
- ▶ To switch the voice recognition system off, say **Cancel** or press and hold the  button on the multifunction steering wheel, or press ① ⇒ *fig. 20*.

Commands and assistance

In the voice recognition system menu, possible commands or help settings are displayed for the current dialog ③.

- ▶ To receive additional help for the current dialog, say or press **Help** ②.

- ▶ To pause voice recognition, say or press **Pause** ④. To reactivate voice recognition, press ④ again or briefly press the  button on the multifunction steering wheel.

Additional functions

Applies to: vehicles with voice recognition system

Command during voice output

If the function is switched on, you can simply say a new command during a prompt.

- ▶ Applies to: MMI: Select on the home screen: **SETTINGS > General > Speech dialog system > Allow commands during voice output.**

Online recognizer

Applies to: vehicles with online recognizer

You can activate the online recognizer for additional functions and to improve the results of voice recognition. A supported menu language must be selected. When there is an active Internet connection, the spoken command is evaluated in the vehicle and online.

- ▶ When you switch on the voice recognition system for the first time, a menu for the online recognizer will open, or
- ▶ Applies to MMI: Select on the home screen: **SETTINGS > General > Speech dialog system > Consent to online speech recognizer.**
- ▶ Read the licensing agreements and accept them.

Amazon Alexa

Applies to: vehicles with Amazon Alexa Integration

You can activate Amazon Alexa to access certain functions. A reduced number of commands for Amazon Alexa are available during this.



Requirement: you must be logged in to your myAudi account in the vehicle. The online recognizer must be activated. A system language that is supported by both the voice recognition system and Amazon Alexa must be selected.

- ▶ Applies to: MMI: Select on the home screen: **USERS > Connect to Amazon Alexa.**
- ▶ Follow the instructions in the display.
- ▶ Applies to: MMI: To operate Amazon Alexa using voice commands, select on the home

screen: **SETTINGS > General > (Speech dialog system) > Activate the speech dialog system with "Hey Audi".**

- ▶ Say the activation phrase "Alexa" together with the desired command.

Note

Read the information about Audi connect, and be sure to note the connectivity costs section   in *General information on page 185.*

Tips

Audi provides access to services from third party providers. Permanent availability cannot be guaranteed, because that depends on the third party provider.



External voice operation

Applies to: vehicles with external speech dialog system

You can access and control the voice operation on a connected mobile device through your vehicle.

Switching external voice operation on or off

Requirement: the ignition and the MMI must be switched on. A cell phone must be connected to the MMI with the **Handsfree** profile  *page 174.* The mobile device being connected must have voice control that can be controlled externally. There must be no phone calls in progress and the parking aid must not be active.

- ▶ To switch on the external voice operation, press and hold the  button longer on the multifunction steering wheel.
- ▶ To switch off the external voice operation, press and hold the  button longer on the multifunction steering wheel or press **Cancel**.

Using external voice operation

- ▶ Say the desired command after the signal tone.
- ▶ To reactivate voice recognition when it is paused, press the  button briefly on the multifunction steering wheel or press **Resume**.

Tips

Audi simply provides access to control your cell phone with voice operation and does not

take any responsibility for the contents and commands within the external voice control.

Global functions

Additional function buttons

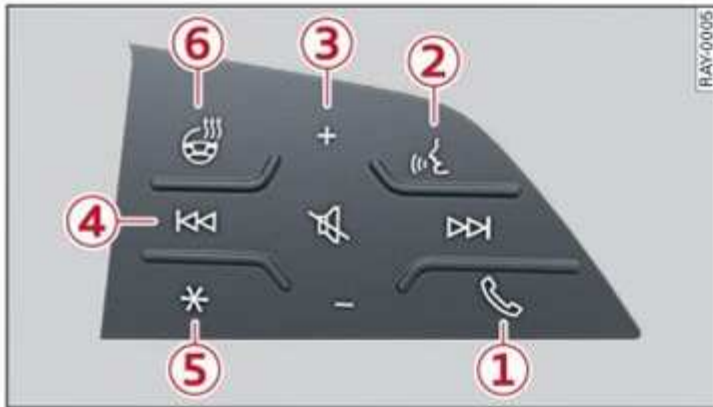

Fig. 21 Right side of the multifunction steering wheel



Fig. 22 Center console: MMI control pad

Adjusting the volume

You can adjust the volume of an audio source or a system message (for example, from the voice recognition system) when the sound is playing.

- ▶ To increase or decrease the volume using the steering wheel controls, press the +/- button (3), or to control using gestures, swipe your finger up or down in area (3), or
- ▶ To increase or decrease the volume using the MMI control pad ⇒ fig. 22, swipe your finger clockwise or counterclockwise.
- ▶ To mute, press on the steering wheel or on the MMI control pad.

Selecting the previous/next track or station

- ▶ Press the button (4) on the steering wheel, or to control using gestures, swipe your finger to the left or right in area (4), or
- ▶ Press on the MMI control pad.

Fast forward/rewind

- ▶ Press and hold on the steering wheel (4) or on the MMI control pad until the desired playback position is reached.

Quick access steering wheel button

Depending on vehicle equipment, the button (5) may provide quick access to various functions.

You can program the * button with various functions.

- ▶ To bring up the function that is currently set, press the * button.
- ▶ To perform the function that is currently set, press and hold the * button, or:
- ▶ Applies to MMI: Select on the home screen: **VEHICLE > Settings & Service > Steering wheel button asgmt.**
- ▶ Select and confirm the desired function.

Turning the steering wheel heating on or off

Applies to: vehicles with steering wheel heating

button (6), see ⇒ page 87.

Switching the voice recognition system on or off

button (2), see ⇒ page 27.

Using the telephone functions

button (1), see ⇒ page 180.

WARNING

Adjust the volume of the audio system so that signals from outside the vehicle, such as police and fire sirens, can be heard easily at all times.

Personalization

Users

General information

Applies to: vehicles with personalized user settings

Depending on vehicle equipment and your country, your vehicle may be able to manage various users in the MMI. Each user will be assigned the settings that they last used.

Before you begin driving, you can select a user in the MMI and load personalized Infotainment and vehicle settings.

Possible users in the MMI:

- **myAudi user:** as a myAudi user, you can use Audi connect services that require a myAudi account. Certain settings are transferred online to your myAudi account. If you log into your myAudi account in another vehicle, you can load your settings in the other vehicle.
- **Local user:** as a local user, you can only store settings in the current vehicle. Your settings cannot be transferred to other vehicles. Audi connect services that can only be used with a myAudi account will not be available.
- **Guest user:** as a guest user, you can store settings in the vehicle without changing the settings for other users. Audi recommends only using the guest user temporarily, because settings can be overwritten by other users.



WARNING

It may not be possible to load Infotainment and vehicle settings, or they may only load partially. To reduce the risk of an accident, the driver must be responsible for the Infotainment system settings and vehicle settings at all times.



Tips

- Certain Infotainment and vehicle settings (such as mirrors, last radio stations) may be stored, depending on vehicle equipment. You can find additional information in the MMI. Select on the home screen: **SETTINGS** > **General** > **Legal notes** > **About Audi connect**.

- Applies to: myAudi users: The stored settings can only be transferred to vehicles that are capable of receiving the transmitted information. There may be restrictions that prevent this, particularly in other countries.
- Applies to: myAudi users: The settings can only be transferred and loaded when there is coverage from the applicable mobile phone service provider.
- Applies to: myAudi users with PIN protection switched on: If the MMI displays a detected user but you simply start driving or wait without entering the 4-digit PIN, then the guest user will be selected. Some settings for the detected myAudi user will be transferred to the guest user.

User management

Applies to: vehicles with user management

Opening user management

Applies to: MMI

- ▶ Press **USERS** on the home screen.

Selecting a user

Applies to: MMI

- ▶ Press on the desired user.
- ▶ Enter the 4-digit myAudi PIN, if necessary.

Adding myAudi users

Applies to: MMI and Audi connect

Requirement: you must have successfully registered at my.audi.com and have created a 4-digit myAudi PIN.

- ▶ Press **Add user**.
- ▶ Press **Log in now** to log in with your myAudi credentials.
- ▶ Follow the system instructions.

To transfer existing destinations from the MMI to your myAudi account one time, confirm the system prompts with **Yes**.

Adding a local user

Applies to: MMI

- ▶ Press **Add user**.
- ▶ Press **Initiate setup**.
- ▶ Press **Local user**.

- ▶ Follow the system instructions.

Editing users

Applies to: MMI

Requirement: the user must be selected and that user's settings must be loaded.

- ▶ Press on the user.

Depending on the user type, available options may include the following.

PIN protection: when this function is switched on, the 4-digit myAudi PIN must be entered before any settings for this user can be loaded.

Remove the user from the vehicle: the user will only be deleted in the vehicle from the list in the MMI.

Removing users

Applies to: MMI

- ▶ Select on the home screen: **Users** >  > *one or more entries* > **Delete**. The user will only be deleted from the list in the MMI. The authorizations for the user in the vehicle (such as key user) will not be removed.

Tips

- The guest user cannot be renamed.
- When changing users, the new user settings are loaded in the vehicle.
- If a user has the  symbol, PIN protection is active. To switch off PIN protection, you can edit the user.
- Depending on the country, you may be able to use an Audi app or my.audi.com.

Key user

Applies to: vehicles with key user management

The vehicle owner must be set as the key user to use some of the specific Audi connect vehicle control services that depend on vehicle equipment.

The key user automatically has remote access authorization. This remote access authorization is necessary to control certain functions that depend on the equipment, such as Audi connect vehicle control services, through the myAudi app.

Setting the key user

Requirement: a key user must not be set yet.

- ▶ To set a key user for the vehicle, you will need a myAudi account. Register in the myAudi app or at my.audi.com.
- ▶ Add your vehicle to the myAudi app.
- ▶ Follow the instructions in the myAudi app.

Removing the key user

If you remove the key user, all other users that were stored by the key user at my.audi.com and their authorizations will be deleted. It will no longer be possible to use the Audi connect vehicle control services, depending on the vehicle equipment.

Requirement: a key user must be set. The ignition has been switched on with a vehicle key.

- ▶ Applies to: MMI: Select on the home screen: **USERS** >  > **Remove key user**.

Tips

- Depending on the country and model there may be an app other than the "myAudi app" available for your vehicle. For additional information, see my.audi.com.
- You do not need to log into the vehicle with a myAudi user in order to use Audi connect vehicle control services, which depend on the vehicle equipment.
- If you sell your vehicle, reset all settings to the factory default settings.

Opening and closing

Central locking

General information

WARNING

- If you leave the vehicle, switch the ignition off and take the key with you. This applies particularly when children remain in the vehicle. Otherwise, children could start the vehicle or operate electrical equipment (such as power windows), which increases the risk of an accident.
- No one, especially children, should stay in the vehicle when it is locked from the outside, because the windows can no longer be opened from the inside. Locked doors make it more difficult for emergency workers to enter the vehicle, which puts lives at risk.
- Applies to: child safety lock: No one, especially children, should stay in the vehicle when the child safety lock is activated, because the rear doors and the windows can no longer be opened from the inside. This increases the risk of fatal injury.

Description

All doors and the luggage compartment lid can be centrally unlocked and locked at once. You can select in the MMI if the entire vehicle or only the driver's door should unlock when unlocking the vehicle ⇒ *page 34*. The turn signals flash twice when you unlock the vehicle and flash once when you lock the vehicle. If they do not flash when locking, check if all doors and lids are closed.

Depending on the vehicle equipment, you may have different options for centrally unlocking and locking your vehicle.

- Vehicle key ⇒ *page 38*
- Sensors in the door handles ⇒ *page 38*
- Lock cylinder in the driver's door ⇒ *page 35*
- Interior central locking switch ⇒ *page 35*

Vehicle key

The term “vehicle key” refers to the remote control key or convenience key*. The convenience

key* is a remote control key with special functions ⇒ *page 38* and ⇒ *page 90*.

Automatic locking

If you unlock the vehicle but then do not open any of the doors, the luggage compartment, or the hood within a short period time, the vehicle will lock again automatically. This feature prevents the vehicle from being accidentally left unlocked for a long period of time.

Automatic locking (Auto Lock)

The Auto Lock function locks all doors and the luggage compartment lid once the speed has exceeded approximately 9 mph (15 km/h). The vehicle will unlock again if the unlock function in the central locking switch is pressed, the parking brake is set, or the ignition is switched off.



You can open the doors individually from the inside by pulling the door handle one time. To open the rear doors individually, you must pull the door handle twice.

In the event of a crash with airbag deployment, the doors will also automatically unlock to allow access to the vehicle.

Unintentionally locking yourself out

Only lock your vehicle when all of the doors and the luggage compartment lid are closed and there is no key in the vehicle. This reduces the risk of locking yourself out accidentally.

The following features help to reduce the risk of locking your vehicle key in the vehicle:

- If the driver's door is open, the vehicle cannot be locked by pressing the  button on the remote control key or by touching the locking sensor* on a door.
- Applies to: vehicles with convenience key: If the vehicle key that was last used is located in the luggage compartment, then the luggage compartment lid will be temporarily unlocked so that you can retrieve the keys ⇒ .
- Applies to: vehicles with convenience key: If the vehicle key that was last used is detected inside the vehicle, then it will not be possible to lock the vehicle from the outside ⇒  ▶

WARNING

Observe the safety precautions ⇨ *page 33*.

Note

Applies to: vehicles with convenience key

The following applies when locking the vehicle:

- If the vehicle key that was last used is detected inside the passenger compartment, then the vehicle cannot be locked from the outside **using the sensor**. Take the vehicle key with you and lock the vehicle again. Otherwise, the vehicle will not be protected against unauthorized access.
- If you locked the vehicle while the front passenger's door or rear door is open, and you accidentally place the vehicle key inside the passenger compartment and close the door, the vehicle will lock at first. But if the keyless system detects a vehicle key inside the vehicle after it locks, then the vehicle will unlock again. The turn signals will flash several times and a warning tone¹⁾ will sound to indicate this. If you do not open the vehicle to remove the vehicle key within a brief period, then the vehicle will lock automatically. This prevents the vehicle from being left unlocked for long periods of time. The vehicle key will then be locked inside the vehicle.
- If you locked the vehicle while the luggage compartment lid is open, and you accidentally place the vehicle key inside the luggage compartment and close the luggage compartment lid, the vehicle will lock at first. But if the keyless system detects a vehicle key inside the luggage compartment after it locks, then the luggage compartment will be unlocked again. The turn signals will flash several times and a warning tone¹⁾ will sound to indicate this. If you do not open the luggage compartment lid to remove the vehicle key within a brief period, then the luggage compartment will lock au-

tomatically. This prevents the vehicle from being left unlocked for long periods of time. The vehicle key will then be locked inside the luggage compartment.

Tips

- Do not leave valuables unattended in the vehicle. A locked vehicle is not a safe!
- The LED in the driver's door rail blinks when you lock the vehicle. If the LED turns on for approximately 30 seconds after locking, there is a malfunction in the central locking system. Have the problem corrected by an authorized Audi dealer or authorized Audi Service Facility.

Setting the central locking system

You can adjust the central locking system to your preferences. The settings depend on the vehicle equipment.

- ▶ Applies to MMI: Select on the home screen: **VEHICLE > Settings & Service > Central locking**.

Door unlocking

- If you select **All**, all doors and the luggage compartment lid will be unlocked when unlocking the vehicle.
- If you select **Driver's door**, only the driver's door will be unlocked. To unlock all doors and the luggage compartment lid, press the  button on the vehicle key twice. In vehicles with a convenience key*, only the driver's door will unlock when you pull the driver's door handle. If you pull another door handle, the entire vehicle will be unlocked.

The entire vehicle will always be locked if you press the  button.

Long press to open windows

You can select if all windows and the panoramic glass roof* should open using the vehicle key ⇨ *page 44, Convenience opening and closing*. ▶

¹⁾ Applies to: vehicles with anti-theft alarm system

Tone when locking¹⁾

You can select if an audio signal sounds when locking the vehicle.

Applies to: vehicles without anti-theft alarm: The audio signal will only sound if you locked twice within a short period of time.

Open with convenience key

Applies to: vehicles with convenience key

You can deactivate the feature for unlocking using the sensor. The function for locking via the sensor will still be enabled ⇒ page 38.

Central locking switch



Fig. 23 Driver's door: central locking switch

- ▶ To lock or unlock the vehicle, press the or button ⇒ .

When locking the vehicle with the central locking switch, the following applies:

- The doors and the luggage compartment lid cannot be opened from the outside for security reasons, for example, to reduce the risk of unauthorized entry while stopped at a light.
- The LED in the central locking switch turns on when all doors are closed and locked.
- You can open the doors individually from the inside by pulling the door handle one time. To open the rear doors individually, you must pull the door handle twice.
- In the event of a crash with airbag deployment, the doors unlock automatically to allow access to the vehicle.

WARNING

- Observe the safety precautions ⇒ page 33.
- The central locking button works when the ignition is switched off.
- The central locking switch is inoperative when the vehicle is locked from the outside.

Messages

The following messages may appear depending on the vehicle equipment:

Driver's door: malfunction! Shift to P before leaving vehicle. See owner's manual

There is a malfunction in the driver's door. Before exiting, set the parking brake to secure the vehicle. Drive immediately to an authorized Audi dealer or authorized Audi Service Facility to have the malfunction repaired.

Mechanically unlocking and locking the doors

All doors must be unlocked or locked separately if the central locking system fails.

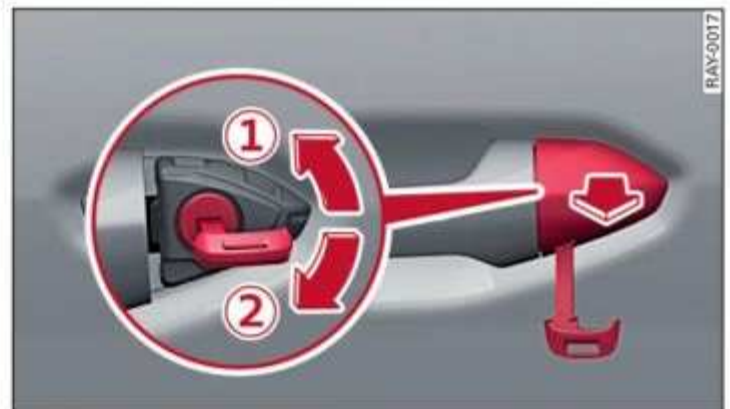



Fig. 24 Driver's door: door lock cylinder





Fig. 25 Door: mechanically locking

¹⁾ This function is not available in all countries.

Applies to: vehicles with anti-theft alarm system:
After unlocking using the lock cylinder and opening the driver's door, you must press the  button on the vehicle key or switch the ignition on. Otherwise the alarm will sound. When mechanically locking the doors, the anti-theft alarm will not be activated.

Unlocking or locking the driver's door with the mechanical key

- ▶ Remove the mechanical key ⇒ *page 37*.
- ▶ Insert the mechanical key into the slot under the door handle and pry the cap off ⇒ *fig. 24*.
- ▶ To unlock the driver's door, turn the mechanical key to the unlock position in the direction of arrow  ⇒ *fig. 24*.
- ▶ Pull the door handle to open the driver's door.
- ▶ To lock the driver's door, set the parking brake, close the door, and turn the mechanical key once to the lock position  ⇒ .

Locking the front passenger's door and rear doors using the mechanical key

The mechanical lock is located on the edge of the doors. It is only visible when the door is open.

- ▶ Remove the mechanical key ⇒ *page 37*.
- ▶ If necessary, remove the cap from the opening ⇒ *fig. 25*.
- ▶ Insert the mechanical key into the slot on the inside and turn it all the way to the right (right door) or left (left door).
- ▶ If necessary, install the cap in the opening and close the door.

Once the front passenger's door or rear doors close, it will no longer be possible to open them from the outside. The front doors can be opened from the inside by pulling the door handle one time. The rear doors can be unlocked from the inside by pulling the door handle one time and then opened by pulling the door handle again. If the child safety lock in one of the rear doors is activated, you must first pull the door handle from the inside. Then you can open the door from the outside.

Anti-theft alarm system

Applies to: vehicles with anti-theft alarm system

If the anti-theft alarm system detects a vehicle break-in, audio and visual warning signals are triggered. The anti-theft alarm system is switched on or off when locking or unlocking your vehicle. If the alarm is triggered, it will shut off automatically after a certain amount of time.

Switching the alarm off manually

- ▶ To switch the alarm off, press the  button on the vehicle key or switch the ignition on.

Depending on the vehicle equipment, the anti-theft alarm system may have the following features:

Break-in security feature

The alarm will be triggered if the doors, the front compartment lid, or the luggage compartment lid are broken into, or if a door that was previously unlocked using the lock cylinder is opened.

Interior/towing protection monitor

The alarm will be triggered if there are movements detected in the vehicle interior (for example, by animals) or if there is a change in the vehicle angle (for example, when the vehicle is being towed).

You can prevent the alarm from being triggered by deactivating the interior/towing protection monitor.

Deactivating the interior/towing protection monitor

There are the following options for deactivating the interior/towing protection monitor:

- ▶ Press the  button on the vehicle key a second time **within two seconds**. Or
- ▶ Applies to: vehicles with convenience key:
Touch the sensor on the door handle a second time **within two seconds**. Or
- ▶ Turn the mechanical key in the door lock to the close position a second time **within two seconds**. Or
- ▶ Applies to: vehicles with MMI: Select on the home screen: **VEHICLE > Settings & Service > Interior monitoring**.

WARNING

Observe the safety precautions ⇒ *page 33*.

If you lock the vehicle, then the interior/towing protection monitor will stay off until the next time the vehicle is unlocked.

i Tips

The interior/towing protection monitor only functions correctly when the windows and the panoramic glass roof are closed.

Keys

Key set



Fig. 26 Your vehicle key set

The key set includes two vehicle keys when delivered from the factory.

① Vehicle key

You can unlock and lock your vehicle with the vehicle key.

② Mechanical key and release button for mechanical key

A mechanical key is integrated in the vehicle key. To remove it, press the release button and remove the mechanical key.

Using the mechanical key, you can:

- Applies to: vehicles with lockable glove compartment: locking/unlocking the glove compartment.
- Manually unlock and lock the doors ⇒ *page 35*.

③ PANIC button

In an emergency, you can press the PANIC button to trigger a visible and audible vehicle alarm. You can do this as long as you are near your vehicle (within the range for the remote control key).

- To trigger the alarm, press the **PANIC** button ③ ⇒ *fig. 26*.
- To turn the alarm off, press the **PANIC** button again.

Lost key/replacing a key

If a vehicle key is lost, contact an authorized Audi dealer or authorized Audi Service Facility. Have this vehicle key deactivated. It is important to bring all keys with you.

If a key is lost, you should report it to your insurance company.

Electronic immobilizer

The immobilizer prevents unauthorized use of the vehicle.

In some cases, it may not be possible to establish vehicle drive ready mode if there is also a vehicle key from a different vehicle manufacturer on the key chain.

! WARNING

Observe the safety precautions ⇒ *page 33*.

! Note

Protect the key against high temperatures and direct sunlight.

♻️ For the sake of the environment

♻️ Batteries and electrical/electronic devices must be disposed of in an environmentally safe manner ⇒ *page 291, Disposal instructions*.

i Tips

- The vehicle key function can be temporarily disrupted by interference from transmitters near the vehicle working in the same frequency range (such as a mobile device or radio equipment). Always check if your vehicle is locked.
- Applies to MMI: You can view the number of keys programmed to the vehicle by selecting on the home screen: **VEHICLE > Settings & Service > Vehicle information**.
- A key tag that contains information about the vehicle key set may be attached to the

key set at the factory. The key tag can be used to reorder vehicle keys. Keep the key tag. If you sell the vehicle, give the key tag to the buyer.

- The system complies with United States FCC regulations and ISED regulations
⇒ *page 291*.

Unlocking and locking the vehicle

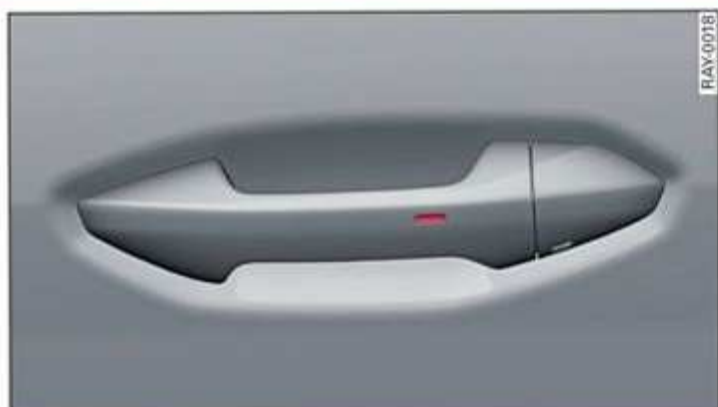

Applies to: vehicles with convenience key
Fig. 27 Door handle: sensor* for locking the vehicle

Depending on the vehicle equipment, you may have various options for unlocking and locking your vehicle. The settings in the MMI specify which doors will unlock ⇒ *page 34*.

Unlocking or locking using the vehicle key buttons

- ▶ To unlock the vehicle, press the button
⇒ *page 37, fig. 26*.
- ▶ To lock the vehicle, press the button **once**.

Unlocking or locking using the sensors

Applies to: vehicles with convenience key

- ▶ To unlock a door or the luggage compartment lid, grasp the door handle or luggage compartment lid handle.
- ▶ To lock the vehicle, close the door and touch the sensor on the door handle **once** ⇒ *fig. 27*. Do not grasp the door handle while locking the vehicle, or else the vehicle will not lock. The door cannot be opened for a brief period directly after locking it. This way you have the opportunity to check if the doors locked correctly.

WARNING

Observe the safety precautions ⇒ *page 33*.

Tips

- Only use the vehicle key when you can see the vehicle.
- The vehicle can only be locked when the parking brake is set.
- Do not use the vehicle key to lock and unlock when you are inside the vehicle. Otherwise, you could trigger the anti-theft alarm*. If this happens, press the unlock button.
- The exterior mirrors will automatically fold in or out when locking or unlocking the vehicle.

Tips

Applies to: vehicles with convenience key

- When unlocking or locking the vehicle, the convenience key cannot be more than approximately 4 feet (1.5 m) away from the door handle or luggage compartment.
- Unlocking with the convenience key (keyless access) can be deactivated in the MMI system ⇒ *page 34*.
- To prevent the vehicle battery from discharging, the energy management gradually switches off convenience functions that are not needed. You then may no longer be able to unlock your vehicle with the sensors.

LED and battery in the vehicle key



Fig. 28 Vehicle key: removing the battery cover

LED in the vehicle key

The LED indicates the vehicle key function.

- ▶ If you press a button briefly, the LED blinks once.

- ▶ If you press and hold a button (convenience opening/closing), the LED blinks several times.
- ▶ If the LED does not blink, the vehicle key battery is drained. Replace the battery in the vehicle key.

Replacing the vehicle key battery

The replacement battery in the remote control key must meet the same specifications as the original battery (battery type **CR 2032**).

- ▶ Remove the mechanical key ⇒ *page 37* and insert it at an angle into the opening ⇒ *fig. 28* of the remote control key.
- ▶ To remove the battery cover, press in the mechanical key inside the remote control key so far in the direction of the battery cover that the cover slightly lifts up ② ⇒ *fig. 28*. Then lift off the battery cover from the outside.
- ▶ Replace the battery and insert the new battery with the “+” symbol facing up.
- ▶ Install the battery cover.
- ▶ Reinsert the mechanical key.

If the  indicator light appears with a corresponding message, the vehicle key battery is drained and must be replaced.

WARNING

If batteries or coin cell batteries are swallowed or enter the body in any other way, they can cause serious or fatal injuries within a short period of time. There is a risk of chemical burns.

- Keep vehicle keys and key fobs with batteries out of the reach of children.
- Keep new or used batteries away from children.
- If the battery compartment on a vehicle key does not close securely, stop using the key and keep it away from children.
- Seek medical attention immediately if you suspect that a battery was swallowed or has entered the body in any other way.

For the sake of the environment

 Batteries and electrical/electronic devices must be disposed of in an environmentally

safe manner ⇒ *page 291, Disposal instructions*.

Luggage compartment lid

General information

WARNING

- No one, especially children, should stay in the vehicle when it is locked from the outside, because the windows can no longer be opened from the inside. Locked doors make it more difficult for emergency workers to enter the vehicle, which puts lives at risk.
- Always close and lock the luggage compartment lid and the doors when the vehicle is not in use. Otherwise someone such as a child could enter the vehicle through the luggage compartment and become locked inside it. To reduce the risk of injury, do not allow children to play in or around the vehicle.
- To reduce the risk of injuries by pinching, make sure that no one is in the operating area of the luggage compartment lid when closing, especially near the hinges, at the upper and lower edges of the lid, or all around the edge of the lid in general.
- After closing the luggage compartment lid, make sure that it is latched. The luggage compartment lid could open suddenly while driving, which would increase the risk of an accident.
- Never drive with the luggage compartment lid ajar or open, because poisonous gases from the surrounding area can enter the vehicle interior and increase the risk of asphyxiation.
- If there is a luggage rack (such as a bicycle rack) on the luggage compartment lid, the luggage compartment lid may not open completely under certain circumstances or it could close by itself if open due to the extra weight. Therefore, the open luggage compartment lid must be given additional support or the cargo must first be removed from the luggage rack.

– Applies to: vehicles with power-operated or sensor-controlled luggage compartment lid: Pay careful attention when closing the luggage compartment lid. Otherwise, you could cause serious injury to yourself or others despite the pinch protection.

Note

The luggage compartment lid can bump into objects such as the garage ceiling when opening and become damaged.

Tips

When the vehicle is locked, the luggage compartment lid can be unlocked separately by pressing the  button twice on the vehicle key. The luggage compartment lid locks automatically when it is closed again.

Opening and closing the luggage compartment lid





Fig. 29 Rear lid: handle



Applies to: vehicles with automatic luggage compartment lid:
Fig. 30 Driver's door: opening the luggage compartment lid

Opening the luggage compartment lid

- ▶ Applies to: vehicles without convenience key: Unlock the vehicle or the luggage compartment lid using the  /  button on the vehicle key and press the handle in the luggage compartment lid ⇒ *fig. 29*. Or
- ▶ Applies to: vehicles with convenience key: Press the handle in the luggage compartment lid ⇒ *fig. 29*. When the luggage compartment is locked, the vehicle key cannot be more than approximately 4 feet (1.5 m) away from the luggage compartment. Or
- ▶ Applies to: vehicles with automatic luggage compartment lid: Set the parking brake and pull the  button in the driver's door.

Closing the luggage compartment lid

- ▶ Applies to: vehicles without automatic luggage compartment lid: Use the inside handle to pull the luggage compartment lid down and allow it to drop gently to close it. Or
- ▶ Applies to: vehicles with automatic luggage compartment lid: Note ⇒ *page 40*.

WARNING

Observe the safety precautions ⇒ *page 39*.

Automatic luggage compartment lid

Applies to: vehicles with automatic luggage compartment lid

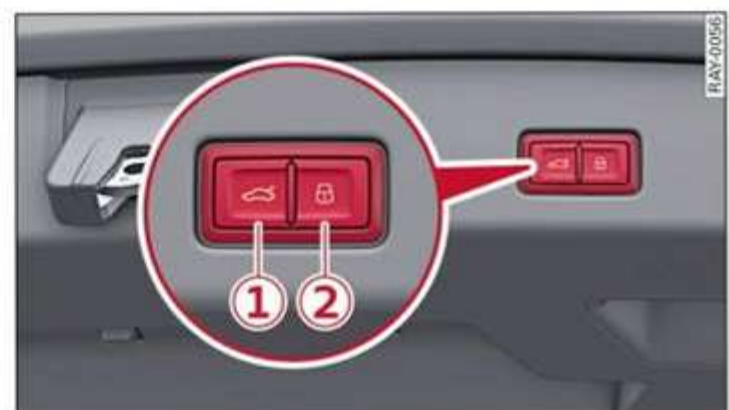











Fig. 31 Luggage compartment lid: ① closing button*, ② lock button* (vehicles with convenience key*)

The luggage compartment lid can be opened and closed automatically ⇒  in *General information on page 39*.

Opening the luggage compartment lid

- ▶ When the ignition is switched off, press the  button on the vehicle key twice ⇒ *page 37, fig. 26*. Or
- ▶ Set the parking brake and pull the  button in the driver's door. Or
- ▶ Applies to: vehicles with convenience key: Press the handle in the luggage compartment lid ⇒ *page 40, fig. 29*. When the luggage compartment is locked, the vehicle key cannot be more than approximately 4 feet (1.5 m) away from the luggage compartment.

Closing the luggage compartment lid

- ▶ Press the  button in the luggage compartment lid. Or
- ▶ Press the handle in the luggage compartment lid ⇒ *page 40, fig. 29*. Or
- ▶ Press the luggage compartment lid downward slightly. Or
- ▶ When the ignition is switched on, pull the  switch in the driver's door ⇒ *page 40, fig. 30* until the luggage compartment lid is closed. Or
- ▶ Applies to: vehicles with convenience key: Press and hold the  button on the vehicle key while the ignition is switched off until the luggage compartment lid closes. Make sure there is enough distance (maximum of approximately 9 feet (3 m)) between you and the luggage compartment lid. Or
- ▶ Press the  button in the luggage compartment lid. Or
- ▶ Applies to: vehicles with convenience key: When the ignition is switched off, press the  /  button in the luggage compartment lid. The vehicle key must not be more than approximately 4 feet (1.5 m) away from the luggage compartment and it must not be inside the vehicle. If you press the * button, then the vehicle will lock.

Stopping automatic opening or closing

The automatic opening or closing of the luggage compartment lid will stop if:



- ▶ You press the  button or press the handle in the luggage compartment lid ⇒ *page 40, fig. 29* again. Or

- ▶ You press the  button on the convenience key*. Or
- ▶ Something blocks the luggage compartment lid or makes it difficult for the lid to move.

If you press the button  or the handle in the luggage compartment lid ⇒ *page 40, fig. 29* again, the luggage compartment lid will open or close again.

Storing the luggage compartment lid opening position

The position must be at a certain height or higher to store.

- ▶ Bring the luggage compartment lid into the desired open position. If you want to move the luggage compartment lid to a lower position, move it slowly in small increments; otherwise, the luggage compartment lid will close automatically.
- ▶ Press and hold the  button in the luggage compartment lid for at least four seconds to store the new opening position. A visual and audio signal will follow.
- ▶ To set a higher open position, wait at least five seconds and then carefully press the luggage compartment lid upward.
- ▶ Press and hold the  button again for at least four seconds to store the desired opening position.

Manually opening and closing the luggage compartment lid

If the electric motor malfunctions or the vehicle battery charge level is low, the luggage compartment lid can be opened or closed by hand. Extra force will be needed to do this. Move the lid slowly to reduce the amount of force needed.



- ▶ Pull the luggage compartment lid down slightly by the inside handle and then press on the lid until it latches.

WARNING

Observe the safety precautions ⇒ *page 39*.

Tips

If the luggage compartment lid is open while the vehicle key is inside the luggage

compartment or the passenger compartment, then the  / * buttons on the luggage compartment lid will be disabled.

Opening and closing the luggage compartment lid with foot motion (kicking movement)

Applies to: vehicles with sensor-controlled luggage compartment lid



Fig. 32 Vehicle rear: foot motion (example)

The luggage compartment lid can be opened and closed automatically  in *General information on page 39*.

Requirements: you must be carrying your convenience key* with you. The ignition must be switched off. You must be standing at the center behind the luggage compartment lid. Depending on vehicle equipment, it may also be possible to stand slightly off-center at the back of your vehicle.

- Move your foot back and forth under the bumper one time \Rightarrow *fig. 32*. Do not touch the bumper. Make sure you have firm footing. The luggage compartment lid will open or close once the system detects the movement. The automatic opening or closing will be canceled if you repeat one of the movements described.

WARNING

Observe the safety precautions \Rightarrow *page 39*.

WARNING

Please note that when you have the convenience key with you, the sensor-controlled luggage compartment lid could open or close unexpectedly during activity near the rear of the vehicle. This increases the risk of an accident.

Note

Please note that when you have the convenience key with you, the sensor-controlled luggage compartment lid could open or close unexpectedly during activity near the rear of the vehicle (for example, the lid could hit the ceiling in a garage).

Tips

The luggage compartment lid will only open or close if you perform the movement as described. This prevents the luggage compartment lid from opening or closing due to similar movements, such as when you walk between the rear of the vehicle and your garage door. In some situations, the function may be limited or temporarily unavailable. This may happen if:

- You are standing too close to the bumper or too far away from it
- The luggage compartment lid was closed or opened immediately beforehand
- You park close to a hedge and the branches move back and forth under the vehicle for a long period of time
- You clean your vehicle, for example with a pressure washer or in a car wash
- There is heavy rain
- The bumper is very dirty, for example after driving on salt-covered roads
- There is interference to the vehicle key's radio signal, such as from mobile devices or remote controls
- If the vehicle key is located in the luggage compartment or passenger compartment while the luggage compartment lid is open, then it will not be possible to close the luggage compartment lid using foot motions.

Manually unlocking the luggage compartment lid

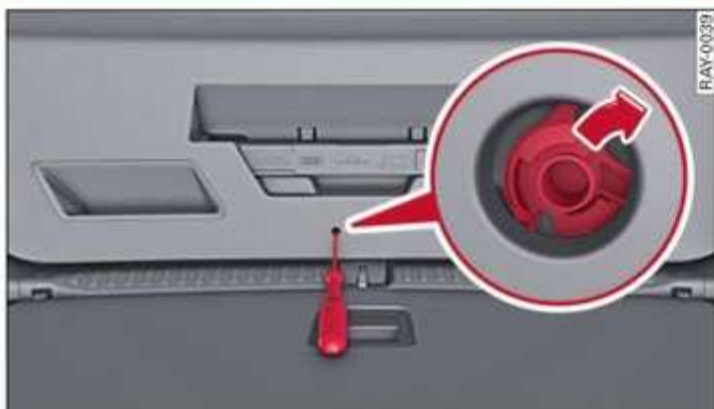

Fig. 33 Inner luggage compartment lid: access to the manual release

- ▶ Fold the backrest on the rear bench seat forward ⇒ *page 82*.
- ▶ To unlock the luggage compartment lid, press the lever in the direction of the arrow using a suitable object (such as a screwdriver).
- ▶ Fold the backrest backward until it locks into place.

WARNING

Observe the safety precautions ⇒ *page 39*.

WARNING

If you have folded the backrests into the upright position, always check if the lock is correctly engaged by pulling forward on the backrest.

Child safety lock

The child safety lock prevents the rear doors from being opened from the inside and the rear power windows from being operated.



Fig. 34 Driver's door: controls

- ▶ To activate and deactivate the child safety lock (for the interior door handle and power window switch) in a rear door, press the left or right  button in the driver's door that corresponds to that rear door ⇒ *fig. 34*. The LED in the button will turn on or off.
- ▶ Make sure the child safety lock is working by checking the function on the rear power window switch and door handle.

When the child safety lock is switched on, the following functions are disabled:

- The rear inner door handles
- The rear power windows
- The control panel* for the climate control system in the rear

Message in the instrument cluster display

The following messages may appear depending on the vehicle equipment:

Child safety lock: malfunction! Please contact Service

There is a malfunction in the child safety lock. Press the  button again.

If the message stays on, drive immediately to an authorized Audi dealer or authorized Audi Service Facility to have the malfunction repaired.

WARNING

- Observe the safety precautions ⇒ *page 33*.
- A malfunction in the child safety lock could allow the rear doors to be opened from the inside, which increases the risk of an accident.

Power windows

Opening and closing the windows

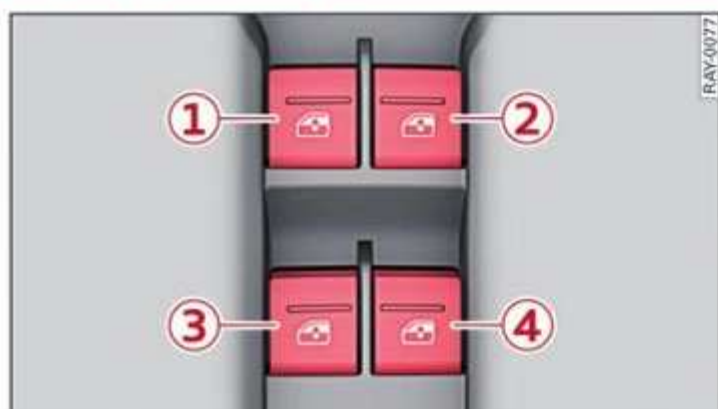

Fig. 35 Driver's door: power window switch

Power window switches:

- ① Left front door
- ② Right front door
- ③ Left rear door
- ④ Right rear door

Opening and closing the windows

All power window switches are equipped with a two-stage function:

- ▶ To open or close the window completely, press the switch down or pull the switch up briefly to the second level. The operation will stop if the switch is pressed or pulled again.
- ▶ To select a position in between opened and closed, press or pull the switch to the first level until the desired window position is reached.

Correcting a malfunction in the one-touch up/down function

If necessary, you can reactivate the one-touch up/down function if it malfunctions.

- ▶ Pull the power window switch up until the window is completely raised.
- ▶ Release the switch and pull it up again for at least one second.

WARNING

- Observe the safety precautions ⇒ *page 33*.
- Never close the windows carelessly or in an uncontrolled manner, because this increases the risk of injury.

Tips



- You can still open and close the windows for several minutes after turning the ignition off. The power window switch is not disabled until the driver's door or front passenger's door is opened.
- The power windows are equipped with pinch protection. The automatic window may stop closing and will open all the way again even if no obstacle is detected. Pull the power window switch up until the window is completely raised.

Convenience opening and closing

Applies to: vehicles with convenience key

Convenience opening and closing the windows and roof*

You can set in the MMI if all windows and the roof* should open all at once ⇒ *page 34, Setting the central locking system*.

- ▶ Press and hold the  button on the vehicle key until all windows and the roof* have reached the desired position ⇒ . Or
- ▶ Touch the sensor* on the door handle ⇒ *page 38, fig. 27* until all of the windows and the roof* are closed. Do not place your hand in the door handle when doing this.

When all of the windows and the roof* are closed, the turn signals will flash once.

WARNING

- Observe the safety precautions ⇒ *page 33*.
- Never close the windows or the roof* carelessly or in an uncontrolled manner, because this increases the risk of injury.

Tips

Applies to: vehicles with panoramic glass roof: If the sunshade is closed, it will automatically open when the roof is tilted.

Panoramic glass roof

Operating the panoramic glass roof and roof sunshade

Applies to: vehicles with panoramic glass roof and roof sunshade



Fig. 36 Headliner: controls for the panoramic glass roof ①, the roof ②, and for the sunshade

The system is controlled by swiping across or pressing the control pad ①/② ⇒ fig. 36. When opening or closing the roof or sunshade, you can stop the movement at any given position by touching the control pad again.

If the sunshade is closed, it will automatically open when the roof is tilted or opened.

Operating the roof

- ▶ Tilting the roof: press the control pad ↶ / ↷ in the headliner ①.
- ▶ Closing the roof when it is tilted: press on the control pad ↶ / ▽ in the headliner.
- ▶ Opening the roof: swipe your finger from the front to the back across the control pad ↶ in the headliner.
- ▶ Closing the roof: swipe your finger from the back to the front across the control pad ↶ in the headliner.

Operating the roof sunshade

The roof sunshade cannot be closed completely if the roof is open.

- ▶ Opening or closing the sunshade: swipe your finger from the back to the front across the control pad ↶ in the headliner ②, or press the corresponding symbol △ / ▽.

Roof emergency closing

If an object is detected when closing, the roof will open again automatically. In this case, you can then close it with the power emergency closing function.

- ▶ Tap the control pad ↶ in the headliner ① within five seconds after the automatic opening and swipe toward the front until your finger reaches ▽. Keep your finger in that location until the roof is closed.

! WARNING

- Observe the safety precautions ⇒ page 33.
- To reduce the risk of injury, always pay attention when closing the roof. Always switch the ignition off and take the key with you when leaving the vehicle.

! Note

Always close the roof when you leave the vehicle and when there is precipitation to reduce the risk of damage to the interior equipment, particularly the electronic equipment.

i Tips

- After switching off the ignition, the roof and sunshades can still be operated for several minutes as long as neither of the front doors have been opened.
- It is not possible to open the roof when temperatures are too low.

Garage door opener ¹⁾

Description

Applies to: vehicles with garage door opener

With the garage door opener, you can activate systems such as the garage doors, security systems or house lights from inside your vehicle. ▶

¹⁾ Not available in all countries.

These functions are operated in the MMI. Multiple receivers can be programmed, which can control the functions of up to eight¹⁾ hand-held transmitters.

WARNING

- When operating or programming the garage door opener, make sure that no people or objects are in the area immediately surrounding the equipment. People can be injured or property can be damaged if struck when closing.
- Do not allow yourself to be distracted from traffic by viewing and operating the center display.

Tips

- If you sell your vehicle, reset all settings to the factory default settings ⇒ *page 226*.
- The system complies with United States FCC regulations and ISED regulations ⇒ *page 291*.

Tips







- Before you program your system to the garage door opener, first check the compatibility:
- Ask an authorized Audi dealer or authorized Audi Service Facility or check at www.homelink.com. You can also find more information about HomeLink there.
 - You can display information about HomeLink (compatibility level/status/country code/HomeLink generation) in the MMI:
 - Select on the home screen: **VEHICLE > Settings & Service > Garage opener > ⓘ**.

Operation

Applies to: vehicles with garage door opener

Requirements: the remote control transmitter must be programmed ⇒ *page 46, Programming*, the vehicle must be within range of the system, and the ignition must be switched on.

There are multiple options to open or close the system (such as the garage door).

- ▶ To display the  button (**Garage opener**) for the garage door opener, press the  button in the status bar ⇒ *page 23*.
- ▶ If you have only programmed one remote control transmitter, press the  button in the status bar on the center display ⇒ *page 21*. Or
- ▶ If you have programmed multiple remote control transmitters, press the  button in the status bar on the center display ⇒ *page 21* and then press the button for the respective system. Or
- ▶ Applies to: vehicles with programmable steering wheel button: If you have configured the programmable steering wheel button, press the  button ⇒ *page 30*. Or
- ▶ Applies to: vehicles with GPS pairing: If you have programmed **Location pairing**, press the respective button in the center display (notification center ⇒ *page 23*). As you approach the system, the button is displayed on the MMI. Or
- ▶ When reverse gear is selected, the parking system* / rearview camera* / peripheral camera* will appear in the center display. To display the buttons of the first three garage door openers, press the  button in the status bar and then press the button for the respective system.

If transmission was successful, the message:

Send to: XXX will appear.

Programming

Applies to: vehicles with garage door opener

You can program both fixed code and rolling code systems in the MMI using the procedure that is described.

Requirement: the ignition must be switched on.

Programming the system

Applies to: MMI

Requirement: the hand transmitter must be present and the vehicle must be within range of the system (such as the garage door) that you ▶

¹⁾ The possible number of hand-held transmitters depends on the equipment.

would like to program. If you program more than three remote control transmitters, assign the first three spots to the systems that you would also like to use when driving in reverse.

- ▶ To display the  button for the garage door opener, press the  button in the status bar ⇒ *page 23*.
- ▶ If you are programming the garage door opener for the **first time**, press the  button on the center display. Follow the instructions in the MMI. Or
- ▶ If you would like to program **other** systems, select on the home screen: **VEHICLE > Settings & Service > Garage opener**. Select the desired button: . Follow the instructions in the MMI.
- ▶ If you would like to **reprogram** systems that are already programmed, select on the home screen: **VEHICLE > Settings & Service > Garage opener**. Press the  button and select  for the system to be reprogrammed. Select: **Program**. Follow the instructions in the MMI.

With some systems, the garage door opener will be immediately available after programming. With other systems, the garage door opener must also be synchronized.

Synchronizing¹⁾

Requirement: the hand transmitter must already be programmed and the vehicle must be within range of the system (such as the garage door).

If the system synchronization is performed directly after the programming procedure, follow the instructions on the MMI.

If you would like to sync at a later time:

- ▶ Applies to: MMI: Select on the home screen: **VEHICLE > Settings & Service > Garage opener**.
- ▶ Press the button for the system that you would like to synchronize.
- ▶ Follow the instructions in the MMI.

Location pairing

Applies to: vehicles with location pairing

For easier operation, you can program your system's location.

Requirements: the respective hand transmitter must be programmed ⇒ *page 46* and the vehicle must be located in front of the system.

- ▶ If you have programmed your system, follow the instructions in the MMI. Or

If you would like to set up location pairing at another time:

- ▶ Applies to: MMI: Select on the home screen: **VEHICLE > Settings & Service > Garage opener**.
- ▶ Press the  button.
- ▶ Press the  button for the system your vehicle is facing.
- ▶ Select: **Location pairing**.
- ▶ Follow the instructions in the MMI.

Only a maximum of three systems can be displayed in the notification center ⇒ *page 23*. If you would like to have all systems displayed, press .

Renaming programmed systems

You can rename the programmed systems according to your preferences (names may have a maximum of 10 characters).

- ▶ If you have programmed your system, follow the instructions in the MMI. Or

If you would like to change the name at another time:

- ▶ Applies to: MMI: Select on the home screen: **VEHICLE > Settings & Service > Garage opener**.
- ▶ Press the  button.
- ▶ Press the  button for the system that you would like to rename.
- ▶ Select: **Rename**. If necessary, delete the preset name, such as Garage door opener 1.
- ▶ Follow the instructions in the MMI.

Deleting programmed systems

The programmed systems can be deleted individually or all at once.

- ▶ Applies to: MMI: Select on the home screen: **VEHICLE > Settings & Service > Garage opener**.
- ▶ Press the  button. ▶

¹⁾ Only applies to rolling code systems

- ▶ To delete an **individual** system, press the  button for the desired system. If the checkmark ✓ is set, select: **Delete**.
- ▶ To delete **all** systems, select: **All > Delete**.

Tips

- Make sure the batteries in the hand transmitter are charged before starting the programming process.
- The programming process may take up to 30 seconds. It may be necessary for the hand transmitter to be pressed again in the meantime.
- The garage door opener may need to be synchronized with the system after programming. Follow the manufacturer's instructions for doing this.

Tips

- In some cases, the system may need to be programmed in a different mode ("D mode").
- Switch the ignition on.
 - Applies to: MMI: Select on the home screen: **VEHICLE > Settings & Service > Garage opener**.
 - Press and hold the desired button .
 - Select **Yes, in D mode** and follow the instructions on the MMI.

Lights and vision

Exterior lighting



Switching the lights on and off





Fig. 37 Instrument panel: light button module

① Light switch

Press and hold ① until the desired light function is selected. The selected function is displayed briefly in the instrument cluster. When switching on the ignition, the AUTO light function is automatically selected.

- AUTO - The automatic headlights adapt to the surrounding brightness automatically. The daytime running lights will automatically turn on. In vehicles for certain markets, you can switch the automatic daytime running lights on and off in the MMI.
-  - You can switch the low beam headlights on manually once the ignition is switched on.
-  - You can switch the parking lights on at speeds below 20 mph (32 km/h).
- USA models: OFF - You can switch off all light functions at speeds under 6 mph (10 km/h).
- Canada models: OFF - You can switch off all light functions when the ignition is switched off while the vehicle is stationary.

When the low beam headlights or parking lights are switched on, the respective  or  indicator light appears in the instrument cluster.

② All-weather lights

Applies to: vehicles with all weather lights

The headlights automatically adjust so that there will be less glare, for example when the road surface is wet.

Automatic headlight range control

Your vehicle is equipped with automatic headlight range control. It reduces glare for oncoming traffic if the vehicle load changes. The headlight range adjusts automatically.

Audi adaptive light

Applies to: vehicles with Audi adaptive light

Audi adaptive light provides better visibility when driving in the dark. The lights are adapted to the road conditions based on speed, such as when driving on expressways, rural roads, at intersections, and around curves. The adaptive light only functions when the automatic headlights are activated.

WARNING

- Observe the safety precautions and note the limits of the assist systems, sensors, and cameras ⇨ *page 129* to ⇨ *page 132*.
- Automatic headlights are only intended to assist the driver. The driver is still responsible for controlling the headlights and may need to switch them on and off manually depending on light and visibility conditions. For example, fog cannot be detected by the light sensors. So always switch on the low beams  under these weather conditions and when driving in the dark.

Tips

- If the vehicle battery has been discharging for a while, the parking light may switch off automatically. Avoid using the parking lights for several hours.
- When using lighting equipment, the driver is responsible for adhering to any local applicable regulations while driving and when parking the vehicle.
- Only the front headlights are on when the daytime running lights are switched on. In vehicles in certain markets, the tail lights will also turn on.
- In cool or damp weather, the inside of the headlights, turn signals, and tail lights can fog over due to the temperature difference between the inside and outside. They will clear shortly after switching them on. This

does not affect the service life of the lighting.

- When the parking lights are switched on and the ignition is switched off, the  symbol appears in the light switch module.

Turn signal and high beam lever

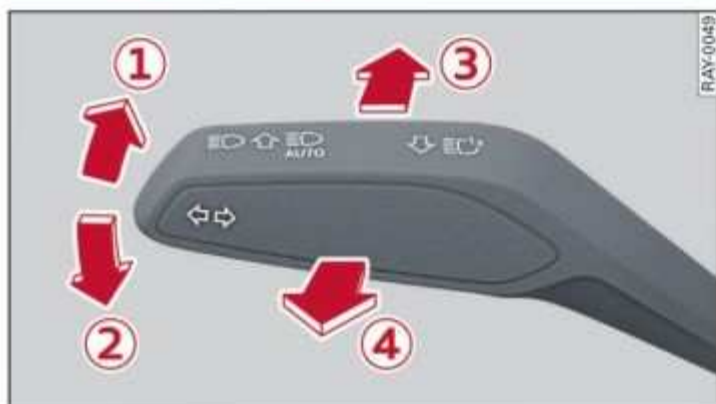



Fig. 38 Operating lever: switching the light functions on and off

The lever operates the turn signals, the high beams and the headlight flasher.

Turn signals

The turn signal will activate when you move the lever into a turn signal position while the ignition is switched on. The respective  or  indicator light will flash. The turn signal blinks three times if you tap the lever (convenience turn signal).

- ① Right turn signal
- ② Left turn signal

If an indicator light blinks twice as fast as usual, a turn signal bulb has failed. Carefully drive to an authorized Audi dealer or authorized Audi Service Facility immediately to have the malfunction corrected.

High beams and headlight flasher

► Move the lever to the corresponding position:

- ③ High beams on (vehicles with High beam assistant* ⇒ page 50)
- ④ High beams off or headlight flasher

The  indicator light in the instrument cluster will turn on.

WARNING

High beams can cause glare for other persons, which increases the risk of an accident. For this reason, only use the high beams or the headlight flasher when they will not create glare for other drivers.

High beam assistant

Applies to: vehicles with high beam assistant



The high beam assistant automatically turns the high beams on or off depending on the surrounding conditions.

A camera on the rearview mirror mount can detect light sources from other road users. The high beams switch on or off automatically depending on the position of vehicles driving ahead and oncoming vehicles, the vehicle speed as well as other environmental factors and traffic conditions.

Applies to: vehicles with Matrix LED headlights: With Matrix LED headlights ¹⁾, individual segments of the high beams are turned on or off. The area in front of the vehicle is dimmed, while the remaining area is illuminated. This allows for optimal lighting of the surrounding area without causing glare for other road users.

Activating high beam assistant

Requirement: the AUTO light function must be selected and the high beam assistant must be switched on in the MMI ⇒ page 51.

- To activate the high beam assistant, tap the lever forward ③ ⇒ page 50, fig. 38. The  indicator light will appear in the instrument cluster display and the high beams will be switched on or off automatically. If the high beams were completely or partially switched on, the  indicator light will turn on.

Activating and deactivating the high beam headlights manually

If the high beams did not switch on or off as expected, you may switch them on or off manually instead: ►

¹⁾ Not available in all countries.

- ▶ To activate the high beams manually, tap the lever forward **3** ⇒ page 50, fig. 38. The  indicator light will turn on.
- ▶ To deactivate the high beams manually, pull the lever back **4** ⇒ page 50, fig. 38. The high beam assistant is deactivated.

Operating the headlight flasher

- ▶ To operate the headlight flashers, pull the lever back **4** ⇒ page 50, fig. 38. If the high beam headlights are not switched on, the high beam assistant will remain activated.

WARNING

- Observe the safety precautions and note the limits of the assist systems, sensors, and cameras ⇒ page 129 to ⇒ page 132.
- High beam assistant is only intended to assist the driver. The driver is always responsible for controlling the high beam headlights and adjusting them based on the lighting and visibility conditions.
- High beams can cause glare for other persons, which increases the risk of an accident. For this reason, only use the high beams or the headlight flasher when they will not create glare for other drivers.

Tips

Adhere to any local applicable regulations when using the lighting equipment, for example in regard to reducing glare for other road users. The driver is always responsible for adhering to the regulations applicable in the country where the vehicle is being operated.

Adjusting the exterior lighting

The following settings depend on the vehicle equipment.

- ▶ Applies to: MMI: Select on the home screen: **VEHICLE > Light & Visibility > Exterior lighting**.

Automatic headlights

You can adjust the following settings in the **Automatic headlights** menu:

Activation time - You can adjust if the headlights switch on **Early**, **Medium**, or **Late** based on the sensitivity of the light sensor ¹⁾.

High beam assistant - You can switch the high beam assistant on and off.

Entry/exit lighting

The **Entry/exit lighting** illuminates the area around the vehicle when the vehicle is unlocked or when the driver's door is opened while the ignition is off. The entry/exit lighting works when it is dark and when the AUTO light function is switched on. The daytime running lights switch on automatically within the limits of the system each time the vehicle is unlocked, regardless of how bright it is outside the vehicle.

Daytime running lights

USA models: The daytime running lights can be switched on and off.

Canada models: This function cannot be switched off. They activate automatically each time the ignition is switched on.

Digital light signatures

You can choose from different light signatures, such as Light Design. The light signature is always active when the daytime running lights or the parking lights are active.

If you change to a different light signature, the change will go into effect shortly after you exit the vehicle.

¹⁾ This function was still in development at the time of printing.

Emergency flashers

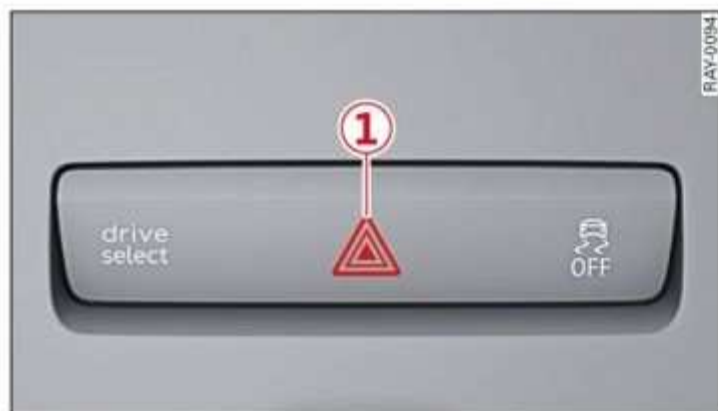

Fig. 39 Center console: emergency flashers

The emergency flashers help to make other road users aware of your vehicle in dangerous situations.

- ▶ Press the button to switch the emergency flashers on or off.

When the emergency flashers are turned on, the and indicator lights will flash at the same time.

You can indicate a lane change or a turn when the emergency flashers are switched on by using the turn signal lever. The emergency flashers stop temporarily.

The emergency flashers also work when the ignition is turned off.

Tips

You should switch the emergency flashers on if:

- you are the last car in a traffic jam so that all other vehicles approaching from behind can see your vehicle
- your vehicle has broken down or you are having an emergency
- your vehicle is being towed or if you are towing another vehicle

Messages

The following messages may appear depending on the vehicle equipment:

If the indicator light turns on, a bulb has failed. The displayed message indicates the cause and possible solutions. If one of the messages re-

mains on, drive immediately to an authorized Audi dealer or authorized Audi Service Facility to have the malfunction repaired.

Audi adaptive light: malfunction! See owner's manual

Adaptive light is not working. The headlights still function. Drive immediately to an authorized Audi dealer or authorized Audi Service Facility to have the malfunction repaired.

Headlight range control: malfunction! See owner's manual

There is a malfunction in the headlight range control system, which may cause glare for other road users. Drive to an authorized Audi dealer or authorized Audi Service Facility immediately to have the malfunction corrected.

High beam assistant: malfunction! See owner's manual

You can still switch the high beams on or off manually. Drive immediately to an authorized Audi dealer or authorized Audi Service Facility to have the malfunction repaired.

High beam assist.: currently unavail. Cam. view limited due to environment. conditions

This message appears if the camera's visual field is blocked. The system will switch itself off. Try switching the systems on later.

Automatic headlights: malfunction! See owner's manual

The light/rain sensor is malfunctioning. When the AUTO light function is on, the low beams will remain switched on at all times for safety reasons. Drive immediately to an authorized Audi dealer or authorized Audi Service Facility to have the malfunction repaired.

Interior lighting

Front interior lighting



Fig. 40 Headliner: front interior lighting

Interior lighting buttons

- ☰ ① – Interior lighting on/off.
- OFF ② – Door contact switch on/off. The interior lighting is controlled automatically.

Touch-sensitive reading lights

- ▶ To turn a reading light on or off, touch the surface ③ briefly.
- ▶ To activate the manual dimming function, touch the surface ③ when the light is switched off and keep touching it until the desired brightness is reached.

Rear interior lighting

Applies to: vehicles with rear reading lights

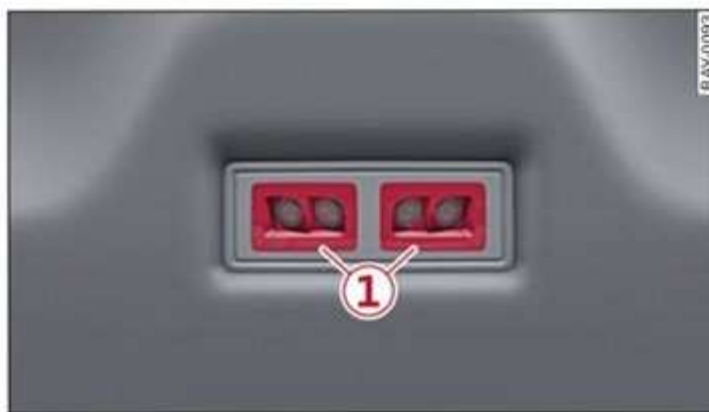

Fig. 41 Headliner: reading lights

Reading lights

- ▶ To turn a reading light on or off, touch the surface ① briefly.
- ▶ To activate the manual dimming function, touch the surface ① when the light is switched

off and keep touching it until the desired brightness is reached.

Interior lighting

Applies to: vehicles with interior lighting

The interior lighting is activated when the driver's door is opened. The interior lighting is deactivated when the lights are set to OFF.

The following settings depend on the vehicle equipment.

- ▶ Applies to MMI: Select on the home screen: **VEHICLE > Light & Visibility > Interior lighting.**

You can choose from various color profiles, such as **Maritime**.

Additional settings and profiles:

- **Brightness:** you can adjust the brightness for all of the interior lighting.
- **Individual:** you can adjust the brightness and color of the interior lighting separately for the line and surface lighting.
- **Audi drive select:** the line and surface lighting color changes depending on the selected drive select mode.

Display brightness

You can set the instrument and display illumination. The settings depend on the vehicle equipment.

- ▶ Applies to MMI: select on the home screen: **SETTINGS > Display & Brightness.**
- Cockpit dimming
- Head-up display
- MMI
- Audi virtual cockpit

Vision

Adjusting exterior mirrors

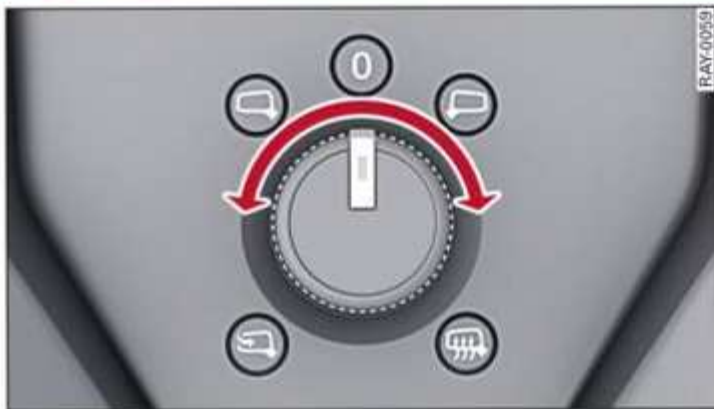

Fig. 42 Driver's door: knob for the exterior mirrors

► Turn the knob in the driver's door to the desired position:

0 – Deactivates all adjustment functions.

☞ / ☜ – Selects the left or right exterior mirror. To adjust the mirror glass in a mirror, press the knob in the desired direction.

☞☞ – Heats the mirror glass depending on the outside temperature.

☞ – Folds the exterior mirrors*. To fold the mirrors out, turn the knob to one of the other positions.

Front passenger's exterior mirror tilt function*

Requirement: the knob must be in the position for the front passenger's exterior mirror.

The mirror surfaces tilt slightly when reverse gear is selected to provide a better view, for example of the edge of the curb.

You can adjust the mirror surface by turning the knob in the desired direction.

The mirror moves from the reversing position back to the original position:

- When you switch the ignition off
- When you drive forward at speeds faster than 9 mph (15 km/h).
- When the knob is no longer in the position for the front passenger exterior mirror

WARNING

Curved mirror surfaces (for example convex) enlarge the field of vision. However, they make objects in the mirror appear smaller and farther away. When using these mirrors to estimate your distance to vehicles behind you when changing lanes, you could estimate incorrectly, which increases the risk of an accident.

Note

- Applies to: vehicles with power folding exterior mirrors: If the mirror housing was moved by outside forces (such as an impact when maneuvering), you must use the power folding function to fold the mirror all the way out. The mirrors will make a loud noise when they latch into place. The mirror housing must not be moved back into place by hand because this could impair the function of the mirror mechanism.
- Applies to: vehicles without power folding exterior mirrors: If the mirror housing was moved by outside forces (such as an impact when maneuvering), you must move it back in place by hand.
- If you wash the vehicle in an automatic car wash, you must fold the exterior mirrors in to reduce the risk of damage to the mirrors. Never fold power folding exterior mirrors* by hand. Only fold them in and out using the power controls.

Tips

If the power adjusting function malfunctions, the glass in both mirrors can be adjusted by pressing on the edge of it by hand.

Dimming the mirrors

Manual dimming rearview mirror

- Pull the lever on the bottom of the mirror back. ►

Automatic dimming rearview mirror

Applies to: vehicles with automatic dimming mirrors

- ▶ The interior and exterior mirrors dim automatically when light shines on them, for example from headlights on a vehicle behind you.

WARNING

Applies to: vehicles with automatic dimming mirrors

- Electrolyte fluid can leak out from broken mirror glass. This liquid can irritate the skin, eyes and respiratory system. If there is contact with the fluid, flush immediately with plenty of water. Seek medical attention if necessary.
- Repeated or long-term exposure to electrolyte fluid can lead to irritation of the airways, especially in people with asthma or other respiratory conditions. Take deep breaths immediately after leaving the vehicle or, if this is not possible, open all of the doors and windows as wide as possible.
- If electrolyte fluid comes into contact with the eyes, flush them thoroughly with plenty of clean water for at least 15 minutes and then seek medical attention.
- If electrolyte fluid comes into contact with the skin, flush the affected area with clean water for at least 15 minutes, and then clean with soap and water and seek medical attention. Clean affected clothing and shoes thoroughly before wearing again.
- If the fluid was swallowed and the person is conscious, flush the mouth with water for at least 15 minutes. Do not induce vomiting unless this is recommended by medical professionals. Seek medical attention immediately.

Note

Applies to: vehicles with automatic dimming mirrors

Electrolyte fluid can leak out from broken mirror glass. This liquid damages plastic surfaces and paint. Clean this liquid as quickly as possible, for example with a wet sponge.

Tips

Applies to: vehicles with automatic dimming mirrors

- If the light reaching the rearview mirror is obstructed, the automatic dimming mirror will not function correctly,
- The automatic dimming mirrors do not dim when the interior lighting is turned on or the reverse gear is selected.

Sun visors



Fig. 43 Roof headliner: sun visor

Sun visor

The sun visors can be moved out of their brackets and turned toward the doors ①.

They can also be moved back and forth lengthwise in this position.

Vanity mirror

The mirror light switches on when the cover over the vanity mirror ② opens.

Windshield wipers

Switching the windshield wipers on



Fig. 44 Lever: windshield wipers



Fig. 45 Lever: rear window wiper*

► Move the lever  to the corresponding position:

- ① Windshield wipers off
- ① Rain sensor/intermittent mode. The windshield wipers switch on once the vehicle speed exceeds approximately 2 mph (4 km/h) and it is raining. The higher the sensitivity of the rain sensor that is set (switch ⑥ to the right), the earlier the windshield wipers react to moisture on the windshield. You can deactivate the rain sensor mode, which switches the interval mode on. In intermittent mode, you can adjust the interval time using the switch ⑥.
- Applies to: MMI: Select on the home screen: **VEHICLE > Light & Visibility > Rain sensor.**
- ② Slow wiping
- ③ Fast wiping
- ④ Single wipe. If you hold the lever in this position longer, the wipers switch from slow wiping to fast wiping.

⑤ Clean the windshield . The number of wipes and afterwipes depends on how long the lever is held in position ⑤.

The wipers wipe one time after several seconds of driving to remove water droplets. You can switch this function off by moving the lever to position ⑤ within ten seconds of the afterwipe. The afterwipe function is reactivated the next time you switch the ignition on.

If you hold the lever in position ⑤ for longer than half a second, the edge wiping feature will be activated. This moves the windshield wipers closer to the edge of the windshield and performs an afterwipe to clean the residue that results from the wiping process from the edge of the windshield. The function is available when driving at speeds up to 75 mph (120 km/h).

The headlight washer system* operates only when the low beam headlights are on. If you move the lever into position ⑤, the headlights will be cleaned at regular intervals.

Applies to: vehicles with rear window wiper: ⑦ - Wiping the rear window . The number of wipes depends on the windshield wiper movement.

The rear wiper automatically switches on when the reverse gear is selected and the front windshield wipers are on and running.

Applies to: vehicles with rear window wiper: ⑧ - Cleaning the rear window . The number of wipes depends on how long the lever is held in position ⑧.

WARNING

- The rain sensor is only intended to assist the driver. The driver may still need to switch the wipers on manually depending on visibility conditions.
- The windshield must not be treated with water-repelling windshield coating agents. Under unfavorable conditions, such as wetness, darkness, and when the sun is low, these coatings can cause increased glare, which increases the risk of an accident. They can also cause wiper blade chatter.

– Properly functioning windshield wiper blades are required for a clear view and safe driving ⇒ *page 57, Cleaning/changing wiper blades.*

Note

- If there is frost, make sure the windshield wiper blades are not frozen to the windshield. Switching on the windshield wipers when the blades are frozen to the windshield can damage the wiper blades.
- Prior to using a car wash, the windshield wiper system must be switched off (lever in position 0). This prevents the wipers from switching on unintentionally and causing damage to the windshield wiper system.

Tips

- The windshield wipers switch off when the ignition is switched off. You can activate the windshield wipers after the ignition is switched on again by moving the lever to any position. The single wipe function (lever in position 4) also functions when the ignition is switched off.
- Worn or dirty windshield wiper blades result in streaking. This can affect the rain sensor function. Check your windshield wiper blades regularly.
- The washer fluid nozzles for the windshield washer system are heated when the ignition is on if the outside temperature is low.
- When stopping temporarily, such as at a traffic light, the speed of the windshield wipers automatically reduces by one level.

Cleaning/changing wiper blades

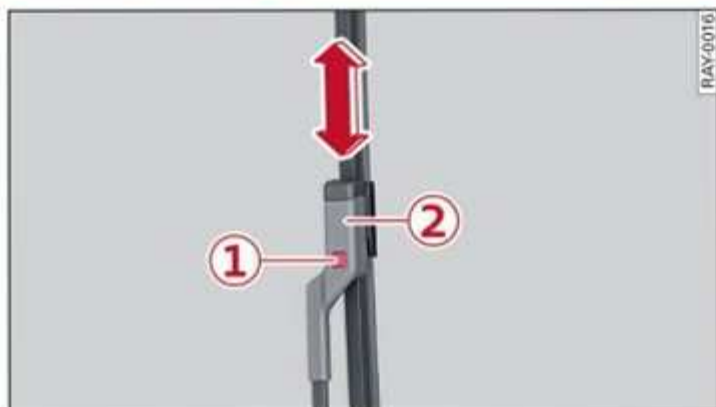

Fig. 46 Windshield wipers: changing the wiper blades

Wiper blade replacement position

- ▶ Switch off the ignition and hold the windshield wiper lever in position 4 ⇒ *page 56, fig. 44* until the windshield wiper moves into the wiper blade replacement position.
- ▶ To bring the windshield wipers into the normal position, switch the ignition on and hold the lever in position 4 until the windshield wipers go back to the original position, or drive faster than 8 mph (12 km/h).

You can also turn the wiper blade replacement position on or off in the MMI:

- ▶ Switch the windshield wipers off (position 0 ⇒ *page 56, fig. 44*).
- ▶ Applies to MMI: Select on the home screen: **VEHICLE > Settings & Service > Wiper change position.**

Cleaning the wiper blades

Requirement: the windshield wipers must be in the wiper blade replacement position.

- ▶ Fold the windshield wiper arm away from the windshield.
- ▶ For information on cleaning, see ⇒ *table on page 262.*

Replacing the wiper blades

Requirement: the windshield wipers must be in the wiper blade replacement position.

- ▶ Fold the windshield wiper arm away from the windshield.
- ▶ Hold the wiper blade firmly.
- ▶ Press the locking knob 1 on the wiper blade.
- ▶ Remove the wiper blade from the windshield wiper arm mount 2.
- ▶ Insert the new wiper blade into the mount on the wiper arm until it clicks into place.
- ▶ Place the wiper arm back on the windshield.
- ▶ Exit the wiper blade replacement position.

WARNING

- For safety reasons, the windshield wiper blades should be replaced once or twice each year.
- Dirty windshield wiper blades can impair vision, which increases the risk of an accident.

Note

- The windshield wipers must only be lifted up when in the wiper blade replacement position. Otherwise, you risk damaging the paint on the hood or the windshield wiper motor.
- You should not move your vehicle or press the lever when the wiper arms are folded up from the windshield. The windshield wipers would move back into their original position and could damage the hood and windshield.

Tips

- You can also use the wiper blade replacement position for other reasons, for example if you want to protect the windshield from icing by using a cover.
- You cannot activate the wiper blade replacement position when the hood is open.

Cleaning/changing the rear wiper blade

Applies to: vehicles with rear window wiper

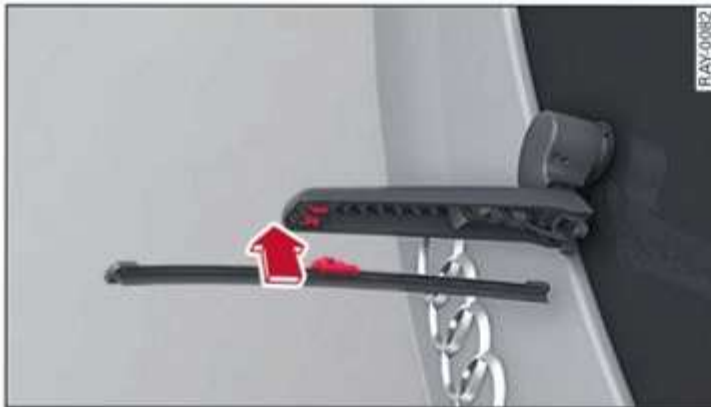

Fig. 47 Rear window wiper: installing the wiper blade

Cleaning the wiper blades

- ▶ Fold the wiper arm away from the rear window.
- ▶ For information on cleaning, see ⇨ *table on page 262*.

Removing the wiper blade

- ▶ Fold the wiper arm away from the rear window.
- ▶ Remove the wiper blade from its holder.

Installing the wiper blade

- ▶ Press the wiper blade mount into the retainer.
- ▶ Fold the window wiper arm back onto the rear window.

WARNING

For safety reasons, the windshield wiper blades should be replaced once or twice each year.

Messages

The following messages may appear depending on the vehicle equipment:

If the  indicator light turns on, then there is a windshield wiper malfunction. The message that is also displayed indicates the cause and possible solutions. If one of the messages does not turn off, drive immediately to an authorized Audi dealer or authorized Audi Service Facility to have the malfunction repaired.

Automatic wipers: malfunction! See owner's manual

The light/rain sensor is malfunctioning. You can still control all functions that are not controlled by the rain sensor using the windshield wiper lever. Drive immediately to an authorized Audi dealer or authorized Audi Service Facility to have the malfunction repaired.

Digital compass

Switching the compass on and off

Applies to: vehicles with digital compass

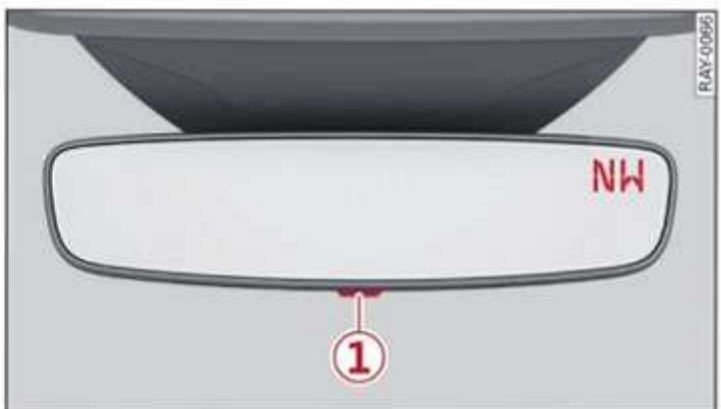



Fig. 48 Rearview mirror: digital compass is switched on

- ▶ To turn the compass on or off, press the button  until the compass display in the mirror turns on or off.

The digital compass only works when the ignition is turned on. The directions are indicated with ▶

abbreviations: **N** (north), **NE** (northeast), **E** (east), **SE** (southeast), **S** (south), **SW** (southwest), **W** (west), **NW** (northwest).

i **Tips**

To prevent inaccurate compass readings, do not bring any remote controls, electrical devices or metallic objects near the mirror.

Adjusting the magnetic zone

Applies to: vehicles with digital compass

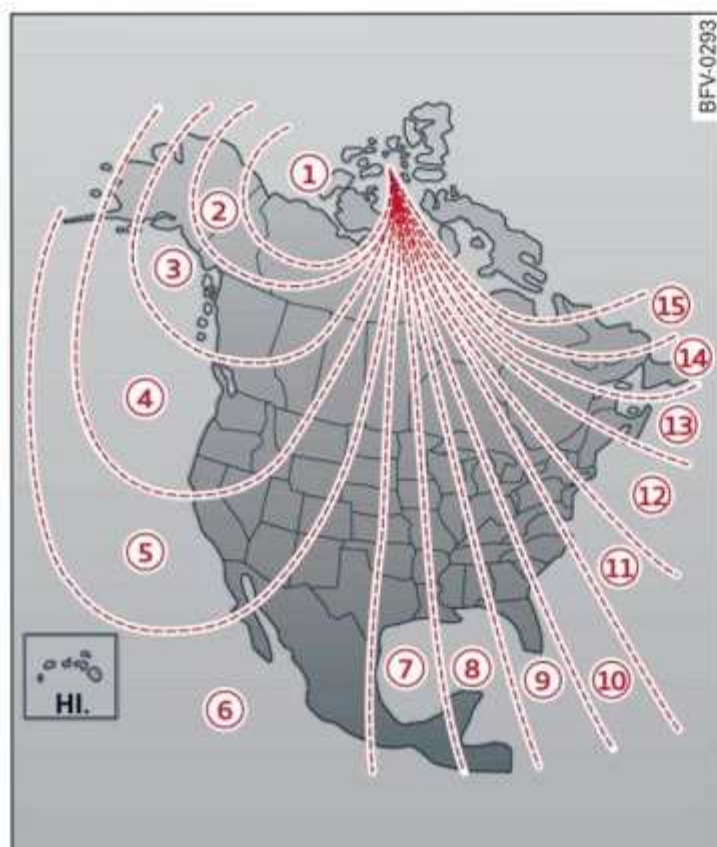

Fig. 49 Magnetic zone map

The magnetic zone must be adjusted correctly for the compass to read accurately.

- ▶ Press and hold the button ① ⇒ page 58, fig. 48 until the number of the magnetic zone appears in the interior rearview mirror.
- ▶ Press the button ① repeatedly to select the correct magnetic zone. The selection mode turns off after a few seconds.

Calibrating the compass

Applies to: vehicles with digital compass

If the display is incorrect or inaccurate, the compass must be recalibrated.

- ▶ Press and hold the button ① until a C ⇒ page 58, fig. 48 appears in the rearview mirror.
- ▶ Drive in a circle at about 6 mph (10 km/h) until a direction is displayed in the rearview mirror.

! WARNING

To reduce the risk to yourself and other road users, calibrate the compass in an area where there is no traffic.

Sitting correctly and safely

Maintaining the correct seating position

General information

As the driver, you are responsible for making sure each person in the vehicle is sitting correctly in their seat and maintaining this correct seating position while driving. Make sure that:

- Each person in the vehicle has adjusted their seat correctly ⇒ *page 60*
- The steering wheel is adjusted correctly ⇒ *page 63*
- The mirrors are adjusted so that there is a sufficient view of the area around the vehicle ⇒ *page 54*
- Each person in the vehicle has adjusted their head restraint correctly ⇒ *page 63*
- Each person in the vehicle has adjusted their safety belt correctly ⇒ *page 65*
- The activation status of the front passenger's airbag is suitable for the person in the front passenger's seat ⇒ *page 71*
- Children are secured in suitable child safety seats that are secured to appropriate vehicle seats ⇒ *page 73*. Read and observe the important safety information pertaining to the use of child safety seats on the front passenger's seat ⇒  *in General information on page 73*.

Examples of incorrect seating positions

Safety belts can only provide its optimal protection when they are routed correctly. Incorrect seating positions significantly reduce the protective functions of the safety belts and increase the risk of injury due to incorrect belt routing.

The following list includes examples of seating positions that could be dangerous for all vehicle occupants. This is not a complete list. Audi would simply like to increase your awareness of the topic. The following points apply when the vehicle is in motion:

- Never stand inside the vehicle.
- Never stand on the seats.

- Never kneel on the seats.
- Never tilt your backrest too far back.
- Never lean against the instrument panel.
- Never lie down on the rear bench seat.
- Never sit only on the front section of the seat.
- Never sit sideways on the seat.
- Never lean against the window.
- Never place your feet out of the window.
- Never place your feet on the instrument panel.
- Never place your feet on the seat cushion.
- Never ride in the footwell.
- Never sit on the armrests.
- Never drive or ride in a seat without fastening your safety belt.
- Never ride in the luggage compartment.

WARNING

Incorrect seating positions, failure to wear a safety belt, or being too close to an airbag increase the risk of serious or fatal injury to vehicle occupants, especially if the airbags deploy and come into contact with occupants who are not seated correctly. Note the important information and warnings in the chapters for the topics given above.

Tips

If you or other passengers in the vehicle have physical limitations that prevent sitting in a correct position, modifications to the vehicle may be necessary. For more information, contact an authorized Audi dealer or authorized Audi Service Facility, or call Audi customer support at 1-800-822-2834.

Front seats

General information

Make sure that:

- You can press the pedals down completely while your legs are slightly bent.
- The distance between your upper body and the steering wheel or instrument panel is at least 10 inches (25 cm).
- The distance between your knees and the instrument panel is at least 4 inches (10 cm). ▶

- Your thighs are lightly supported by the front surface of the seat.
- The backrest is in an upright position and the back of the person seated is resting against it.
- You have a sufficient view of the area around the vehicle.
- You have a clear view of the instrument cluster, indicator lights, and the head-up display*.

WARNING

- If you are too close to the steering wheel or instrument panel, the airbag system cannot provide the optimal protection, which increases the risk of injury and death.
- To reduce the risk of injury to the driver in the event of sudden braking maneuvers or accidents, never drive with the backrest reclined very far. The airbag system and safety belts can only provide optimal protection when the backrest is in an upright position and the driver is wearing the safety belt correctly. If the backrest is angled back too far, the safety belt can shift to soft areas of the body, such as the stomach, which increases the risk of injury.
- To reduce the risk of an accident, only adjust the seats when the vehicle is stationary.
- Be careful when adjusting the seat. Lack of control or attention when adjusting can result in injuries due to pinching for vehicle occupants both in the front seats and rear seats.
- Never place objects in the driver's footwell. Objects could shift and enter the area around the pedals, which could prevent you from using them. You would then be unable to use the pedals if sudden driving or braking maneuvers were needed, which increases the risk of an accident.
- Make sure that the floor mats are always securely attached.
- To reduce the risk of an accident, never place additional floor mats or other floor covers over the installed floor mats, because this reduces the pedal's range of motion and can impair pedal operation.
- To reduce the risk of injury, never place your feet on the instrument panel, out of the

window, or on the seat surfaces. This also applies to persons in the rear seats.

Note

To reduce the risk of damage, be very careful when adjusting the seat to make sure the head restraints do not come into contact with the roof.

Manual seat adjustment

Applies to: vehicles with manual adjustable seats



Fig. 50 Front seat: adjusting the seat

The settings depend on the vehicle equipment.

Adjusting the seat position

- ▶ To adjust the seat forward or back, pull the lever **1** and slide the seat.
- ▶ To adjust the seat up or down, pull or press the lever **2**.

Adjusting the backrests

- ▶ To adjust the backrest forward or back, turn the adjusting wheel **3**.

Adjusting the upper thigh support

- ▶ To increase or decrease the upper thigh support, lift the handle **4** and move the upper thigh support.

Adjusting the angle of the seat surface

- ▶ To adjust the angle of the seat surface, pull or press the lever **5**.

Adjusting the lumbar support

- ▶ To adjust the lumbar support, press the button **6** in the desired direction. ▶

WARNING

- To reduce the risk of an accident, only adjust the driver's seat when the vehicle is stationary.
- Exercise caution when adjusting the seat height. Adjusting the seat carelessly or without checking can pinch hands and fingers.
- The front seat backrests must not be reclined too far back when driving, because this impairs the effectiveness of the safety belts and airbag system, which increases the risk of injury.

Power seat adjustment

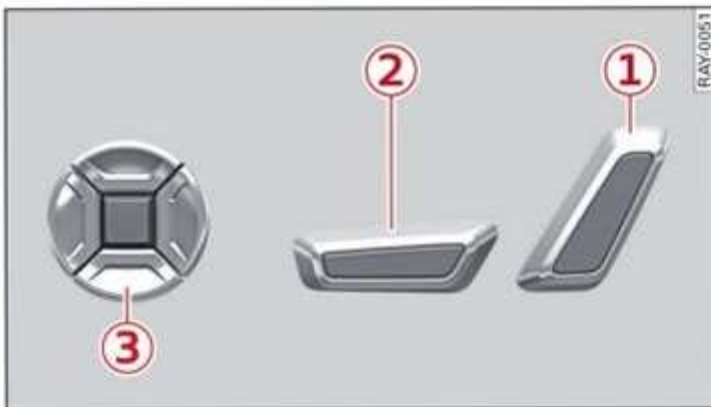

Fig. 51 Front seat: seat adjustment buttons

The settings depend on the vehicle equipment.

Adjusting the backrests

- ▶ To move the backrest forward or backward, press the button ① forward or backward.

Adjusting the seat position

- ▶ To move the seat forward or backward, push the button ② forward or backward.
- ▶ To adjust the seat upward or downward, push the rear section of the button ② upward or downward.
- ▶ To adjust the seat surface, press the front part of the button ② upward or downward.

Adjusting the lumbar support

- ▶ To adjust the lumbar support, press the button ③ in the desired direction.

Adjusting the upper thigh support

- ▶ To lengthen or shorten the upper thigh support, lift the handle at the front of the seat and move the upper thigh support.

WARNING

- To reduce the risk of an accident, only adjust the driver's seat when the vehicle is stationary.
- The power front seats can also be adjusted when the ignition is switched off. To reduce the risk of injury, children should never be left unattended in the vehicle for this reason.
- Exercise caution when adjusting the seat height. Unsupervised or careless seat adjustment could cause parts of the body to get pinched, which increases the risk of injury.
- The front seat backrests must not be reclined too far back when driving, because this impairs the effectiveness of the safety belts and airbag system, which increases the risk of injury.

Front center armrest

Applies to: vehicles with a front center armrest



Fig. 52 Cockpit: center armrest

The front center armrest is located between the front seats.

Adjusting the center armrest

The settings depend on the vehicle equipment.

- ▶ Press the button ① to raise or lower the armrest.
- ▶ To adjust the armrest forward or backward, move the armrest in the desired direction. ▶

- ▶ To adjust the angle, raise the armrest in stages.
- ▶ To move the armrest back into the original position, raise it slightly out of the top level and fold it downward.

WARNING

- Loose objects can be thrown around the vehicle interior during sudden driving or braking maneuvers, which increases the risk of an accident. Store objects securely while driving.
- In certain positions, the front center armrest can interfere with arm movement, which increases the risk of injury.

Steering wheel

General information

Make sure that:

- The distance between your upper body and the steering wheel is at least 10 inches (25 cm).
- Your arms are bent slightly at the elbows.
- You have a sufficient view of the area around the vehicle and you have a clear view of the instrument cluster and head-up display*.
- You are always holding the steering wheel with both hands on the outer edge at the sides (9:00 and 3:00 position) when driving.

WARNING

- To reduce the risk of an accident, make sure the steering wheel is adjusted correctly and cannot be moved out of position before you start to drive.
- If you are too close to the steering wheel, the driver's airbag cannot provide optimal protection, which increases the risk of injury or fatality.
- Never hold the steering wheel in the 12:00 position or in any other way, such as holding the center of the steering wheel. Otherwise, your arms, hands, and head could be injured in the event that the driver's airbag deploys.

Adjusting the steering wheel position manually

Applies to: vehicles with manual steering wheel adjustment

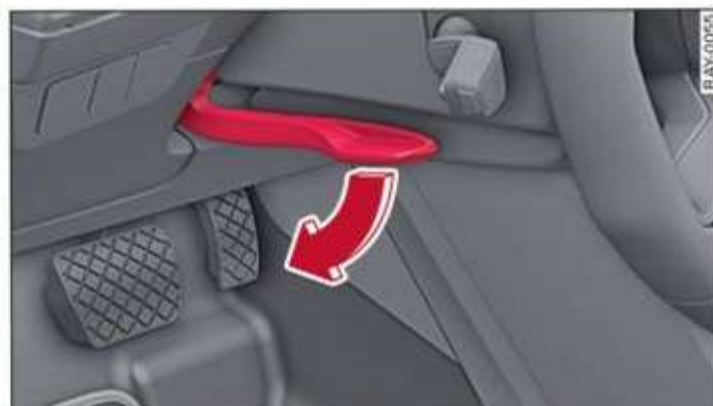

Fig. 53 Steering column: lever for adjusting the steering wheel position

The steering wheel position is adjustable up and down and forward and back.

- ▶ Press the lever in the direction of the arrow.
- ▶ Bring the steering wheel into the desired position.
- ▶ Push the lever all the way up until it engages.

WARNING

- To reduce the risk of an accident, only adjust the steering wheel before you start driving.
- Push the lever upward firmly so that the steering wheel position does not change unintentionally while driving, which would increase the risk of an accident.

Head restraints

General information

Applies to: vehicles with adjustable head restraints

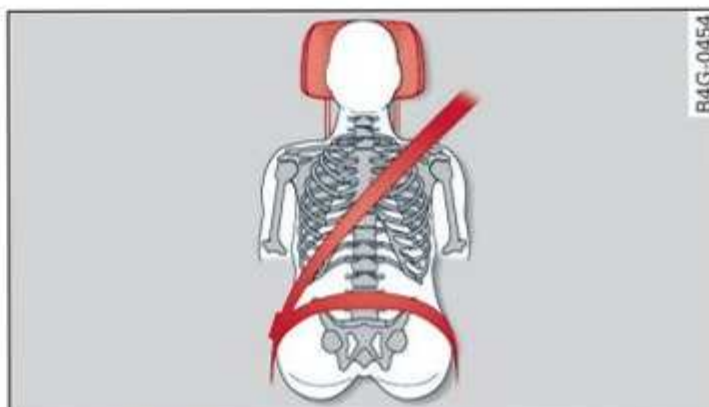

Fig. 54 Correctly-adjusted head restraint

Make sure that: ▶

- The upper edge of the head restraint is as even as possible with the top of your head.
- The head restraint is as close as possible to the back of the head.
- The head restraints in any occupied rear seats are all the way up.

WARNING

- There is one head restraint for each seat. All vehicle occupants must adjust the head restraints correctly before every trip. Having head restraints that are not adjusted correctly or not installed in the vehicle increases the risk of a neck injury during sudden or unexpected driving or braking maneuvers or in a collision.
- Only remove the rear seat head restraints if it is necessary to install a child safety seat ⇒ *page 73*. Stow the removed head restraints securely, for example in the luggage compartment. Reinstall the head restraints immediately once the child safety seat has been removed. Driving without head restraints increases the risk of serious neck injuries.

Front head restraints

Applies to: vehicles with adjustable head restraints



Fig. 55 Front seat: adjusting the head restraint

The settings depend on the vehicle equipment.

Adjusting the head restraints

- ▶ To adjust the head restraint upward, downward, or backward, press the button on the side and slide the head restraint. Release the button and slide the head restraint farther until it locks into place.

- ▶ To adjust the head restraint to the front, slide it until it locks into place.

Rear head restraints

Applies to: vehicles with adjustable head restraints



Fig. 56 Rear seat: adjusting or removing the head restraint

Adjusting the head restraints

- ▶ To adjust the head restraint upward, slide it until it locks into place.
- ▶ To adjust the head restraint downward, press the button ② and slide the head restraint. Release the button and slide the head restraint farther until it locks into place.

Removing the head restraints

Applies to: vehicles with removable head restraints

- ▶ Fold the backrest forward slightly ⇒ *page 82*.
- ▶ Move the head restraint upward all the way.
- ▶ Press the button ② ⇒ *fig. 56*. If the head restraint is equipped with another button, then also press that button ①. Pull the head restraint out of the backrest at the same time ⇒  in *General information on page 64*.

Installing the head restraints

- ▶ Fold the backrest forward slightly ⇒ *page 82*.
- ▶ Slide the posts on the head restraint down into the guides until the posts click into place.
- ▶ Press the button ② and slide the head restraint all the way down. It should not be possible to remove the head restraint from the backrest without pressing the button.

Safety belts

General information

Each seat is equipped with a three-point safety belt. Safety belts that are worn correctly are the most effective way to reduce the risk of serious or fatal injuries in a collision. Therefore, wear your safety belt correctly and make sure that all persons in the vehicle are also wearing their safety belts correctly when the vehicle is moving.

Even though your vehicle is equipped with an air-bag system, each person in the vehicle must still always wear the appropriate safety belt. In addition to their normal protective function, safety belts also hold vehicle occupants in the correct seating position in the event of a collision so that the airbags can deploy correctly and provide additional protection. Safety belts provide protection during collisions when the airbags do not deploy or if they have already deployed.



WARNING

The risk of serious or fatal injury increases if the safety belt is not fastened, if it is worn incorrectly, or if it is damaged.

- All vehicle occupants, including the driver, must fasten their safety belts correctly before every trip and must always keep their safety belts fastened during the trip, regardless of whether the seat is equipped with an airbag or not. This also applies to children that are seated in a child safety seat that is appropriate for their weight and age and that is secured with a safety belt.
- In the event of a collision, vehicle occupants who are not wearing safety belts could be propelled through the vehicle interior and collide with vehicle components, such as the steering wheel, instrument panel, windshield, or doors. In some situations, vehicle occupants could also be ejected from the vehicle. Vehicle occupants in the rear seats who do not wear safety belts not only endanger themselves, but also other persons in the vehicle.
- Only one person may be fastened with a safety belt at a time. Never secure more

than one person, including children, with a single safety belt.

- Never allow children or infants to ride on another person's lap and be belted into the safety belt with them.
- Insert the belt buckle only in the belt latch belonging to the corresponding seat, so that the protective function is not impaired.
- To ensure the maximum protective function of the safety belts, all persons in the vehicle must sit in the correct seating position ⇒ *page 60*.
- Check the condition of your vehicle's safety belts regularly ⇒ *page 262*. If you find damage to the belt webbing, the belt connections, the retractor, or the buckle, have the damaged safety belt replaced by an authorized Audi dealer or authorized Audi Service Facility.
- The safety belts must not be removed or modified in any way. Do not attempt to repair the safety belts yourself.
- Safety belts that are strained during an accident must be replaced by an authorized Audi dealer or authorized Audi Service Facility.

Correct safety belt positioning

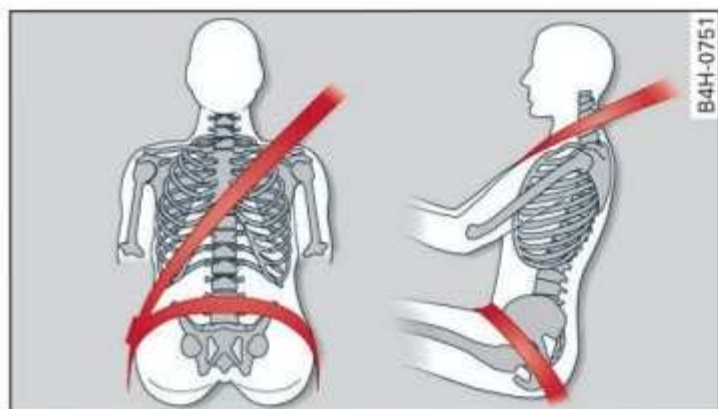

Fig. 57 Lap/shoulder belt positioning



Fig. 58 Safety belt positioning for pregnant women

Fastened safety belts only offer optimal protection during an accident and reduce the risk of serious injury or death when they are positioned correctly. Furthermore, the correct safety belt position holds the vehicle occupant in place so that a deployed airbag can provide maximum protection. Therefore, always fasten the safety belt and make sure it is positioned correctly ⇒ *fig. 57*.

To ensure the safety belt is positioned correctly, make sure of the following points:

- The lap portion of the safety belt must be located across the lap.
- The shoulder portion of the safety belt must rest over the center of the shoulder.
- The safety belt must always rest flat and securely on the body.

For pregnant women, the safety belt must rest evenly across the chest and as low and flat as possible on the lap, so that no pressure is applied to the lower abdomen. This should be done throughout the entire pregnancy ⇒ *fig. 58*.

! WARNING

Incorrect safety belt positioning can cause serious injury in the event of an accident or during sudden braking or driving maneuvers.

- Never drive with the backrest reclined extremely far. The more the backrest is tilted back, the greater the risk of injury due to the safety belt being routed incorrectly.
- The safety belt itself or a loose safety belt can cause serious injuries if it shifts onto soft areas of the body, such as the stomach.
- The shoulder portion of the safety belt must lie over the center of the shoulder and chest, and never under the arm, behind the back, or across the neck or face.
- The lap portion of the safety belt must lie across the lap and never over the stomach.
- The safety belt must lie flat and securely on the upper part of the body and the lap.
- The belt webbing must not be pinched or twisted, or rub against sharp edges.
- If the safety belt height is set incorrectly and/or the safety belt is routed incorrectly, then the safety belt's protective function will be impaired in the event of an accident. Make sure the safety belt is at the right height and is routed correctly for the person in the vehicle who is using it.
- A safety belt that is too loose may lead to injuries during an accident, because your body will move farther forward due to kinetic energy and will be stopped abruptly by the belt.
- Heavily bulky, loose clothing (for example, a coat over a sports jacket) may prevent the seat and safety belts from functioning correctly.
- Do not position the safety belt over hard or breakable objects (such as glasses, pens, etc.).
- The lap belt portion of the safety belt must sit as low as possible on the lap of pregnant women and lie flat under the belly.

! Note

Make sure that there are no hook-and-loop fasteners or sharp objects such as zippers or

rivets on clothing in the area where the safety belt is worn. Otherwise, the safety belt could be damaged.

Fastening and unfastening safety belts



Fig. 59 Belt buckle and belt latch



Fig. 60 Releasing the belt buckle from the belt latch

Observe the safety precautions ⇨ *page 65*.

Fastening the safety belt

- ▶ Pull the safety belt by the belt buckle evenly across your chest and lap.
- ▶ Insert the belt buckle in the belt latch belonging to the seat until it audibly engages ⇨ *fig. 59*.
- ▶ Pull on the belt to make sure that the belt is securely locked in the latch.

Unfastening the safety belt

- ▶ Press the red button on the belt latch ⇨ *fig. 60*. The belt buckle will pop out.
- ▶ Guide the belt back by hand so that the safety belt can roll up more easily.

Safety belt monitoring system

 - If the indicator light turns on or flashes, a front safety belt is not fastened or it has been un-

fastened while driving. There may be additional audible warning signals.

Adjusting the height of the safety belt



Fig. 61 Belt height adjustment for the front seats - safety belt relay

- ▶ To move the belt higher, slide the safety belt relay ② upward.
- ▶ To move the belt lower, press the release button ① and slide the safety belt relay ② downward.
- ▶ To check if the safety belt relay is securely locked in place, pull firmly on the belt.

Tips

You can also adjust the height of the front seats to change the position of the safety belts.

Additional safety belt functions

Belt retractor lock

The safety belts on the rear seats and on the front passenger seat are equipped with a belt retractor lock.

- ▶ If you secure a child safety seat with a safety belt, the belt retractor lock on the safety belt may need to be activated. Follow the instructions from the child safety seat manufacturer.
- ▶ When a person in the vehicle has fastened a safety belt, the belt retractor lock should not be activated. If the belt retractor lock has been activated unexpectedly, deactivate it.

Deactivating or activating the belt retractor lock ⇨ *page 76*.

Safety belt retractor

The safety belts are equipped with an automatic belt retractor. This automatic retractor allows the safety belt to be pulled all the way out when the belt is pulled slowly. However, the automatic retractor locks during sudden braking maneuvers. It also locks the belts when accelerating, driving uphill, and driving around curves.

Belt force limiter

Safety belts with belt force limiters reduce the force placed on the body by the safety belts during a collision.

Safety belt pretensioners

In certain driving situations, safety belts may be tightened with reversible belt tensioners when you start driving. If the safety belt is too loose, it will be tightened so that the belt will rest closer to the body.

In some collisions, pyrotechnic belt tensioners may secure the safety belts so that they cannot loosen. This reduces forward movement of the persons in the vehicle.

WARNING

The pyrotechnic system can only provide protection during one collision. If the pyrotechnic belt tensioners deploy, the pretensioning system must be replaced by an authorized Audi dealer or authorized Audi Service Facility.

Tips

Smoke may be released when pyrotechnic belt tensioners deploy. This is not a sign of a vehicle fire.

Memory function

General information

Applies to: vehicles with memory function

With the memory function, you can save and call up seat profiles using the memory buttons in the door trim panel.

Depending on vehicle equipment, some settings such as the driver's seat and exterior mirror position can be stored.

Storing and recalling a seat profile

Applies to: vehicles with memory function

The memory function buttons are located in the door trim panel.

Storing a seat profile

- ▶ Press the **SET** button. If the LED in the button turns on, a seat profile can be stored.
- ▶ Push one of the numbered memory buttons. A tone confirms that the settings were stored.

Recalling a seat profile

- ▶ When the a door is open and the ignition is switched off, press the memory button once briefly. The seat will be fully adjusted to the settings in the seat profile.
- ▶ If the door is closed or the ignition is switched on, press and hold the memory button until the seat is fully adjusted to the settings in the seat profile.

WARNING

- To reduce the risk of an accident, the seat setting can only be recalled when the vehicle is stationary.
- In an emergency, the recall process can be canceled by pressing the seat adjustment button on that seat.

Airbag system

General information

WARNING

- If you have not fastened your safety belt, you are in an incorrect seating position, or you are too close to the airbag system, the airbag system will not be able to protect you. This increases the risk of serious or fatal injuries. Make sure that each person in the vehicle has their safety belt fastened correctly and is sitting in a correct seating position ⇨ *page 60*. This is necessary

regardless of whether the seat is equipped with an airbag or not.

- Never place your feet on the instrument panel, out of the window, or on the seat surfaces. To help ensure that the airbag system can deploy correctly, never bend forward or lean on the door or the side window. Otherwise, serious and possibly fatal injuries can occur if the airbags deploy.
- People, animals, or objects between the vehicle occupants and the airbag system can interfere with the correct deployment of the airbag or can be propelled through the vehicle interior, increasing the risk of serious or fatal injuries. Make sure that nothing is located between the vehicle occupants and the airbag system. Do not secure or transport any objects within the deployment zone of the airbag systems, especially on the steering wheel, on the instrument panel, on the doors, on the windows, or in the footwell.
- Never put stickers on the airbag system covers or cover them with any objects.
- Only lightweight clothing should be hung from the garment hooks in the vehicle. Do not use clothes hangers to hang clothing. The pockets of the clothing must not contain any heavy, breakable, or sharp-edged objects. This could impair the effectiveness of the side curtain airbags.
- You must not use seat or protective covers that are not specifically approved for use on Audi seats with side airbags. Since the side airbags deploy from the seat backrest, such covers could impair the protective function of the side airbags.
- Damage to the original seat covers in the airbag deployment area must always be repaired by an authorized Audi dealer or authorized Audi Service Facility.
- Airbag system components are installed at various locations in your vehicle. Incorrect work or repairs on the vehicle could damage the airbag system components or impair their functionality. This may prevent the airbags from deploying or cause them to deploy incorrectly in the event of an accident,

which increases the risk of serious or fatal injuries. Only have an authorized Audi dealer or authorized Audi Service Facility make repairs or modifications to a vehicle.

- The airbag system can only provide protection during one collision. If there is another collision, the airbag system will not deploy again. If the airbag system has deployed, have it replaced immediately by an authorized Audi dealer or authorized Audi Service Facility.
- Fine dust may appear if the airbags deploy. This is completely normal and does not indicate a fire in the vehicle. The fine dust can irritate the skin and mucous membranes in the eyes and can cause difficulty breathing, particularly for individuals who have or have had asthma or other health issues that affect breathing. Exit the vehicle or open the windows or doors to get access to fresh air.

Tips

If you are transporting children in the vehicle, read the information and follow the safety precautions → page 73.

Safety systems monitoring

The  indicator light in the instrument cluster monitors the safety systems such as the airbags (including the control modules, sensor, and wiring) and the belt tensioners. It turns on when you switch the ignition on and turns off after several seconds.

If the indicator light does not turn on when the ignition is switched on, does not turn off after several seconds, or turns on or flashes while driving, there may be a malfunction in one of the safety systems. Drive to an authorized Audi dealer or authorized Audi Service Facility immediately to have the malfunction corrected.

WARNING

Have the malfunction in the safety systems inspected immediately. Otherwise, there is a risk that the systems may not activate during

an accident, which increases the risk of serious or fatal injury.

Description

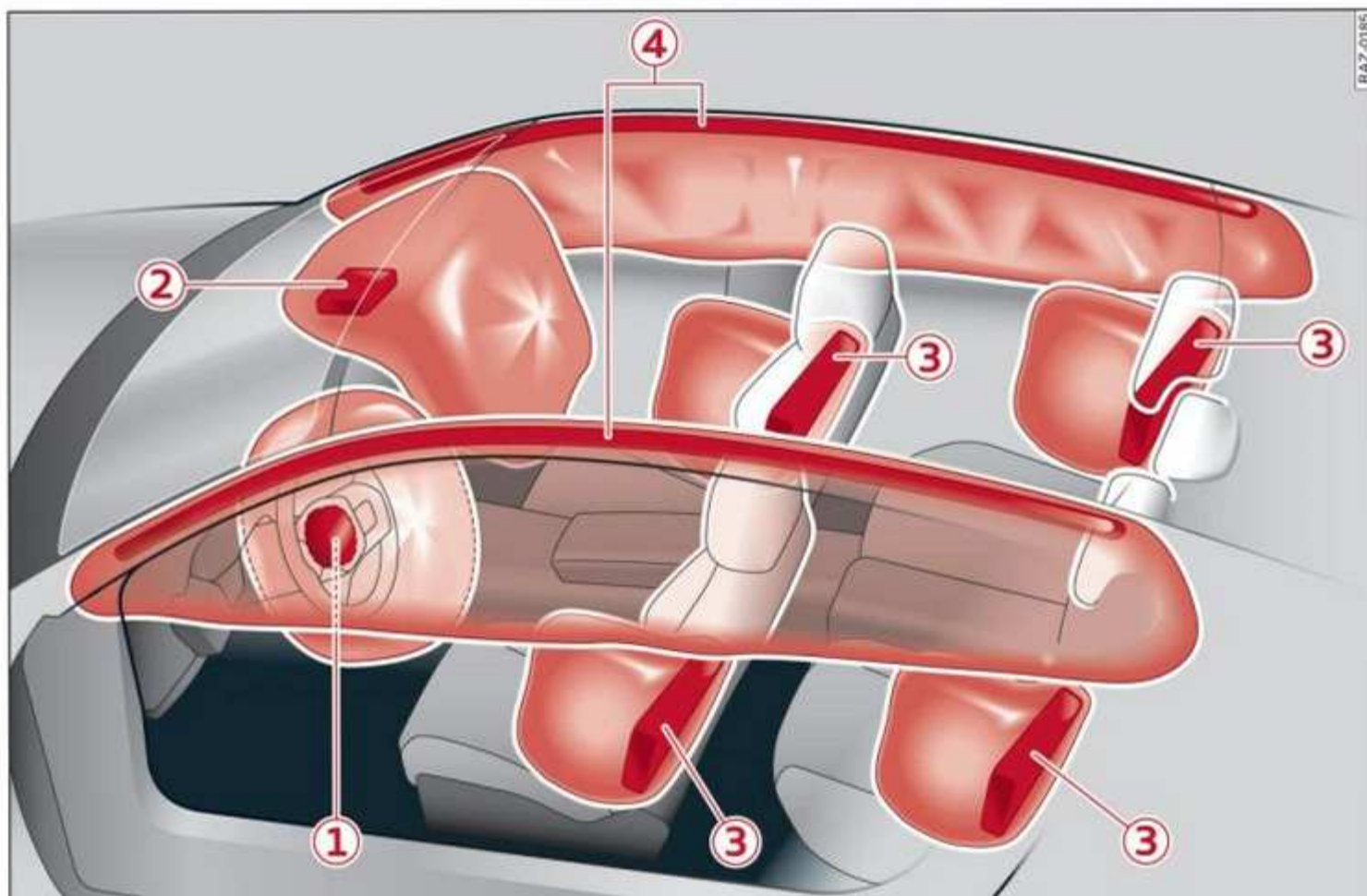

Fig. 62 Airbag overview image (enlarged section: deployed airbags)

The locations of the airbags are labeled with "AIRBAG". The following airbags are installed in your vehicle:

- ① Driver's airbag
- ② Front passenger's airbag
- ③ Front side airbags and rear, if applicable
- ④ Head curtain airbag with ejection mitigation

Airbags offer the best possible protection in your vehicle during an accident when they are used together with safety belts that are fastened correctly, and when passengers are sitting in the correct seating position. Airbags are a supplementary restraint system and do not replace safety belts.

Airbags may deploy during front-impact, side-impact, or rollover accidents.

The deployment area for the airbag system cannot be defined for every situation, since the circumstances surrounding accidents can vary widely. Factors that play an important role include the condition of the object that the vehicle hits (hard or soft), the angle of impact, vehicle speed, etc. The deciding factor for the deployment of the airbag system is the deceleration that occurs during an accident. Sensors in the vehicle are designed to detect the severity of an accident in conjunction with the control module, and to provide a targeted and timely deployment of the restraint system. If the vehicle deceleration that is measured during an accident is below the specified reference values in the control module, then the airbags will not deploy, even though the vehicle may be severely damaged from the accident. In these cases, the vehicle occupants will be protected by the safety belts if they are fastened and worn correctly.

The deployment of the front passenger's airbag will depend on the occupancy of the seat
⇒ page 71.

Each deployed airbag is filled with gas. When this occurs, the airbag covers open and the airbags unfold with great force into the deployment zone within milliseconds. Inflated airbags reduce the movement of persons in the vehicle who are wearing safety belts in the direction of the impact and thus help to reduce the risk of injury. They can help to protect the head, upper body, and lap, for example. However, there is the possibility that airbag deployment can cause injuries.

The airbag system only works when the ignition is turned on.

If you or other passengers in the vehicle have physical limitations that prevent sitting in a correct position, modifications to the vehicle may be necessary. For more information, contact an authorized Audi dealer or authorized Audi Service Facility, or call Audi customer support at 1-800-822-2834.

Tips

The side curtain airbags in your vehicle have ejection mitigation functions. This reduces the risk of being ejected from the vehicle interior during an accident, especially in the event of a vehicle rollover.

Advanced airbag system



Fig. 63 Headliner: indicator light to display the status of the front passenger's airbag



The Advanced Airbag System in your vehicle has been certified to comply with the requirements of the United States Federal Motor Vehicle Safety

Standard (FMVSS) 208, as well as Canada Motor Vehicle Safety Standard (CMVSS) 208 as applicable at the time your vehicle was manufactured. According to these requirements, the front Advanced Airbag System on the passenger's side has been certified for "suppression" for infants approximately 12 months old and younger, and for "low risk deployment" for children aged 3 to 6 years old (as defined in the standard).

The advanced airbag system will activate or deactivate the front passenger's airbag based on the occupancy of the seat. If a front airbag deploys during a collision, the deployment force will adapt to the person in the vehicle.

Components

The advanced airbag system consists of the following components:

- Front airbags in the steering wheel and in the instrument panel on the front passenger's side: these can protect persons in the front seats during a collision
- Passenger occupant detection sensor in the front passenger's seat: this detects if the front passenger's seat is occupied (for example, by a person or a small child in a child safety seat)
- Seat position sensors on the front seats: these determine the distance between the seat and the steering wheel or instrument panel
- Sensors in the front safety belt latch: these detect if the safety belts are fastened
- PASSENGER AIR BAG OFF  ON  indicator light in the headliner: this indicates if the front passenger's airbag is activated or deactivated
-  Indicator light in the instrument cluster: this monitors the function of the Advanced Airbag System components to ensure they are functioning correctly

How the components function together

The passenger occupant detection sensor in the front passenger's seat detects if the front passenger's seat is occupied. The passenger occupant detection sensor measures the electrical capacity on the front passenger's seat. The passenger's airbag is activated or deactivated



depending on the electrical capacity that is measured.

The passenger's airbag is activated if:

- The electrical capacity is higher than the threshold stored in the control module
- The electrical capacity is the same as or greater than the electrical capacity of a typical adult



The passenger's airbag is deactivated if:



- The electrical capacity is lower than the threshold stored in the control module
- The electrical capacity is the same as or less than the electrical capacity of a typical one-year-old child in a child safety seat that has been used for certification in accordance with FMVSS 208



If the front passenger's airbag is activated, the PASSENGER AIR BAG ON  indicator light will turn on. If the front passenger's airbag is deactivated, the PASSENGER AIR BAG OFF  indicator light will turn on.

The deployment force of the front airbags adapts based on whether or not the safety belt is used and the distance between the seat and the steering wheel/instrument panel. For example, if a person is too close to the front airbag, the front airbag will deploy with less force to help reduce the risk of injury.

Meaning of PASSENGER AIR BAG OFF ON indicator light





When the ignition is switched on, the system detects whether the front passenger's seat is occupied. PASSENGER AIR BAG OFF  ON  will turn on for several seconds during this process. Then it will indicate whether the front passenger's airbag is activated or deactivated.

- PASSENGER AIR BAG OFF : the front passenger's airbag is deactivated and will not deploy in the event of an accident.
- PASSENGER AIR BAG ON : the front passenger's airbag is activated and could deploy in the event of an accident.



If a change to the occupancy status of the front passenger's seat is detected PASSENGER AIR BAG OFF  ON  will

flash for several seconds and will then display the status of the front passenger's airbag.



Always make sure the indicator light corresponds to the occupancy of the front passenger's seat.

- **An adult or individual of similar size in the front passenger's seat:** the front passenger's airbag must be activated, i.e. PASSENGER AIR BAG ON  must turn on for a specific period of time and then go out.
- **An individual of smaller size (for example, an adolescent or small adult) in the front passenger's seat:** the front passenger's airbag must be activated, i.e. PASSENGER AIR BAG ON  must turn on for a specific period of time and then go out.
- **Child in a child safety seat on the front passenger's seat:** the front passenger's airbag must be deactivated, so PASSENGER AIR BAG OFF  must stay on.
- **Front passenger's seat not occupied:** the front passenger's airbag must be deactivated, so PASSENGER AIR BAG OFF  must stay on.

WARNING

- An adult or a person with a small stature (such as a young person or small adult) seated on the front passenger's seat will not be protected by the passenger's airbag in the event of a collision if the passenger's airbag is deactivated. This increases the risk of injury and death. When the vehicle is in motion, always make sure that PASSENGER AIR BAG ON  turns on for a specific period of time and then goes out. If PASSENGER AIR BAG ON  does not turn on, make sure the front passenger is sitting correctly in the seat \Rightarrow page 60 and that there is nothing covering the front passenger's seat (such as blankets or pillows). If PASSENGER AIR BAG ON  still does not turn on, the front passenger's seat must not be used. Drive to an authorized Audi dealer or authorized Audi Service Facility and have the airbag system inspected.
- A child in a child safety seat on the front passenger's seat - especially in a rear-facing

child safety seat - can receive a severe impact if the front passenger's airbag deploys, which increases the risk of serious or fatal injury. Always secure child safety seats on the rear seats. If special circumstances require the use of a child safety seat on the front passenger's seat, always make sure that **PASSENGER AIR BAG OFF**  stays on while driving. If

PASSENGER AIR BAG OFF  does not turn on, remove the child safety seat and install it again according to the child safety seat manufacturer instructions. If **PASSENGER AIR BAG OFF**  still does not turn on, the front passenger's seat must not be used. Drive to an authorized Audi dealer or authorized Audi Service Facility and have the airbag system inspected.

- Fluids, electronic devices, or mechanical damage on the front passenger's seat may cause the front passenger seat occupant detection to malfunction. The system may then incorrectly detect if the front passenger's seat is occupied. As a result, it could deploy the front passenger's airbag incorrectly or fail to deploy it, which increases the risk of serious or fatal injury. Make sure that no wet objects (such as a wet hand towel) and no fluids come into contact with the front passenger's seat cushion. If the front passenger's seat becomes wet, dry it immediately. Make sure no electronic devices (such as a laptop or a retrofitted seat heater) are on the front passenger's seat. Do not transport any objects on or under the front passenger's seat.
- Seat covers or protective covers may prevent the advanced airbag system from correctly detecting child safety seats or persons in the front passenger's seat. You must not use seat covers or protective covers on the front passenger's seat that are not specifically approved for use on Audi seats with an advanced airbag system.

Child safety seats

General information

When installing and using child safety seats, follow the information in this Owner's Manual, the applicable state and federal regulations, and the manufacturer instructions for the child safety seat.

You can also obtain useful and current information from the following sources:

U.S. National Highway Traffic Safety Administration

<http://www.nhtsa.gov>

<http://www.safercar.gov>

National SAFE KIDS Campaign

<http://www.safekids.org>

SafetyBeltSafe U.S.A.

<http://www.carseat.org>

Transport Canada Information Centre

<http://www.tc.gc.ca/roadsafety>

Audi Customer Experience Center

<https://www.audiusa.com/help/contact-us>

<https://www.audi.ca/ca/web/en/models/layer/contact.html>





WARNING

To reduce the risk of serious or fatal injuries, children must always be secured in the vehicle with a child safety seat that is appropriate for their body size, weight, and age.

- Children ages 12 and under must be transported using the appropriate child safety seat. Note differences in regulations between states and countries.
- Child safety seats secured incorrectly in the vehicle may cause serious or fatal injuries in the event of an accident. Always secure the child safety seat according to the manufacturer instructions.
- Children or babies must not under any circumstances be held on the lap of the driver or other passengers while driving.
- Do not secure more than one child in a child safety seat.

- Never allow a child to sit in a child safety seat unsupervised.
- Never allow children to ride unsecured in the vehicle or to stand or kneel on the seats while driving. In the event of an accident, a child could be propelled through the vehicle. This can result in serious or fatal injuries to the child and passengers.
- If children use an incorrect seating position while driving, they have a higher risk of injury during a sudden braking maneuver or accident. This especially applies to children in the front passenger's seat or children who have their head near the side airbag deployment area, if the airbag system is deployed during an accident. This incorrect seating position can cause severe or even fatal injuries.
- Make sure there is enough space in front of the child in the child safety seat. If necessary, adjust the angle and position of the seat in front of the child safety seat.
- The rear side of a forward-facing child safety seat should be positioned as close as possible to the backrest on the vehicle seat. If the head restraints make it difficult to install a child safety seat, adjust or remove them if necessary ⇒ *page 63*. Reinstall the head restraints immediately once the child safety seat has been removed.
- Always make sure that the backrest on the seat where the child safety seat is installed is securely locked in place and cannot move forward. Otherwise, the backrest where the child safety seat is secured could move forward in the event of an accident or other emergency situation.
- NEVER use a rear-facing child safety seat on a seat with an ACTIVATED FRONT AIRBAG; this could cause DEATH or SERIOUS INJURIES to a CHILD.
 - Always secure child safety seats on the rear seats. If exceptional circumstances require the child safety seat to be placed on the front passenger's seat, then the front passenger's airbag must be deactivated. Always make sure that PASSENGER AIR BAG OFF  stays on

while driving. If

PASSENGER AIR BAG OFF  does not turn on, remove the child safety seat and install it again according to the child safety seat manufacturer instructions. If PASSENGER AIR BAG OFF  still does not turn on, the front passenger's seat must not be used. Drive to an authorized Audi dealer or authorized Audi Service Facility and have the airbag system inspected.

- If you must use a forward-facing child safety seat on the front passenger's seat, move the seat as far back as possible so that it is as far as possible from the front passenger's airbag. While doing this, make sure the seat can be adjusted all the way. A child in a child safety seat on the front passenger's seat can receive a severe impact if the front passenger's airbag deploys, which increases the risk of serious or fatal injury.
- Replace the child safety seat after an accident because there could be damage that is not visible.
- Even if a child is not sitting in the child safety seat, the child safety seat must be secured. An unsecured child safety seat may be thrown through the vehicle interior during sudden braking maneuvers or an accident.

Correct positioning for children

Always secure children in a child safety seat designed for the body size, weight, and age of the child.

You can secure child safety seats in your vehicle using the lower LATCH anchors or the safety belts. You can also secure child safety seats to the top tether anchor. Depending on the child safety seat, it may also be necessary to secure it to the top tether anchor. In Canada, securing forward-facing child safety seats to the top tether anchors is required by law.

Always transport children in the rear seats

Accident statistics show that children that are secured correctly in the rear seats are safer than in ►

front seats. Always transport children in suitable child safety seats secured on the rear seats.

In exceptional circumstances: transporting children in the front passenger's seat

If exceptional circumstances require the child safety seat to be placed on the front passenger's seat, then the front passenger's airbag must be deactivated. Please note the important information for this ⇒ *page 71, Advanced airbag system*. If you must secure a forward-facing child safety seat, move the front passenger's seat as far back as possible so that it is as far as possible from the front passenger's airbag. While doing this, make sure the seat can be adjusted all the way.

Only switch to a larger child safety seat when absolutely necessary

Switch to a larger child safety seat only when absolutely necessary. Secure your child using a safety belt without a child safety seat only if all of the following statements are true:

- The child is large enough to sit upright in the seat
- The child is able to sit with their back resting completely on the seat backrest
- The child is able to sit with their knees angled over the edge of the seat surface
- The child is able to sit with both of their feet completely touching the floor in the footwell
- The lap portion of the safety belt lies flat and securely over the hip area and never over the stomach
- The shoulder portion of the safety belt lies flat and securely over the center of the shoulder and the chest, and never under the arm, behind the back, or over the neck or face.
- The child is able to maintain this seating position throughout the entire trip

Read and follow the important information and warnings regarding the correct use of safety belts ⇒ *page 65*.

i Tips

- Child safety seats can also be secured to seats with side airbags. In the event of an accident, children can also be protected by

the side airbags if the child is correctly secured in a suitable child safety seat that is attached correctly.

- The lower LATCH anchors as well as the safety belt may be required to correctly install some child safety seats. Using both at the same time is permitted, provided that the fastening systems or safety belts do not impair those in an adjacent seating position.
- All child safety seats are constructed so that they can be secured using the lap safety belt in the vehicle.
- Child safety seats with a load leg can only be secured to the outer rear seats and to the front passenger's seat.

Securing child safety seats to the lower LATCH anchors



Fig. 64 Rear bench seat: lower LATCH anchors

Observe the safety precautions ⇒ *page 73*.

In the United States and Canada, child safety seats can be secured without safety belts using the LATCH system. LATCH stands for Lower Anchors and Tethers for Children. In Canada, similar systems are called UCRA, LUAS, or UAS.

The lower LATCH anchors in your vehicle are located on the outer seats of the rear bench seat between the seat surface and the backrest. These seating locations each have two lower LATCH anchors that can be used to secure a LATCH child safety seat. Marking points with a ⇒ *fig. 64* symbol are located on the covers for the lower LATCH anchors. You can locate the LATCH anchors using the marking points.

- ▶ Activate the child safety lock ⇒ *page 43*.

- ▶ Remove the cover* from both lower LATCH anchors.
- ▶ If you secure a child safety seat to the rear seat, secure any unused safety belts that are within reach of the child ⇒  in *Securing child safety seats with a safety belt* on page 77.
- ▶ Secure the child safety seat according to the child safety seat manufacturer instructions.
- ▶ Pull on the child safety seat to check if both sides are engaged correctly in the LATCH anchors.
- ▶ If possible, also secure the child safety seat to the respective top tether anchor in the vehicle ⇒ page 77.

WARNING

The LATCH anchors in the vehicle are only designed for child safety seats with the LATCH system. To reduce the risk of serious or fatal injury, never secure other child restraint systems, belts, or objects to the anchors.

Tips

The LATCH anchors are designed for a total weight (child and child safety seat combined) up to 65 lbs (29 kg). If the total weight is greater than this, the child safety seat must be secured with the vehicle safety belt.

Securing child safety seats with a safety belt

Observe the safety precautions ⇒ page 73. The front passenger's seat is a dangerous location for a child, even with an advanced airbag system. If exceptional circumstances require the child safety seat to be placed on the front passenger's seat, then the front passenger's airbag must be deactivated. Please note the important information for this ⇒ page 74, *Correct positioning for children* and ⇒ page 71, *Advanced airbag system*.

Securing child safety seats

- ▶ Activate the child safety lock ⇒ page 43.
- ▶ If you secure a child safety seat to the rear seat, secure any unused safety belts that are within reach of the child ⇒ , ⇒ page 77.

- ▶ If you secure a child safety seat to the front passenger's seat, adjust the front passenger's seat to the highest position.
- ▶ Secure the child safety seat according to the child safety seat manufacturer instructions.
- ▶ If necessary, activate the belt retractor lock ⇒ page 76.
- ▶ If the child safety seat is secured on the front passenger's seat, adjust the front passenger's seat backrest until it rests flat against the child safety seat. Also make sure that the upper safety belt fixture is behind the child safety seat.
- ▶ If you secure a child safety seat on the rear seat, also secure it to the correct top tether anchor if possible ⇒ page 77.

Activating the belt retractor lock

If you secure a child safety seat using the vehicle safety belt, you must activate the belt retractor lock. Follow the child safety seat manufacturer instructions.

The belt retractor lock prevents the safety belt from becoming loose while driving, which could result in the child safety seat no longer being adequately secured.

- ▶ Secure the child safety seat according to the child safety seat manufacturer instructions. While doing so, pull out the safety belt. Insert the safety belt into the belt latch that belongs to that seat until it audibly locks.
- ▶ Pull the upper belt out completely and then allow it to retract. You will hear a clicking sound while the belt is retracting. It will not be possible to pull the safety belt out any farther.
- ▶ Push the child safety seat into the seat and allow the belt to retract more.
- ▶ Make sure that the child safety seat cannot move more than 1 inch (2.5 cm).

Deactivating the belt retractor lock

- ▶ Unbuckle the safety belt from the belt latch.
- ▶ Remove the child safety seat according to the manufacturer instructions.
- ▶ Allow the safety belt to retract completely. The belt retractor lock is deactivated. ▶

! WARNING

- A safety belt that is not locked by the belt retractor lock or a locking device cannot secure a child safety seat while driving or in the event of an accident, which increases the risk of fatal injury. Always make sure the belt retractor lock on the safety belt is activated if the child safety seat manufacturer instructions require it.
- Due to the risk of fatal injury, never place a rear-facing child safety seat on the front passenger's seat when the front passenger's airbag is switched on.
- For the child safety seat to offer the maximum protection, it is especially important to route the vehicle safety belt correctly. Always follow the instructions from the child safety seat manufacturer for routing the safety belt correctly. Incorrectly fastened safety belts can cause injuries, even during minor accidents.

Additionally securing a child safety seat to the top tether anchor

Fig. 65 Rear backrest: top tether anchors to secure a child safety seat with an upper belt



Fig. 66 Rear backrest: securing the upper belt to the top tether anchor

Observe the safety precautions ⇨ *page 73*.

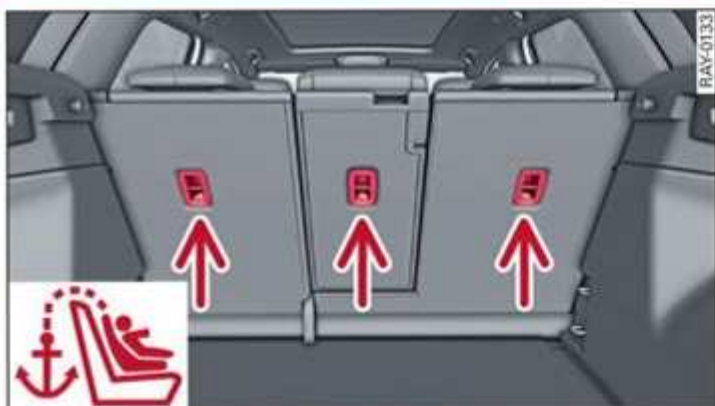
There is a top tether anchor behind every seat in the rear bench seat to additionally secure a child safety seat with an upper belt.

- ▶ Move the head restraint behind the child safety seat upward.
- ▶ Guide the upper belt on the child safety seat under the head restraint or along both sides of it and toward the rear (depending on the child safety seat model).
- ▶ Fasten the belt to the top tether anchor ⇨ *fig. 66*. While doing this, make sure the belt is not twisted and is not running over any sharp edges.
- ▶ Secure the child safety seat according to the child safety seat manufacturer instructions.
- ▶ Pull the belt tightly so that the child safety seat rests at the top of the seat backrest.
- ▶ If necessary, move the head restraint behind the child safety seat downward.

! WARNING

The top tether anchors in the vehicle are only designed for child safety seats equipped with an upper strap. To reduce the risk of serious or fatal injury, never secure other child restraint systems, belts, or objects to the anchors.

Securing unused safety belts on the rear bench seat

Fig. 67 Rear bench seat: securing unused safety belts

If a child safety seat is used on the rear bench seat, the child must not be able to reach any safety belts that are not being used. Secure safety belts that are within reach of the child. ▶

- ▶ If you secure a child safety seat to the LATCH anchors, fasten the safety belt on the seat where the child safety seat is installed using the seat's safety belt latch.
- ▶ If you secure a child safety seat to one of the outer seats, fasten the safety belt for the center seat in its latch.
- ▶ Activate the belt retractor lock on the fastened safety belts. To do this, pull the upper belt out completely and then allow it to retract. You will hear a clicking sound while the belt is retracting. It will not be possible to pull the safety belt out any farther.
- ▶ Make sure the fastened safety belt does not block access to the LATCH anchors. Otherwise, it may not be possible to secure the child safety seat to the LATCH anchors correctly.



WARNING

A child in a child safety seat could play with the unused safety belts and then become entangled in them, which increases the risk of fatal injury. Always secure unused safety belts so that they are not within reach of children in child safety seats.

Storage and convenience

Power sources

When the ignition is switched on, you may be able to use multiple power sources for external devices, depending on the vehicle equipment.



12 volt sockets

You can connect electrical accessories to the 12 volt sockets. The power usage from the sockets must not exceed a total of 120 watts. Do not connect multiple devices to the sockets in the vehicle at the same time.

The 12 volt sockets are labeled with the 12V symbol. They are located in the front center console, in the rear* and on the side trim panel in the luggage compartment*.

USB ports

Applies to: vehicles with USB ports

You can charge mobile devices using the USB ports. Depending on the vehicle, the USB ports may be labeled with one of the following symbols: , , or CHARGE ONLY.

WARNING

- To reduce the risk of fatal injury, store all connected devices securely when driving so that they do not move around inside the vehicle when braking or in the event of an accident.
- Incorrect usage can lead to serious injuries or burns. To reduce the risk of injuries, never leave children unattended in the vehicle with the vehicle key.

Note

- Read the operating manuals for the connected devices.
- To reduce the risk of damage to the vehicle electrical system, never attempt to charge the vehicle battery by connecting accessories that provide power to the power sources.
- Do not connect any device whose network class (voltage) does not match the network class designed for the socket.

- Disconnect the connectors from the power sources carefully to reduce the risk of damaging them.

Tips

Do not connect any other devices to the sockets when using the compressor* provided by the factory ⇨ *page 268*. The power consumption in the sockets may be temporarily exceeded when using the compressor*.

Cup holders

Applies to: vehicles with cup holders



Fig. 68 Front center console: cup holder

Depending on vehicle equipment, your vehicle may have cup holders in the front center console and in the rear center armrest, as well as bottle holders in the door panels.

Cup holders in the front center console

- Set your beverage in the holder ①.

Cup holders in the rear center armrest*

- To use the cup holder, fold the center armrest* down.

WARNING

- Do not put any hot beverages in the cup holder while the vehicle is moving. Hot beverages could spill, which increases the risk of injury.
- Do not use any breakable beverage containers (for example, made out of glass or porcelain). You could be injured by them in the event of an accident.

Note

Beverage containers in the cup holders should always have a lid. Otherwise, the liquid inside could spill and cause damage to vehicle equipment.

Storage and compartments

Additional storage compartments

Depending on vehicle equipment, there are a variety of storage areas, compartments, and retainers, such as the glove compartment, for safely storing and securing objects.

WARNING

- To reduce the risk of injury, make sure all storage compartments are always closed while driving.
- Loose objects can be thrown around the vehicle interior during sudden driving or braking maneuvers, which increases the risk of an accident. Store objects securely while driving.
- Only use the storage compartments in the door trim panels to store small objects that will not stick out of the compartment and impair the function of the side airbags.
- Only lightweight clothing should be hung from the garment hooks in the vehicle. Do not use clothes hangers to hang clothing. The pockets of the clothing must not contain any heavy, breakable, or sharp-edged objects. This could impair the effectiveness of the side curtain airbags.
- Make sure your view toward the rear is not blocked, for example by hanging clothing or objects in the vehicle.

Luggage compartment

General information

All pieces of luggage or objects must be securely fastened in the luggage compartment. Note the following to maintain good vehicle handling:

- ▶ Distribute the load evenly in the luggage compartment.
- ▶ Stow heavy luggage as far forward in the luggage compartment as possible.
- ▶ Use non-elastic cords attached to the tie-downs to secure objects.

WARNING

- Applies to: vehicles with luggage compartment cover: The luggage compartment cover is not a surface for storing objects. Objects placed on the cover increase the risk of injury to all vehicle occupants during sudden driving or braking maneuvers or in the event of a collision.
- Applies to: vehicles with luggage compartment cover: The luggage compartment cover must always be securely fastened when in use to reduce the risk of an accident.
- Loose objects can be thrown around the vehicle interior during sudden driving or braking maneuvers, which increases the risk of an accident. Always stow objects securely in the luggage compartment and secure them at the tie-downs. Use straps suitable for heavy objects.
- If pieces of luggage or objects are secured to the tie-downs with unsuitable or damaged straps, this can increase the risk of injury during braking maneuvers or accidents.
- When transporting heavy objects, the vehicle characteristics will change due to the shift in the center of gravity, which increases the risk of an accident. You may need to adapt your driving style and speed to the current conditions.
- Never exceed the permitted axle and load and vehicle weight ⇨ *page 290*.
- Never secure a child safety seat to the tie-downs.
- Never leave your vehicle unattended, especially if the luggage compartment lid is open. Children could enter the luggage compartment and close the luggage compartment lid from the inside. This creates the risk of fatal injury, since the children would be locked inside and may not be able to escape by themselves.

- Do not allow children to play in or on the vehicle. Close and lock the luggage compartment lid as well as all other doors when you leave the vehicle.
- Never transport persons in the luggage compartment. Each person in the vehicle must be secured correctly in the vehicle using the safety belts ⇒ *page 65*.
- Be careful when releasing the backrest and folding it forward. To reduce the risk of being pinched, pay attention and check when folding backrests forward.
- The backrest must be securely latched so objects cannot slide forward out of the luggage compartment during sudden braking.
- The backrest must be latched securely to ensure that the safety belt is protecting the center seating position.
- Always pull forward on the backrest to make sure it is correctly locked in place.
- If the safety belt becomes caught when folding the backrest back, then fold the backrest forward again and release the safety belt. Hold the safety belt with one hand and fold the backrest back carefully.
- For stability reasons, the bag hooks* can hold a maximum weight of 6.6 lbs (3 kg). Heavier objects are not adequately secured. There is risk of personal injury.

! Note

- To reduce the risk of damage, move the rear head restraints down ⇒ *page 64* before folding the rear backrests forward.
- When folding the backrest forward, make sure the outer safety belts are in the belt guide recess so that they do not get pinched in the backrest lock and damaged. Other objects should be removed from the rear bench seat to protect the backrest from damage.
- If you move the front seat back when the rear seat backrest is folded forward, you could damage the head restraints on the rear seat.
- Make sure that the heating grid strips for the rear window defogger are not damaged by abrasive objects.

i Tips

- The tire pressure must be adapted to the load ⇒ *page 252*.
- You can purchase straps at specialty stores.

Luggage compartment cover

Applies to: vehicles with luggage compartment cover



Fig. 69 Luggage compartment: removing and installing the luggage compartment cover

Observe the safety precautions ⇒ *page 80*.

- ▶ To remove the luggage compartment cover, unhook the straps ①.
- ▶ Press the luggage compartment cover down out of the retainers in the direction of the arrow ②.
- ▶ Remove the cover in the direction of the arrow ③.
- ▶ To install the luggage compartment cover, place the cover loosely on the retainers.
- ▶ Press the left and right sides of the luggage compartment cover onto the retainers.
- ▶ Hook the straps ① into the luggage compartment lid.

i Tips

Depending on the vehicle equipment, you may be able to store the luggage compartment cover under the adjustable cargo floor ⇒ *page 82*. Remove the side inserts to do this.

Folding the outer backrests

Applies to: vehicles with folding backrests

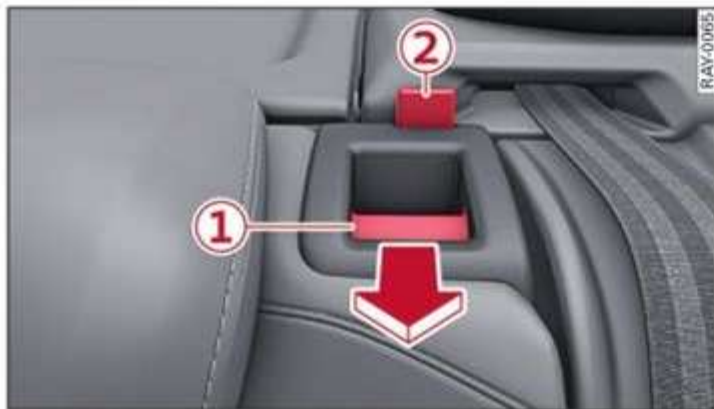

Fig. 70 Outer backrest: release lever and latching indicator with red marking

Depending on the vehicle equipment, it may be possible to fold the backrests forward separately or together.

Observe the safety precautions ⇒ page 80.

Folding the outer rear backrests forward and backward

- ▶ Pull the release lever ① in the direction of the arrow and fold the backrest forward.
- ▶ After the transport, fold the backrest up again until it latches and the red marking ② is no longer visible.

Folding the center armrest

Applies to: vehicles with folding center armrest

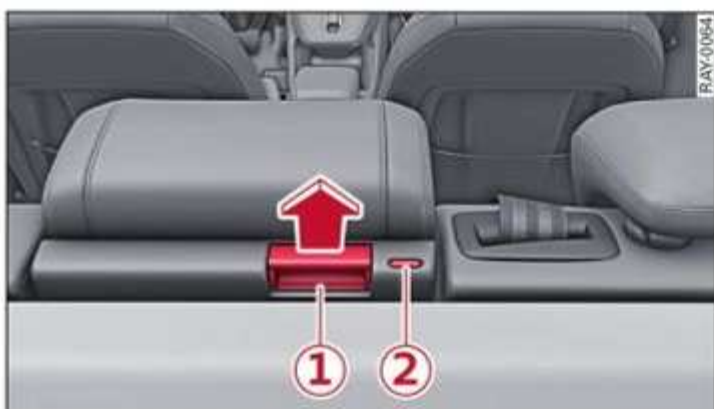

Fig. 71 Center backrest: release lever and latching indicator with red marking

Observe the safety precautions ⇒ page 80.

Folding the center rear backrest forward and backward

- ▶ Pull the release lever ① in the direction of the arrow and fold the backrest forward.

- ▶ Fold the backrest back up again until it latches securely and the red marking on the latching indicator ② is no longer visible.

Tie-downs



Fig. 72 Luggage compartment: location of the tie-downs

Observe the safety precautions ⇒ page 80.

Tie-downs

There are tie-downs ① in the luggage compartment to secure pieces of luggage and objects.

- ▶ Use the tie-downs to secure the cargo.

Cargo floor

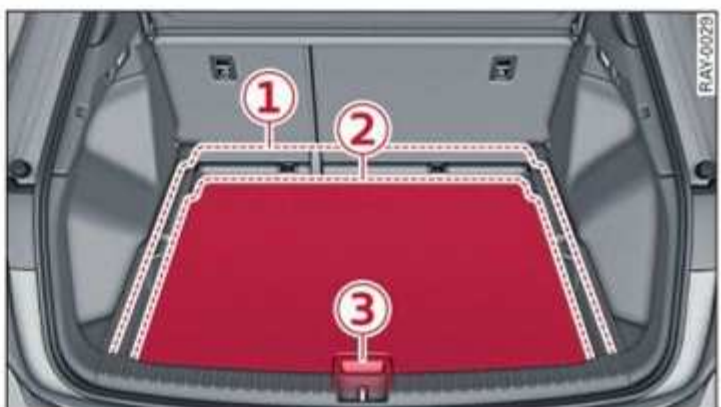

Fig. 73 Luggage compartment: lowering/raising the cargo floor*

Removing and installing the cargo floor

- ▶ To remove the cargo floor, lift it by the handle ③.
- ▶ Pull the cargo floor toward the vehicle rear, out of the luggage compartment.
- ▶ To insert the cargo floor, push it all the way toward the backrest.

Lowering/raising the cargo floor

Applies to: vehicles with adjustable cargo floor

The height of the cargo floor can be adjusted to create more space in the luggage compartment or to make loading and unloading easier.

- ▶ To lower the cargo floor, lift it at the handle ③.
- ▶ Pull the cargo floor toward you slightly and insert it in the lower position ②.
- ▶ To raise the cargo floor, remove it and reinsert it in the upper position ①.

Roof rack

General information

Applies to: vehicles with roof rack mount



Applies to: vehicles without roof rail
Fig. 74 Roof: mounting points

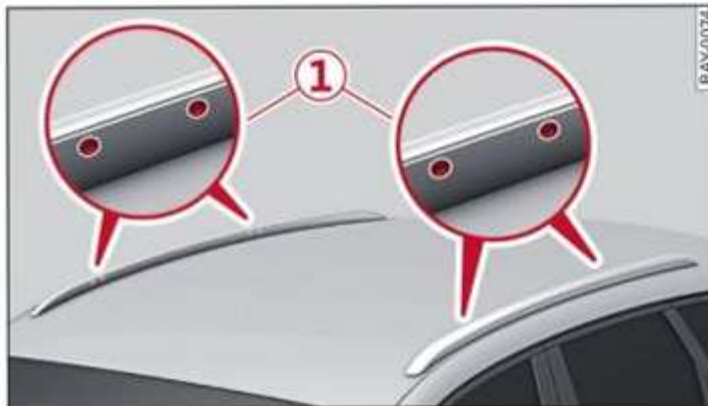

Applies to: vehicles with roof rail
Fig. 75 Roof rail: mounting points

If luggage or cargo is to be carried on the roof, you must observe the following:

- These roof racks are the basis for a complete roof rack system. Only roof racks that are suitable for your vehicle may be used. Audi recommends roof racks and attachments from the Audi Genuine Accessories program.
- Make sure the roof rack is mounted on the vehicle only at the specified locations ①.

- Note the permitted axle load, permitted total weight, and permitted roof load of your vehicle ⇒ page 290. The roof load is the total of the weight of the roof rack, the attachments and the cargo you are carrying. However, you must also note the permitted load of the carrier system being used.

⚠ WARNING

- Follow the installation instructions provided with the roof rack system. If you do not secure the roof rack system and objects on the roof correctly, they could come loose from the vehicle and cause an accident.
- The risk of an accident increases when using a roof rack system, because it changes the driving characteristics by shifting the center of gravity and/or the increasing the surface area exposed to wind. You may need to adapt your driving style and speed to the current conditions.

! Note

Make sure that the luggage compartment lid and the panoramic glass roof do not come into contact with objects on the roof when they are open.

🌱 For the sake of the environment

Energy usage will increase because of the increased wind resistance. Remove the roof rack when you are no longer using it.

Warm and cold

Climate control system

Description

Your vehicle has a deluxe automatic climate control system with three zones in which the temperature, air distribution, and air supply can be adjusted separately for the front left and right sides, as well as the temperature in the rear.

The climate control system warms, cools, dehumidifies, and filters the air in the vehicle interior. It is the most effective when the windows and, depending on vehicle equipment, the roof are closed. If there is a build-up of heat inside the vehicle, ventilation can help to speed up the cooling process.

The deluxe climate control system automatically maintains a temperature once it has been set. In all heating mode functions except defrost, the blower only switches to a higher speed once the heater has reached a certain temperature.

Active combination filter

When the fan is running, the filter will reduce particulate matter and the concentration of pollen, as well as odors in the interior.

i Tips

- To prevent interference with the heating or cooling output and to prevent the windows from fogging over, the air intake in front of the windshield must be free of ice, snow, and leaves.
- Condensation from the cooling system can drip and form a puddle of water under the vehicle. This is normal and does not mean there is a leak.
- The energy management system may temporarily switch off certain functions, such as the seat heating or rear window defogger. These systems will be available again once the energy supply has been restored.

Operating in the cockpit

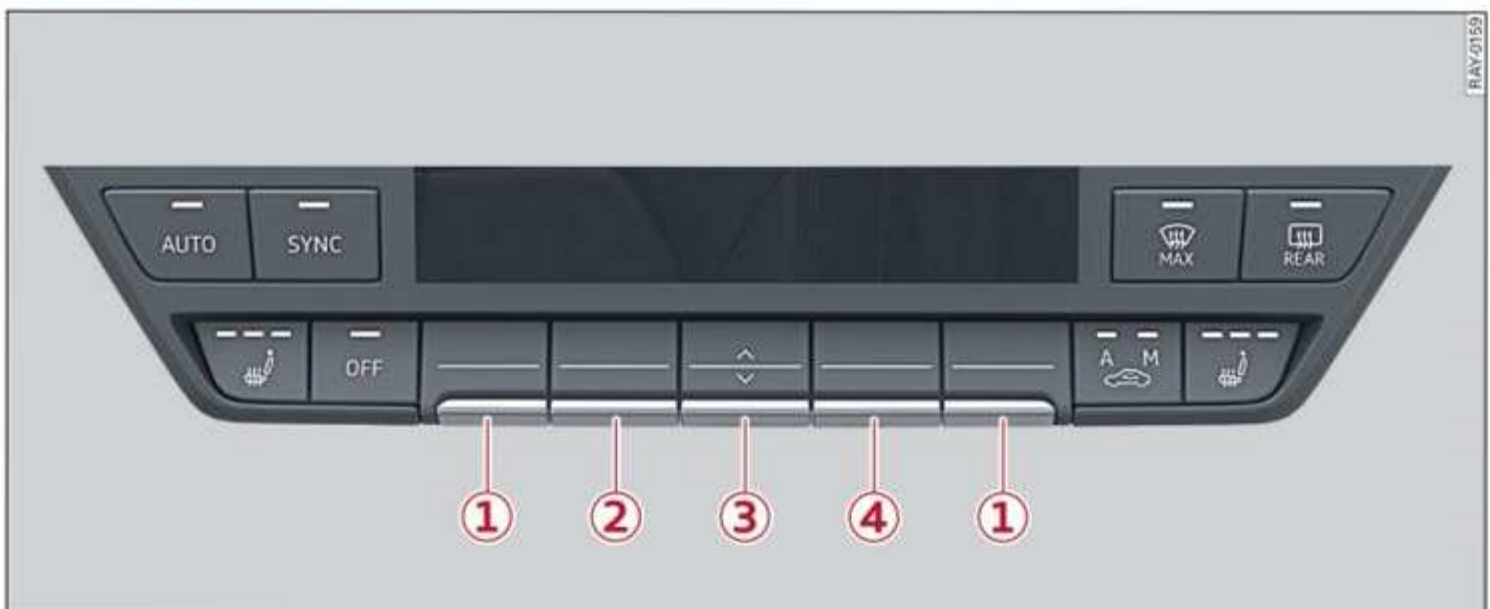

Fig. 76 Deluxe automatic climate control: controls

Observe the safety precautions ⇒ ⚠.

The functions can be switched on and off by pressing the buttons or adjusted using the rocker switches. The LED in a button will illuminate when the function is switched on.

OFF Switching the climate control system on/off

Pressing the **OFF** button switches the climate control system on and off. It also switches on when you press another button. Airflow from outside is blocked when the climate control system is switched off.

A/C Cooling mode

The cooling mode only functions with the blower turned on. The air is not cooled and humidity is not reduced when cooling mode is switched off. This can cause fog on the windows. The cooling mode switches off automatically at low outside temperatures.

You can select from the following settings for cooling mode by pressing the rocker switch **3**:

- **MAX**: activates the maximum cooling mode of the climate control system. To reduce unnecessary energy usage, only use this function briefly.
- **ON**: switches on the cooling mode and controls it automatically.
- **OFF**: switches off the cooling mode.

AUTO Automatic mode

Automatic mode maintains a constant temperature inside the vehicle. Air temperature, airflow and air distribution are controlled automatically. Automatic mode will switch off once a button that controls climate control functions is pressed.

Activating **AUTO** also switches automatic recirculation on.

Temperature

The temperature can be adjusted separately for the front seats by pressing the rocker switch **1**.

Temperatures between 60 °F (+16 °C) and 84 °F (+28 °C) can be set. If outside of this range, **LO** or **HI** will appear in the climate control system display. In both settings, the climate control runs constantly at the maximum cooling or heating level. The temperature is not regulated.

SYNC Synchronization

Pressing and holding the **SYNC** button transfers the temperature setting on the driver's side to the front passenger's side. Synchronization is switched off when the setting for the front passenger's side is changed.

Blower

The blower should always run at a low setting to prevent the windows from fogging and to ensure a continuous exchange of air inside the vehicle.

You can manually adjust the amount of air generated by the blower to your preference using the rocker switch **2**. To have the blower regulated automatically, press the **AUTO** button.



Air distribution

To prevent the side windows from fogging over, open the side air vents and angle them toward the side.

The air distribution can be adjusted using the rocker switch **4**. Press the rocker switch **4** repeatedly until the desired air distribution setting is displayed in the climate control system controls. To have the air distribution regulated automatically, press the **AUTO** button.

Defrosting

The windshield and side windows are defrosted or cleared of condensation as quickly as possible. The maximum amount of air flows mainly from the vents below the windshield.



Defrost is switched on and off using the  button. Recirculation mode switches off. The temperature should be set at 72 °F (+22 °C) or higher. The temperature is controlled automatically. Depending on the outside temperature, the A/C cooling mode may automatically switch on. Defrosting can be switched off by pressing the , **AUTO**, or  buttons, or the rocker switches **2** or **4**.



Applies to: vehicles with windshield defogger: The windshield defogger switches on automatically when outside temperatures are low. Depending on the outside temperature, you can switch on the windshield defogger manually by pressing the  button.

Recirculation mode

In recirculation mode, the air inside the vehicle is circulated and filtered. This prevents the unfiltered air outside the vehicle from entering the vehicle interior ⇒ .



Recirculation mode can be controlled manually or automatically:

- Switching on manual recirculation mode: press the  repeatedly until the LED above the letter **M** turns on.
- Switching on automatic recirculation mode: press the  repeatedly until the LED above the letter **A** turns on.

The recirculation mode can be changed by pressing the , **AUTO** or  button.

Rear window defogger



If the rear window defogger is activated while the ignition is switched on, the battery management system will determine if it is possible to switch it on based on the vehicle battery charge level. Otherwise, the rear window defogger will function when the drive system is switched on and will switch off automatically after 10 – 20 minutes, depending on the outside temperature.

Pressing the  button switches the rear window defogger on or off. To prevent the rear window defogger from switching off automatically, press and hold the  button for more than two seconds. Depending on the vehicle equipment, the exterior mirror heating may turn on automatically when the rear window defogger is switched on.

Vents

The center and outer vents in the cockpit can be opened and closed using the levers on the fins. You can also adjust the airflow from the vents using the levers.

Seat heating

The seat heating temperature can be set at various levels. Press the  button once to switch on the highest level . Press the  button again to decrease the temperature one level at a time.

The seat heating is off when all of the LEDs are off.

WARNING

- You should not leave the recirculation mode on for an extended period of time. This can cause the windows to fog, which increases the risk of an accident.
- Using recirculation mode or automatic recirculation for an extended period of time can cause the CO₂ concentration inside the vehicle to increase. This can have a negative effect on the well-being of vehicle occupants, which can increase the risk of an accident. Switch recirculation mode or automatic recirculation off and ventilate the vehicle at the first sign of unwellness.
- Individuals with reduced sensitivity to pain or temperature could develop burns when using the seat heating function. To reduce the risk of injury, these individuals should not use seat heating.

Note

To reduce the risk of damage to the seat heating elements, do not kneel on the seats or place heavy pressure on one area of the seat.

For the sake of the environment

Energy can be saved by switching off the A/C mode.

Tips

If the front passenger's seat heating is turned on, it will not turn on again automatically if more than 10 minutes have passed between switching the ignition off and switching it on again.

Operating in the rear

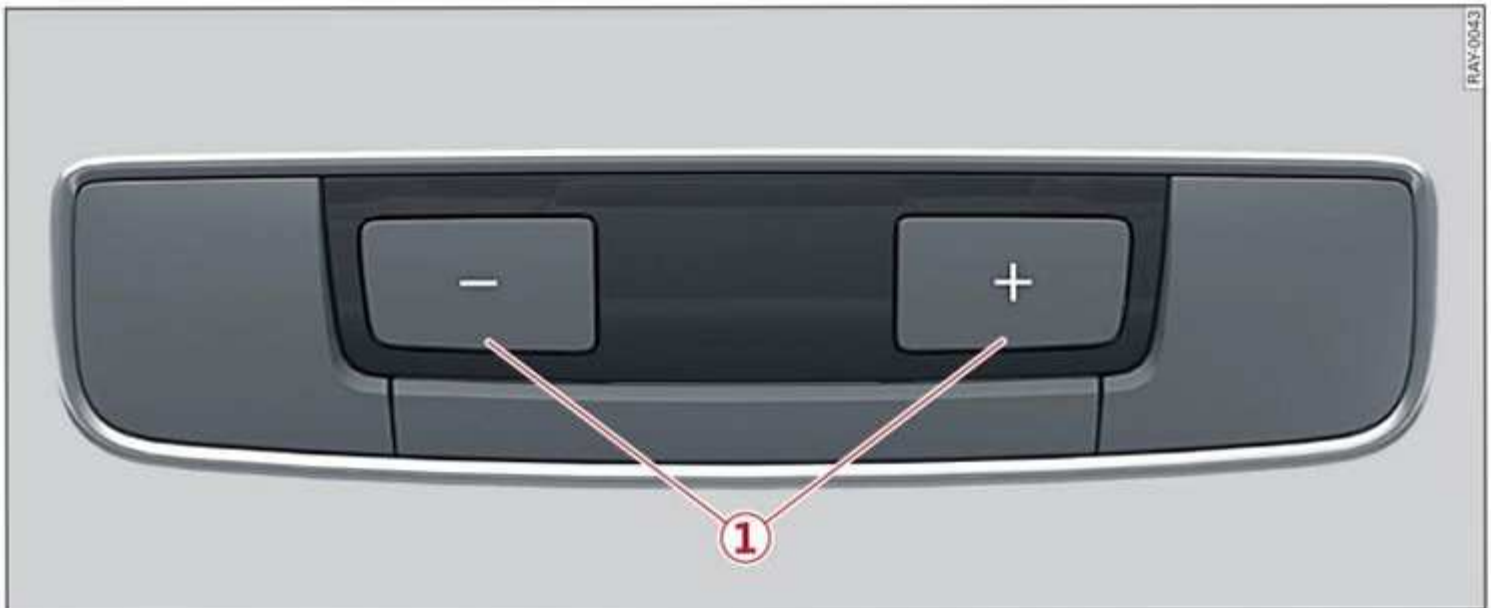

Fig. 77 Deluxe automatic climate control: controls

Floor vents are located under the front seats to provide climate control in the rear of the vehicle. In addition to the foot vents, there are adjustable vents located on the center armrest.

The temperature can be selected using the \square and \square buttons ①.

Additional settings

You can adjust additional settings.

- Applies to MMI: Select on the home screen: **VEHICLE** > **Air conditioning**.

Auto recirculation

When switched on, automatic recirculation controls the recirculation mode automatically \Rightarrow \triangle in *Operating in the cockpit on page 86*. You must press the ☞ button if fog forms on the windows.

Messages

The following messages may appear depending on the vehicle equipment:

A/C Air conditioner: CO2 concentration still increasing. Ventilate the vehicle. See owner's manual

Ventilate the vehicle immediately. If this message continues to display, stop driving as soon as you can safely park your vehicle and contact an authorized Audi dealer or authorized Audi Service

Facility. If this message appears, drive to an authorized Audi dealer or authorized Audi Service Facility immediately.

A/C Air conditioner: increase in CO2 concentration. Ventilate vehicle. See owner's manual

Ventilate the vehicle. If this message continues to display, stop driving as soon as you can safely park your vehicle and contact an authorized Audi dealer or authorized Audi Service Facility. If this message appears, drive to an authorized Audi dealer or authorized Audi Service Facility immediately.

Climate control limited

The battery cooling increases to prevent damage to the battery. This will limit the climate control.

Steering wheel heating

Switching on and off

Applies to: vehicles with steering wheel heating

- Press the ☞ button on the multifunction steering wheel to switch the steering wheel heating on and off.

Auxiliary climate control

Description

The auxiliary climate control system warms or cools the vehicle interior. This function can be used when the drive system is switched off.

You can control the auxiliary air conditioning in the MMI and using the myAudi app.

Operating requirements

The charge level of the high-voltage battery must be sufficient.

Tips

- Using the auxiliary climate control while charging can also reduce the charge level of the high-voltage battery.
- Starting or parking the vehicle will not switch off the auxiliary climate control automatically.
- The auxiliary climate control system will not turn on automatically or will turn off earlier if the high-voltage battery charge level is too low, even if the vehicle is being charged at the time.

Operation

Applies to: MMI: Select on the home screen: **VEHICLE > Air conditioning > Auxiliary air conditioning**.

Immediate start

You can immediately switch the auxiliary climate control on and off using the  button. When this function is switched on, a colored bar lights up over the button and the remaining time is displayed.

The auxiliary climate control will run for a maximum of 30 minutes after the immediate start.

Timer programming

You can set up and activate up to two timers for the departure time.

- ▶ Select a timer using **>**.
- ▶ Set the date and press **Next**.
- ▶ Set the time (departure time) and press **OK**.

- ▶ Set the second timer, if necessary.

By setting the departure time, you determine when your vehicle should reach the desired temperature. The departure time can be a maximum of six days in the future.

The auxiliary climate control will continue to run for approximately 15 minutes after reaching the departure time.

After switching off the ignition

Information about the active timer will appear in the display after switching off the ignition. You can start the set climate control settings immediately with the  button, or go to the auxiliary climate control menu with the **>** button.

Target temperature

You can adjust the target temperature for the climate control using the myAudi app.

Tips

- Make sure the time and date match in the system settings so that the timer can function correctly ⇒ *page 225*.
- The auxiliary climate control can also be switched on and off immediately when a timer is set.
- You can operate the climate control in the vehicle interior when the high-voltage battery is charging using the charging timer ⇒ *page 106*. The climate control output depends on the power supply capacity.

Additional settings

- ▶ Applies to: MMI: Select on the home screen: **VEHICLE > Air conditioning > Auxiliary air conditioning > **.

Start A/C after unlocking

If this function is activated, the climate control will continue to run for up to five minutes after the vehicle has been unlocked. This function will turn off when the vehicle is locked. ▶

Comfort aux. A/C

You can adjust if comfort heating functions, such as seat heating, should also be activated when auxiliary climate control is used. You can select the respective zones.

Window and mirror heating

You can set if the rear window and mirrors should also be heated during auxiliary climate control.

Tips

The comfort auxiliary climate control may be restricted during charging, depending on the charging method that is selected.

Messages

The following messages may appear depending on the vehicle equipment:





 **The auxiliary air conditioning is currently unavailable due to a malfunction.**



If this message appears, there is a system malfunction. Drive immediately to an authorized Audi dealer or authorized Audi Service Facility to have the malfunction repaired.

Fluids in the A/C system

Refrigerant in the A/C system

The sticker in the front compartment provides information about the type and amount of refrigerant used in the vehicle's climate control system. The sticker is located in the front section of the front compartment or at the front or back of the hood.

Symbol	Meaning
	Warning: the A/C system must only be serviced by qualified technicians.
	Refrigerant type
	Lubricant type
	Refer to the service information (only available for authorized Audi dealers or authorized Audi Service Facilities)

Symbol	Meaning
	The A/C system must only be serviced by qualified technicians.
	Flammable refrigerant
	Make sure all components are disposed of correctly and never install components in the vehicle that have been removed from old vehicles or taken from recycling.

Lubricant in the A/C system

The sticker in the front compartment provides information about the type of lubricant used in the vehicle climate control system. For the refrigerant oil quantity, refer to the Technical Data ⇨ page 289.

WARNING

- The climate control system may only be serviced by qualified and certified technicians who have been trained according to the country-specific standards, for example SAE standards J2845 and J2911.
- The refrigerant is flammable. Keep the vehicle away from open flames, sparks, and other ignition sources to reduce the risk of serious or fatal injuries.
 - The refrigerant is under pressure and can explode if heated, which increases the risk of serious or fatal injuries.
 - The refrigerant can create toxic vapors when it comes in contact with hot surfaces. Do not breathe in these vapors, due to risk of serious or fatal injuries.

Tips

- Never repair the A/C system evaporator with components from old vehicles or from recycling.
- New replacement evaporators for portable A/C systems must be certified and labeled as such, so that they comply with the SAE standard J2842 HF0-1234yf and R744.

Driving

Starting the vehicle

Convenience key

Applies to: vehicles with convenience key



Fig. 78 Center console: start drive system

Your vehicle is powered by electricity. Similar to a vehicle with a combustion engine, the ignition and drive system can be switched on separately. When only the ignition is switched on, electronic systems such as the MMI are available. However, the vehicle is not ready to drive. Electric power is able to move the vehicle once the drive system is switched on and becomes active.

Requirement: the key must be in the vehicle.

Switching the drive system on

- ▶ Press and hold the brake pedal.
- ▶ Select the “D” or “R” selector lever position.
The drive system will switch on.

The power meter indicates if the drive system is switched on ⇒ *page 16*.

Switching the drive system off

- ▶ Bring the vehicle to a full stop.
- ▶ Press the **START STOP** button. The drive system will switch off. The parking brake will be set.

You may also switch off the drive system by pressing the  ⇒ *page 92, fig. 79* button when the vehicle is stationary. In this case, the ignition will remain switched on.

Switching the drive system off in an emergency

If necessary in an emergency, the drive system can also be switched off while driving using the emergency off function*.

- ▶ Press the **START STOP** button twice in a row or press and hold it one time.

Switching on and off

The ignition will switch on automatically when you enter the vehicle with the key and press the brake pedal.

The ignition will switch off automatically when you set the parking brake and exit the vehicle.

Among other indicators, the system detects that you have left the vehicle based on the following factors:

- The driver's door has been opened.
- The driver's safety belt has been unbuckled.
- The brake pedal is not being pressed.
- The driver's seat is not occupied.

The ignition will also switch off 30 minutes after you exit the vehicle or if you lock the vehicle from the outside.

If you would like to switch the ignition on or off manually, follow these steps:

- Press the **START STOP** button while the vehicle is stationary without pressing the brake pedal.

WARNING

- Never switch off the drive system before the vehicle has come to a complete stop. Switching it off before the vehicle has stopped may impair the function of the brake booster and power steering. You would then need to use more force to steer and brake the vehicle. The fact that you cannot steer and brake as usual may increase the risk of accidents and serious injuries.
- Secure the vehicle against rolling before exiting the vehicle ⇒ *page 91*.

Tips

- Brief noises are normal when starting and parking the vehicle and are no cause for concern.
- It may not be possible to start the vehicle in extremely low temperatures.
- The drive power depends on the temperature and the charge level of the high-voltage battery.

Messages

The following messages may appear depending on the vehicle equipment:

Engine start system: malfunction! Please contact Service

There is a malfunction in the engine start system. Drive immediately to an authorized Audi dealer or authorized Audi Service Facility to have the malfunction repaired.

Remote control key: key not detected. Is the key still in the vehicle?

The vehicle key was removed from the vehicle while the drive system was switched on. If the vehicle key is no longer in the vehicle, you can no longer switch on the ignition or the drive system after switching off the drive system. You also cannot lock the vehicle from the outside.

Remote control key: hold back of key against the designated area. See owner's manual

The battery in the vehicle key may be drained or there may be a malfunction. To start the vehicle, you must also hold the vehicle key against the location shown  ⇒ page 90, fig. 78.

If the malfunction remains, drive immediately to an authorized Audi dealer or authorized Audi Service Facility to have the malfunction corrected.

When driving

Starting to drive, stopping, and parking

Starting from a stop

- ▶ Press and hold the brake pedal.
- ▶ Select the “D” or “R” selector lever position. The parking brake will be set automatically. The drive system switches on.
- ▶ Release the brake pedal. The vehicle may roll.
- ▶ Press the accelerator pedal to accelerate.

Securing the vehicle against rolling

Secure your vehicle to prevent it from rolling before exiting the vehicle.

- ▶ Set the parking brake.
- ▶ If parking on a steep road, turn the steering wheel so that your vehicle will roll against the curb in case it should start to move.

If one of these measures is not possible, for example because there is no vehicle power, you must secure your vehicle against rolling using additional measures.

- ▶ Only park the vehicle on a level surface.
- ▶ Use suitable objects to block the front and rear wheels.

Maintaining the vehicle's rolling ability

See ⇒ page 97.

WARNING

- Always set the parking brake when leaving your vehicle, even if for a short period of time. If the parking brake is not set, the vehicle could roll away, increasing the risk of an accident.
- Do not leave your vehicle unattended while the drive system is active, because this increases the risk of an accident.
- If the parking brake is set, it can release automatically when the accelerator pedal is pressed. To reduce the risk of an accident, never press the accelerator pedal without paying attention.
- If you leave the vehicle, switch the ignition off and take the key with you. This is especially important when leaving persons or

animals in the vehicle. Otherwise, the vehicle could start unintentionally, the parking brake could release, or electronic equipment could activate, which increases the risk of an accident.

- No persons or animals should be left in a locked vehicle. Locked doors make it more difficult for emergency workers to enter the vehicle, which puts lives at risk.
- If you do not begin driving immediately after releasing the brake pedal, your vehicle may begin to roll backward. Press the brake pedal or set the parking brake immediately.

! Note

If you have to stop on an incline, always press the brake pedal to hold the vehicle in place to reduce the risk of the vehicle rolling backward. Do not try to hold the vehicle in place by pressing and holding the accelerator pedal. The drive system can overheat, which increases the risk of damage.

Gears and driving programs

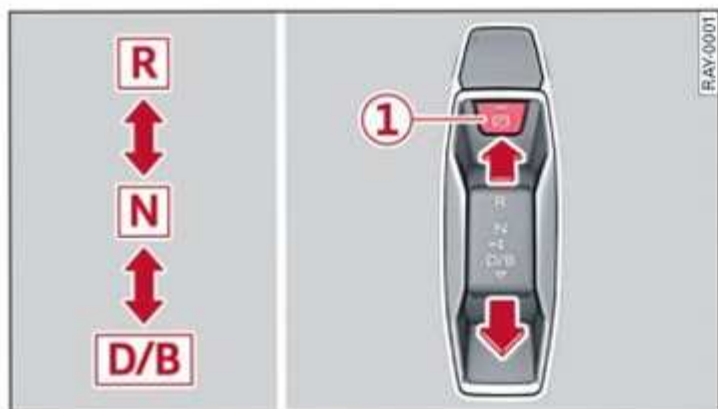

Fig. 79 Center console: selector lever

Gears

The selector lever positions are displayed on the selector lever.

- R (Reverse): driving in reverse
- N (Neutral): idle
- D (Drive): driving forward

Selecting a gear

Requirement: the key must be detected.

- Bring the vehicle to a full stop and press the brake pedal.

- To select the nearest position, move the selector lever forward or back until you feel the first pressure point.
- To skip a position (for example, to move from “D” directly to “R”), move the selector lever past the pressure point in the desired direction.
- The position that is selected will illuminate on the selector lever.

“N” (Neutral) selector lever position

In the “N” selector lever position, power is not transmitted to the driving wheels. Use the “N” selector lever position in situations such as a car wash (with conveyor belts) ⇒ page 97, *Enabling rolling ability (neutral)*.

If you unintentionally select “N” while driving (faster than 1 mph (2 km/h)), you can select “D” again without pressing the brake pedal.

“B” driving program

While driving in the “D” position, the “B” driving program can be selected for maximum recuperation ⇒ page 93.

To switch between the “D” and “B” driving programs, push the selector lever toward the rear.

! WARNING

- Before you begin driving, check if the label for the desired position is illuminated on the selector lever.
- Secure the vehicle against rolling before exiting the vehicle ⇒ page 91.
- To reduce the risk of an accident, do not press the accelerator pedal when changing selector lever positions while the vehicle is stationary and the drive system is switched on.
- Never select the “R” position while driving. Doing so could cause an accident.
- The vehicle can roll even if the ignition is switched off.

i Tips

- If you shift back and forth between “D” and “R” within one second, you do not need to press the brake pedal. This makes it possible to “rock” if it is stuck, for example.

– Audi recommends the “D” driving program for everyday driving.

Accelerator pedal

You can accelerate the vehicle using the accelerator pedal.

Maximum acceleration

If you press the accelerator pedal all the way down, the motor’s full power will be used and you will reach maximum acceleration, also called “kick-down”.



WARNING

The driving wheels could spin and the vehicle could swerve on slick or slippery road surfaces when using kick-down, which increases the risk of an accident.

Messages

The following messages may appear depending on the vehicle equipment:

Driver availability recognition not possible. See owner's manual

No selector lever position can be selected. Make sure the driver’s door is closed, the driver’s safety belt is fastened, and the driver’s seat is occupied.

Drive system

Breaking in

A new vehicle must be broken in within the first 2,000 miles (3,000 km) so that all moving parts work smoothly together, which helps to increase the service life of the drive system components. The energy use may be higher during this time.

Drive for longer stretches whenever possible during the break-in period, and use a moderate driving style.

Electric drive system

Vehicles with an electric drive system are powered by an electric motor. The drive power de-

pends on the temperature and the charge level of the high-voltage battery.

Recuperation

The vehicle is able to recover energy by using recuperation. The electric drive system operates like a generator and converts a large portion of kinetic energy into electrical energy that is stored in the high-voltage battery. The vehicle is braked during recuperation, which is similar to the engine braking effect on a vehicle with a combustion engine. Recuperation can activate when in the “D” driving program if you press the brake pedal or take your foot off the accelerator pedal.

When you press the brake pedal, recuperation is used to brake the vehicle. The brakes will only be activated if necessary. Driving with a moderate style makes it possible to brake almost to a stop using only recuperation.

Setting options



Depending on the equipment, you may be able to set how strongly the vehicle should be braked by recuperation while coasting.

► Applies to MMI: Select on the home screen: **VEHICLE > Efficiency assist > Recuperation**.

Automatic: the recuperation braking effect is adjusted proactively, for example based on the route ahead. If the vehicle is equipped with a front radar sensor, then the recuperation can also react to vehicles driving ahead. You can temporarily adjust the braking effect by selecting a recuperation level using the shift paddles*. As soon as you press the accelerator pedal, the vehicle will switch to adjust proactively again.

Off: the proactive recuperation will be switched off. You can adjust the braking effect by selecting a recuperation level using the shift paddles*. Vehicles without shift paddles will not be braked by recuperation while coasting.

Settings using the shift paddles*:

- Select  for a stronger braking effect.
- Select  for a weaker braking effect.

For maximum recuperation, you can select the “B” driving program ⇨ [page 92](#).

WARNING

In certain situations, the recuperation may brake proactively. However, the recuperation braking effect is limited. Always be ready to brake to reduce the risk of an accident.

Tips

If the ESC is limited or switched off, automatic recuperation is not available and will not brake.

Range mode

The range mode will switch the vehicle to a mode with less energy consumption to maximize the current range.

► Applies to MMI: Select on the home screen: **VEHICLE > Efficiency assist > Range mode**.

The drive system power and the maximum speed will be reduced. This can also turn off certain energy consumers. You can exit this mode either via the MMI, pressing the Audi drive select* button, or switching off the ignition.

Vehicle sound

The electric drive system generates considerably less noise than a combustion engine. An artificial engine sound is generated when driving electrically so that the vehicle can be heard from the outside when driving. The vehicle sound automatically fades out at higher speeds when the sounds from the tires and wind start increasing.

WARNING

Other road users may not be able to clearly hear electric vehicles when they are driving. This increases the risk of an accident particularly when driving in areas with little traffic, when maneuvering, or when driving in reverse.

Efficient and environmentally-conscious driving

Your driving style greatly influences the amount of fuel and energy consumed, the environmental

impact, and the wear on the motor, brakes, and tires. Note the following information for efficient and environmentally-conscious driving:

- Select the Audi drive select* **efficiency** mode.
- Turn off electrical equipment that is not needed, for example seat heating*.
- Anticipate upcoming traffic situations while driving to avoid unnecessary acceleration and braking.
- Avoid driving at high speeds.
- Avoid adding extra weight to the vehicle if possible, for example by not leaving roof racks or bike racks installed when they are not needed.
- Make sure the tire pressure is correct.
- Have maintenance performed regularly on the vehicle.
- Do not drive with winter tires during the summer.
- Avoid driving short distances when possible.
- Brake early and evenly to use recuperation.

Messages

The following messages may appear depending on the vehicle equipment:

Drive system: malfunction! Safely stop vehicle

There is a malfunction in the drive system. The brake booster and the power steering may stop working. Stop the vehicle immediately or as soon as possible and do not continue driving. Secure the vehicle against rolling before exiting the vehicle ⇒ *page 97*. Have the problem corrected by an authorized Audi dealer or authorized Audi Service Facility.

Drive system: warning! Vehicle limited to maneuvering! See owner's manual

The drive system power is not sufficient, for example because the temperature of the high-voltage battery or the charge level is too low. Only maneuvering at low speeds is possible. Certain electrical equipment is limited. If the charge level is low, charge the high-voltage battery. The indicator light will turn off once the driving power increases again. ►

If the message appears while driving, a breakdown in traffic may occur soon.

Drive system: malfunction! Please contact Service

There is a malfunction in the drive system. Drive slowly to an authorized Audi dealer or authorized Audi Service Facility to have the malfunction corrected.

Drive system: warning! Limited performance

The driving power is limited. The high-voltage battery may not be sufficiently charged or is at the operating temperature threshold, for example, when the outside temperatures are extremely cold.

Vehicle sound: malfunction! Pedestrians cannot hear vehicle. Please contact Service

There is a malfunction in the vehicle sound function. Drive extremely carefully, since other road users may not be able to hear your electric vehicle. Drive to an authorized Audi dealer or authorized Audi Service Facility immediately to have the malfunction corrected.

Brakes

General information

You can apply the vehicle's brakes using the brake pedal.

Operating noise

Noises may occur when braking depending on the speed, braking force, and outside conditions such as temperature and humidity.

When the vehicle is stationary, the brake system performs system tests at regular intervals. This can cause brief noise and haptic feedback effects on the brake pedal.

Braking effect

The response time from the brakes depends on the weather and environmental conditions. To ensure the optimal braking effect, the brake system is cleaned at regular intervals. This is done by applying the brake pads to the brake rotors for a short period of time when driving at high

speeds when the windshield wipers are switched on.

If the brake system becomes damp, for example after driving in heavy rain, the braking effect may be delayed. Other factors that could temporarily increase the response time of the brakes include:

- Wet conditions
- Low temperatures, ice, and snow
- Roads covered in salt
- Dirty brake pads

Corrosion

Corrosion may form on the brake rotors if there is no heavy braking, if the vehicle is not driven for long periods of time, or if the vehicle is not driven frequently or for long distances. In this case, braking heavily several times while driving at high speeds can clean the brake rotors ⇨ ⚠.

Select the “N” position when doing this, so that recuperation is not used for braking.

Brake pads

New brake pads do not achieve their full braking effect during the first 500 miles (800 km). They must be “broken in” first. However, you can compensate for the slightly reduced braking force by pressing firmly on the brake pedal. Avoid heavy braking during the break-in period.

Brake pad wear depends largely on the way the vehicle is driven and on operating conditions. Brake pad wear increases when driving frequently in the city or short distances or when using a very sporty driving style.

Automatic post-collision braking system

The automatic post-collision braking system can help to reduce the risk of sliding and of additional collisions after an accident. If the airbag control module detects a collision, the vehicle is braked by the ESC.

The vehicle does not brake automatically if one of the following occurs:

- You are pressing the accelerator pedal, or
- The braking force generated by the pressed brake pedal is greater than the braking force that would be initiated by the system

- The ESC, the brake system, or the vehicle electrical system is not functioning

WARNING

- Only apply the brakes for the purpose of cleaning the brake system when road and traffic conditions permit. You must not endanger other road users because this increases the risk of an accident.
- Due to the risk of injury, only have an authorized Audi dealer or authorized Audi Service Facility work on the brake system. Incorrect repairs could impair the function.
- Never let the vehicle roll while the drive system is switched off because this increases the risk of an accident.
- During automatic braking maneuvers, the brake pedal may move downward automatically. To reduce the risk of injury, do not place your foot under the brake pedal.

Note

- Never let the brakes “rub” by pressing the pedal lightly when braking is not actually necessary. This can cause the brakes to overheat and increases braking distance and causes wear.
- Observe the important information for driving downhill ⇒ *page 98*. This especially applies when towing a trailer.



Tips

- If you retrofit your vehicle with a front spoiler, wheel covers or similar items, make sure that the air flow to the brakes is not obstructed. Otherwise the brake system can overheat.
- Also refer to the information about brake fluid ⇒ *page 234*.

Messages

The following messages may appear depending on the vehicle equipment:

BRAKE /  **Brakes: malfunction! Safely stop vehicle**

There is a malfunction in the brake system. If **ABS** /  and  also turn on, there is a malfunction in the ABS, ESC, and braking distribution. If the brake booster is not working, you have to use much more force when braking the vehicle.

Do not continue driving. See an authorized Audi dealer or authorized Audi Service Facility for assistance. Read and follow the other safety precautions ⇒ .

BRAKE /  **Brake pads: wear limit reached. You can continue driving. Please contact Service**

The brake pads are worn. Drive to an authorized Audi dealer or authorized Audi Service Facility as soon as possible to have the malfunction corrected.

Brake booster: limited functionality. You can continue driving

The brake booster has limited availability or is not available.

- If the message appears while the vehicle is stationary with the ignition switched off, there is **no** malfunction. The brake booster will be fully functional when the ignition is switched on. Before exiting your vehicle, secure it from rolling ⇒ *page 91*.
- If the message appears while the vehicle is stationary with the ignition switched on, there is a malfunction. Secure the vehicle against rolling ⇒ *page 91*. Remove your foot from the brake pedal. Switch the ignition off and back on. If the message still appears or it appears while driving, drive immediately to an authorized Audi dealer or authorized Audi Service Facility to have the malfunction corrected. The brake booster is available, but its effectiveness is reduced. The braking performance may be different compared to the usual performance.

Brake booster: deactivated. See owner's manual

The brake booster remains active for a brief period of time after switching off the ignition. Secure the vehicle against rolling ⇒ *page 91*.

Other indicator lights

When you switch the ignition on, the **BRAKE** /  indicator light turns on briefly to check the

function. If the indicator light does not turn on, there is a system malfunction.

If **BRAKE** /  stays on, there is a malfunction in the brake system.

 – A high load was placed on the brakes from driving downhill for a long period of time. Follow the instructions in the message to utilize recuperation and to relieve the brakes.

WARNING

If a malfunction occurs in the ABS, ESC, and braking distribution, interventions that stabilize the vehicle will no longer be available. This could cause the vehicle to swerve, which increases the risk that the vehicle will slide. Do not continue driving. See an authorized Audi dealer or authorized Audi Service Facility for assistance.

Electromechanical parking brake

Operation

The  button is located in the center console above the selector lever ⇒ *page 92, fig. 79*.

Operating the parking brake

The electromechanical parking brake is used to secure the vehicle from rolling away unintentionally.

- ▶ Press the  button. The parking brake will be set. Or:
- ▶ The parking brake activates automatically when the ignition is switched off.

If **PARK** /  appears, the parking brake is holding the vehicle. You can remove your foot from the brake pedal.

If the red indicator light flashes, the braking force has not built up enough or it has decreased. When parking the vehicle, also secure it against rolling ⇒ *page 91*.

Enabling rolling ability (neutral)

In situations where the parking brake should not activate automatically, for example in a car wash, follow these steps:

Requirement: the vehicle is stationary, the ignition is on, the brake pedal is pressed, the “N” selector lever position is selected.

- ▶ Confirm the notification in the MMI. Or:
- ▶ Applies to MMI: Select on the home screen: **VEHICLE > Settings & Service > Idle > Bring to an idle**.
- ▶ If you exit the vehicle, it will still be able to roll.
- ▶ To secure the vehicle against rolling again, press the  button or switch off the drive system by pressing the **START STOP** button.
- ▶ Applies to: MMI: To turn the notification when selecting the “N” selector lever position off or on, select on the home screen: **VEHICLE > Idle > Show pop-up in the N position**.

WARNING

- To reduce the risk of an accident, always make sure the vehicle is situated safely while stationary.
- If the parking brake is set, it can release automatically when the accelerator pedal is pressed. To reduce the risk of an accident, never press the accelerator pedal without paying attention.
- If the power supply fails, you cannot set the parking brake once it is released, or release it if it is set. Secure the vehicle against rolling before exiting the vehicle ⇒ *page 91*. See an authorized Audi dealer or authorized Audi Service Facility for assistance.

Note



The parking brake must not activate automatically when in a car wash with conveyor belts. Make sure the vehicle is able to roll. To reduce the risk of damage, do not switch the ignition off.

Tips

- Noises when the parking brake is set and released are normal and are not a cause for concern.
- The parking brake goes through a self-test cycle at regular intervals when the vehicle is stopped. Any noises associated with this are normal.

Emergency braking function

Emergency braking should only be used in an emergency, if the standard brake pedal is malfunctioning or obstructed. When the emergency braking function is activated, the braking effect is similar to a heavy braking maneuver.



- ▶ Press and hold the  button while driving.
- ▶ An audio warning signal will sound and emergency braking will begin.
- ▶ If you press the  button, emergency braking will be canceled.



WARNING

Heavy braking while driving through curves or in poor road or weather conditions can cause the vehicle to slide or the rear of the vehicle to swerve, which increases the risk of an accident.

Messages

The following messages may appear depending on the vehicle equipment:

 /  Parking brake: malfunction! Safely stop vehicle. See owner's manual

 /  Parking brake: malfunction! Please release parking brake

If one of the two messages appears, there is a malfunction in the parking brake. If the message appears while stationary, check if the parking brake is released and can be reset. If this is the case, switch the ignition off and back on.

If the message stays on, if the parking brake cannot be released, or if the message appears while driving, do not continue driving. Secure the vehi-

cle against rolling before exiting the vehicle ⇒ *page 91*. See an authorized Audi dealer or authorized Audi Service Facility for assistance.

Parking brake: malfunction! Please contact Service

There is a malfunction in the parking brake. Drive to an authorized Audi dealer or authorized Audi Service Facility immediately to have the malfunction corrected. Do not park the vehicle on inclines and secure it against rolling before exiting the vehicle ⇒ *page 91*.

/ Parking brake: warning! Vehicle position too steep

The braking force may not be enough to secure the vehicle from rolling away. Park the vehicle in a place with less of an incline.

/ Parking brake: applied

The parking brake is set. Keep the brake pedal pressed down and select a selector lever position to deactivate the parking brake.

Take over!

The vehicle cannot be held in place automatically. Press the brake pedal to secure the vehicle from rolling away unintentionally.

Special driving situations

Driving uphill and downhill

When driving uphill, downhill, or at high altitudes, note the following information:

- Drive slowly and carefully.
- Do not try to turn around if you cannot safely drive on an incline or hill. Instead, drive in reverse.
- Utilize the recuperation braking effect when driving downhill by selecting the “B” driving program ⇒ *page 92*. This reduces the load on the brakes.
- Apply the brakes in intervals and do not press the brake pedal continuously. ▶

 **WARNING**

- Only drive on inclines that your vehicle is designed to handle. Do not exceed the hill climbing ability of your vehicle. Your vehicle could tip or slide.
- Do not drive at an angle on steep inclines and hills. If your vehicle is about to tip, you must immediately start steering in the direction of the downward slope to reduce the risk of an accident.

Driving through water

If you must drive through water, follow these instructions:

- Check the stability of the ground, the current, and the water depth. If the ground is unstable, there is a strong current, or there are waves, the water must only reach **up to the lower edge of the body at the most**.
- Drive carefully and no faster than at walking speeds to prevent the front of the vehicle from creating waves, because they could splash above the lower edge of the body. Oncoming vehicles could also create waves.
- Do not stop the vehicle while in the water.
- Do not drive in reverse.
- Do not switch off the drive system.

 **WARNING**

After driving through water, press the brake pedal carefully to dry the brakes so that the full braking effect will be restored.

 **Note**

Vehicle components such as the motor, drive system, suspension, or electrical system can be severely damaged by driving through water.

 **Tips**

If possible, avoid driving through salt water because it increases the risk of corrosion. Use fresh water to clean any vehicle components that come into contact with salt water.

Driving dynamic

Audi drive select

Introduction

Applies to: vehicles with Audi drive select

Drive select makes it possible to experience different types of vehicle characteristics in one vehicle. With different driving modes, the driver can change the setting, for example from sporty to comfortable. This allows you to adjust the settings to your personal preferences. This makes it possible to combine settings such as a sporty drivetrain setting with comfortable steering.

Selecting an Audi drive select mode

Applies to: vehicles with Audi drive select

The drive select button is located above the selector lever in the center console.

- ▶ Press the drive select button repeatedly until the desired mode appears in the instrument cluster or center display. Or:
- ▶ Applies to MMI: Select on the home screen: **VEHICLE > Audi drive select**.

You can change the driving mode when the vehicle is stationary or while driving. If traffic permits, briefly remove your foot from the accelerator pedal after changing modes so that the mode you have selected will be activated for the drive system.

The following modes may be available depending on the equipment:

efficiency – The vehicle switches to a fuel-efficient vehicle setup and supports an economic driving style. The maximum speed is reduced.

comfort – Provides a comfort-oriented vehicle setup and is suited for long drives on highways.

auto – Provides an overall comfortable yet dynamic driving feel.

dynamic – Provides a sporty driving feel and is suited to a sporty driving style.

Individual – Provides the option for personalized vehicle settings. Press  to configure the mode
⇒ page 100, Individual settings.

Tips

- When the ignition is being switched on, individual systems, such as the drive system, will be reset to a balanced setting. Select the current mode again to attain its full configuration.
- Audi recommends the **auto** mode for everyday driving.

Individual settings

Applies to: vehicles with Audi drive select

The equipment in your vehicle will determine which settings you can adjust.

Drive

The drive system will react to accelerator pedal movement more quickly or in a more balanced manner.

Steering

The power steering will adapt. Light steering is suitable for long trips on highways or smooth driving around curves, for example.

Suspension

The suspension adjusts to be tighter or more comfort-oriented when it comes to compensating for uneven spots on the road.

Suspension

Adaptive dampers

Applies to: vehicles with suspension control

The adaptive dampers are an electronically-controlled damping system. The firmness of the suspension will adapt to the driving conditions and the driving situation. The settings depend on the selected Audi drive select* mode.

Ground clearance

The vehicle height and clearance can be influenced by the following factors:

- Change in temperature
- Change in load

! WARNING

To reduce the risk of injury, make sure no one gets pinched when the vehicle level is changing, for example when cleaning the underbody or the wheel housings.

! Note

Always make sure there is enough clearance above and below the vehicle. This is especially important for entrances with height restrictions, for example, before driving into underground garages. You could also scrape the ground when driving over the edges of curbs or on steep ramps, which could damage your vehicle.

Messages

The following messages may appear depending on the vehicle equipment:

! Suspension: malfunction! You can continue driving

There is a malfunction. See an authorized Audi dealer or authorized Audi Service Facility for assistance.

Steering**Description**

Electromechanical steering supports steering movements by electronically adapting the power steering depending on the vehicle speed. The settings depend on the selected Audi drive select* mode.

Progressive steering

Applies to: vehicles with progressive steering

The driving dynamic and driving stability are increased by the steering ratio based on the steering wheel angle. The steering is very direct when the steering wheel angle is sharp, and indirect when the angle is low. This enables comfortable maneuvering and a precise steering response at higher driving speeds.

Messages

The following messages may appear depending on the vehicle equipment:

! Steering: malfunction! Please stop vehicle

The power steering may have failed. Adapt your driving style immediately to compensate for the fact that it may be more difficult to turn the steering wheel, and stop your vehicle in a safe location as soon as possible. Secure the vehicle against rolling before exiting the vehicle ⇒ *page 91*. Do not continue driving. See an authorized Audi dealer or authorized Audi Service Facility for assistance.

! Steering: malfunction! Please stop vehicle

There is a malfunction in the electronic steering lock. You cannot turn the ignition on. Secure the vehicle against rolling before exiting the vehicle ⇒ *page 91*. Do not tow your vehicle because it cannot be steered. See an authorized Audi dealer or authorized Audi Service Facility for assistance.

! Steering: malfunction! You can continue driving

There is a malfunction in the steering system. Steering may be more difficult or more sensitive. Adapt your driving style. Have the steering system checked immediately by an authorized Audi dealer or authorized Audi Service Facility. Please note that the red indicator light may turn on after restarting the drive system. Do not continue driving if it does.



! Steering lock: malfunction! Please contact Service

There is a malfunction in the electronic steering lock. Drive immediately to an authorized Audi dealer or authorized Audi Service Facility to have the malfunction repaired.

! WARNING

Do not tow your vehicle if there is a malfunction in the electronic steering lock because this increases the risk of an accident.

i Tips

If the  or  indicator light only stays on for a short time, you may continue driving.

All wheel drive (quattro)

Description

Applies to: vehicles with all wheel drive

The all-wheel drive system distributes the driving power variably to the front and rear axle to improve the driving characteristics. It works together with selective wheel torque control, which can activate when driving through curves
⇒ *page 102.*

The all-wheel drive system is designed for high motor power. Your vehicle is exceptionally powerful and has excellent driving characteristics both under normal driving conditions and on snow and ice. Always read and follow safety precautions
⇒ .

WARNING

- Even in vehicles with all wheel drive, you should adapt your driving style to the current road and traffic conditions to reduce the risk of an accident.
- The braking ability of your vehicle is limited to the traction of the wheels. In this way, it is not different from a two wheel drive vehicle. Do not drive too fast because this increases the risk of an accident.
- Note that on wet streets, the front wheels can “hydroplane” if driving at speeds that are too high. Unlike front wheel drive vehicles, the motor RPM does not increase suddenly when the vehicle begins hydroplaning. Adapt your speed to the road conditions to reduce the risk of an accident.

Messages

The following messages may appear depending on the vehicle equipment:

 **All-wheel drive: malfunction! Limited stability. Please contact Service**

Driving stability is reduced. Continue driving with caution. Drive to an authorized Audi dealer or authorized Audi Service Facility immediately.

Electronic Stabilization Control

Description

Electronic Stabilization Control (ESC) supports driver safety. It reduces the risk of slipping and improves driving stability. ESC detects critical situations, such as oversteering and understeering of the vehicle, the drive wheels spinning, or the risk of the vehicle tipping.

The brakes are applied or the motor torque is reduced in order to stabilize the vehicle.

The following stabilization functions are integrated into the ESC, among others:

Anti-Lock Braking System (ABS)

ABS prevents the wheels from locking when braking. The vehicle can still be steered even during hard braking. Apply steady pressure to the brake pedal. Do not pump the pedal.

Noises will indicate when the system is working.

Anti-Slip Regulation (ASR)

ASR reduces drive power when the wheels begin spinning and adapts the power to the road conditions. This will increase the driving stability.

Electronic Differential Lock (EDL)

The EDL applies the brakes to wheels that are slipping and transfers the drive power to the other wheels. This function is not available at higher speeds.

In extreme cases, EDL automatically switches off to keep the brake on the braked wheel from overheating. The vehicle is still functioning correctly. EDL will switch on again automatically when conditions have returned to normal.

Selective wheel torque control

Selective wheel torque control is used when driving on curves. Braking is targeted toward the 

wheels on the inside of the curve as needed. This allows more precise driving in curves.

WARNING

- The ESC and its integrated systems cannot overcome the limits imposed by natural physical laws. This is especially important on slippery or wet roads. If the systems begin acting to stabilize your vehicle, you should immediately alter your speed to match the road and traffic conditions. Do not let the increased safety provided tempt you into taking risks. This could increase your risk of a collision.
- Please note the risk of a collision increases when driving fast, especially through curves and on slippery or wet roads, and when driving too close to objects ahead. There is still a risk of accidents because the ESC and its integrated systems cannot always prevent collisions.
- Accelerate carefully when driving on smooth, slippery surfaces such as ice and snow. The drive wheels can spin even when these control systems are installed and this can affect driving stability and increase the risk of a collision.
- As the vehicle load increases, especially the roof load, the vehicle's center of gravity also increases along with the risk of the vehicle tipping. To reduce the risk of an accident, always adapt your driving style to the current conditions and avoid sudden driving maneuvers.

Tips



The ABS and ASR only function correctly when all four wheels have a similar wear condition. Different tire sizes can lead to a reduction in motor power.

Operation

The  button is located above the selector lever in the center console. The ESC is automatically switched on when the ignition is switched on.

Limiting ESC



In some situations, it may make sense to limit the stabilizing function of the ESC so that the wheels can spin, for example to rock a vehicle to free it when it is stuck or to drive with snow chains. The ESC can also be limited to provide more sporty driving characteristics with fewer stabilizing corrective actions.

- To limit the ESC, press the  button briefly. The  indicator light will turn on.
- To completely reactivate the ESC stabilization function, press the button again. The indicator light turns off.

Switching off ESC

Applies to: vehicles with ESC OFF mode

For a more active control of the vehicle where the stabilizing functions of the ESC cannot intervene, the ESC can be switched off.

- To switch off the ESC, press and hold the  button for more than three seconds. The  and **ESC OFF** indicator lights turn on.
- To completely reactivate the ESC stabilization function, press the button again. The indicator lights turn off.

WARNING

- When the ESC is switched off or limited, there will be no vehicle stabilization or it will be limited. The driving wheels could spin and the vehicle could swerve, especially on slick or slippery road surfaces. When there is a heavy vehicle load and sudden driving maneuvers, it may not be possible to prevent the vehicle from tipping under certain circumstances, which increases the risk of an accident.
- Because of the increased risk of an accident, only drive with the ESC switched off or limited when it is necessary. Reactivate the ESC as soon as possible.



Tips

- If the ESC is limited, switched off, or malfunctioning, systems with an automatic braking intervention function may not be fully available.

- If malfunctions occur in other systems or certain driver assist systems are active, the ESC must be switched on by the system. The ESC may switch on automatically and cannot be operated with the button.

Messages

The following messages may appear depending on the vehicle equipment:

 **ABS** /  **Stabilization control (ESC/ABS): malfunction! See owner's manual**

There is a malfunction in the ABS or EDL. This also causes the ESC to malfunction. The brakes still function with their normal power, but ABS is not active.

Drive to an authorized Audi dealer or authorized Audi Service Facility immediately to have the malfunction corrected.

Other indicator lights

If  blinks while driving, the ESC is actively regulating. Operating noises may occur. If the indicator light stays on, the ESC has been switched off due to system needs. The indicator light turns off when the system is fully functional.

High-voltage system

General information

Introduction

All work done on the high-voltage system must only be performed by certified high-voltage technicians at authorized Audi dealers or authorized Audi Service Facilities in accordance with Audi guidelines.

The high-voltage system is composed of the following high-voltage components, among other things: the high-voltage battery, the power electronics, the electric motor, the high-voltage A/C compressor, the high-voltage heater, the charging system and charging port, and the orange high-voltage wiring.

The high-voltage battery is located in the underbody of the vehicle. You must not service the high-voltage battery yourself.

WARNING

The voltage in the high-voltage system is high enough to cause fatal injuries. Touching a damaged high-voltage component can result in a fatal electric shock. The components in the high-voltage system are marked with a warning label which warns against the high-voltage.

- The voltage level in the high-voltage system is still dangerous and potentially life-threatening when the ignition is switched off.
- Do not touch any of the contacts in the charging port, for example when cleaning the charging unit. If you would like to clean the charging unit, use only a dry cloth and no other tools, such a screwdriver or a brush.
- Never perform work on the orange high-voltage cables or on other high-voltage components. Only authorized repair facilities that are certified may perform work on the high-voltage system.
- Never damage, alter or remove the orange high-voltage cable or disconnect it from the high-voltage system.

- Never perform any work using cutting, shaping or sharp-edged tools or heat sources near the high-voltage system and high-voltage cables.
- Gases that escape from the high-voltage battery can be poisonous or flammable.
- Damage to the high-voltage battery can cause poisonous gases to escape, either immediately or at a later time. The escaping gases can also cause a fire. If you notice the smell of fire or gases, follow these steps:
 - Do not inhale the gases.
 - Park the vehicle in a safe place outdoors that is not near buildings or vehicles, roof overhangs, carports, or similar structures.
 - Switch the ignition off and evacuate the vehicle.
 - Leave the danger area.
 - Contact emergency services.
- Do not expose yourself to any leaking fluids and do not come into contact with them.
- The high-voltage battery electrolyte fluid is caustic. If electrolyte fluid comes into contact with the skin, flush the affected area for at least 15 minutes with clean water. Then wash the affected area with soap. Have the affected area examined by a medical professional.
- In the event of a technical emergency, inform the responders that the vehicle is equipped with a high-voltage battery.

Note

The high-voltage system can be damaged if the vehicle underbody comes into contact with the ground. Immediately drive your vehicle to an authorized repair facility and have it inspected.

Tips

The power output may be limited when the high-voltage battery is cold. This will decrease the remaining range and the performance output can be severely limited only a short time after starting to drive.

- To prevent this, make sure that the high-voltage battery is sufficiently charged

before parking the vehicle when the outside temperatures are low. Charge the high-voltage battery if necessary.

- Additionally, Audi recommends setting a departure time in the myAudi app. This will

heat up the high-voltage battery before starting to drive.

Charging the high-voltage battery

Introduction

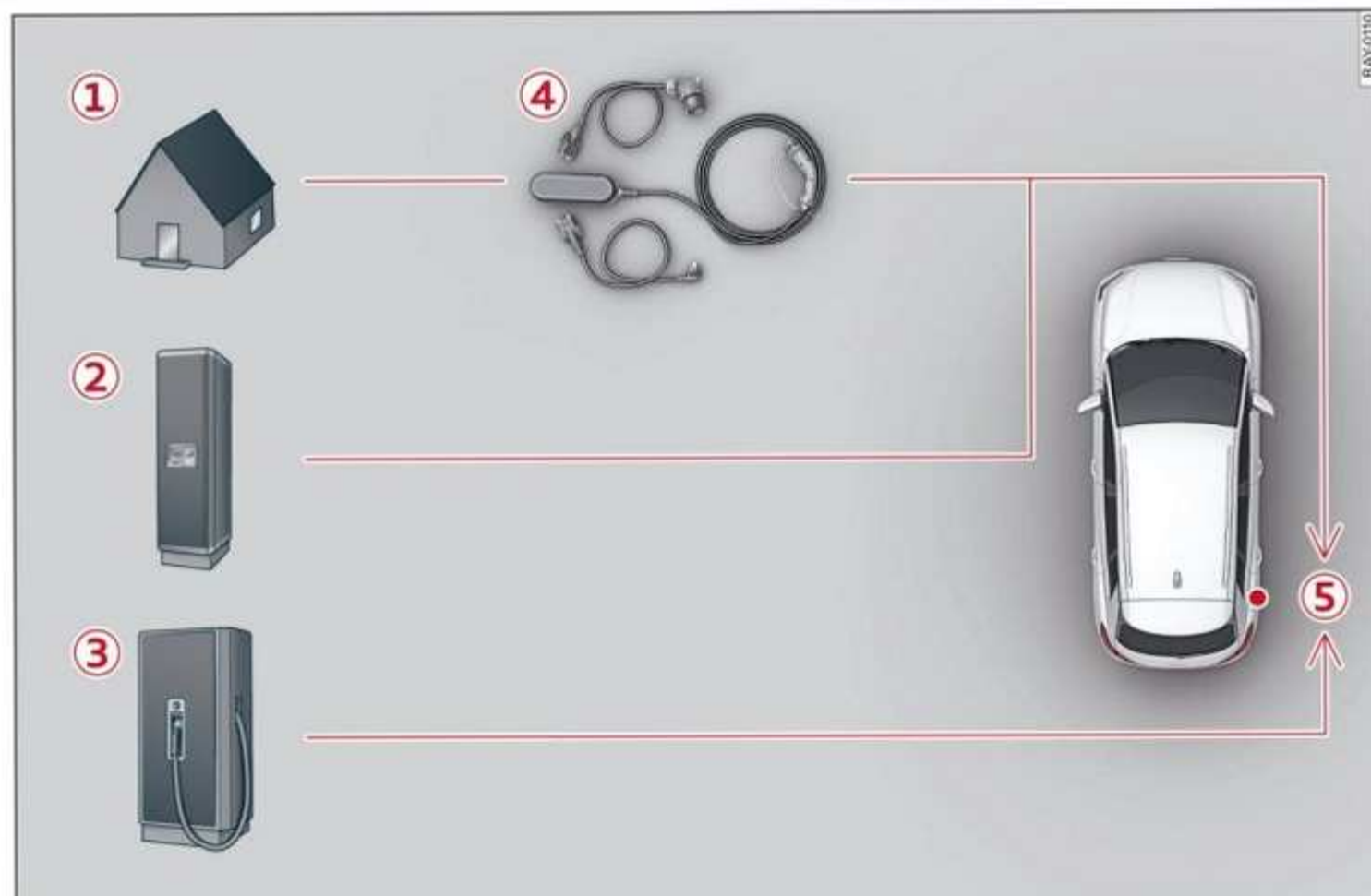

Fig. 80 Charging options overview

The following options are available to charge the high-voltage battery:

Charging method	Charging cable	Charging port on the vehicle
① Charge with household and industrial alternating current (AC) sockets	④ Audi e-tron Charging System Compact ⇒ page 118	⑤
② Charge at public alternating current (AC) charging stations	Charging station cable	⑤
③ Quick charge at public direct current (DC) charging stations	Charging station cable	⑤

Audi recommends using alternating current (AC) to charge the high-voltage battery at industrial sockets, charging stations, or a wallbox. This will allow you to achieve higher efficiency and a con-

siderably shorter charging time when compared to charging with a household socket. ▶

Only use household sockets to charge with the Audi e-tron charging system in special circumstances, when it is not possible to charge with an industrial alternating current (AC) socket or with a public alternating current (AC) or direct current (DC) charging station.

High-voltage batteries age over time, which reduces the available range. High-voltage batteries can also age based on how they are used: frequently charging the high-voltage battery completely can accelerate the aging of the battery and reduce the available range.

Charging at household and industrial sockets or at public charging stations with alternating current (AC)

The vehicle's high-voltage battery can be charged with alternating current (AC) via the charging port .

Quick charging at public direct current (DC) charging stations

The vehicle's high-voltage battery can be charged at a direct current (DC) charging station using the charging port . The charging time shortens significantly compared to charging with alternating current (AC). The charging cable used may be a maximum of 98 feet (30 m).

Charging time

The duration of the charging process may vary based on the following factors:

- Sockets being used (household or industrial sockets)
- Country-specific system voltage, current strength and number of available phases
- Household connection
- The value set for the charging power level on the Audi charging system control unit
- Fluctuations in the system voltage
- The temperature outside the vehicle
- The temperature of the high-voltage battery and the Audi charging system control unit.
- Settings for the climate control inside the vehicle
- Current capacity of the charging connector
- Whether the ignition is on or off

Important safety precautions

WARNING

Short circuiting, electric shock, explosions, fire, and severe burns can result from charging the battery incorrectly (for example by disregarding general safety precautions, using unsuitable or damaged sockets and charging cables, or charging with unsuitable electrical equipment) and can lead to serious and fatal injuries.

- Do not charge using sockets/electrical equipment that is clearly damaged or installed incorrectly.
- Never use charging equipment that is clearly damaged and/or dirty. Check the charging equipment for damage before every use.
- Never modify or repair any electrical components, especially the high-voltage system.
- Never charge in areas at risk for explosions. The components in the charging equipment can trigger sparks, which can cause flammable or explosive fumes to ignite. To reduce the risk of explosions, especially in garages, make sure the Audi e-tron charging system control unit is at least 19 inches (50 cm) above the floor when charging.
- Never use the charging equipment with an extension cord, a cable reel, a power strip, or an adapter, for example, a travel adapter or timer.
- Do not touch the contacts on the vehicle charging port or charging equipment.
- Do not insert any objects in the vehicle charging port or in the charging equipment.
- Always protect the sockets and connections from water, moisture and other fluids.
- Only use the charging equipment provided by the factory or the charging station cable.

WARNING

Applies to: Audi charging systems

Sockets that are installed incorrectly can cause electric shock or fire when charging the high-voltage battery using the vehicle charging connection.

- Read all information and safety precautions for Audi charging systems before using them.
- Monitor the Audi charging system if it is being used near children.
- Installation and setup of the household connection for Audi charging systems may only be performed by a qualified electrician. The qualified electrician is thereby responsible for adhering to applicable standards and regulations.
- Make sure that the household socket is grounded and shielded from water.
- If Audi charging systems do not function according to the specifications in the operating manual, they must not be used. Contact an authorized Audi dealer or authorized Audi Service Facility.
- Audi charging systems are intended for use in private and semi-private areas (for example, private property and company parking lots). Depending on the country where the vehicle is operated, charging with a mode 2 charging cable (meaning charging with the Audi charging system) may be prohibited in public areas. Contact an authorized Audi dealer or authorized Audi Service Facility for more information.
- Operate the Audi charging systems in power networks that are properly grounded. It cannot be used with non-grounded power networks (such as IT networks).
- When charging the high-voltage battery using household/industrial sockets, the electrical installation can be used at full capacity. Audi recommends having a qualified electrician regularly inspect the electrical installations that are used for charging.
- If possible, disconnect Audi charging systems from the power network during a thunderstorm.
- Never submerge the Audi charging systems or the connectors in water.
- Audi charging systems must only be cleaned when the control unit is completely disconnected from the power supply and from the vehicle. Use a dry towel to clean.

- Audi charging systems are only intended for use with Audi vehicles. Using the devices on vehicles made by another manufacturer is not authorized.

Note

- If the vehicle is not being used for long periods of time, the high-voltage battery must be charged after four months at the latest or the vehicle must be continuously connected to a power source (for 50% charging target ⇒ *page 113*). Otherwise, the high-voltage battery could become damaged.
- Make sure that you always use the correct charging equipment for the country in which it is being used. Contact an authorized Audi dealer or authorized Audi Service Facility for more information.

Tips

- Your vehicle can only be charged at charging stations that meet the requirements in the respective country and meet the following standards, at a minimum:
 - GB/T 18487.1 and GB/T 20234 (China)
 - IEC 61851 and IEC 62196 (Europe)
 - SAE J1772 (North America, Japan)
- You can use your Audi charging system if there is a household or industrial connection available at the charging station.

Tips

Applies to: Audi charging systems

- For an uninterrupted charging process, Audi recommends only charging using sockets that are connected to a separately protected circuit.
- Audi recommends using Audi charging systems in the wall mount clip* during operation. If this is not possible, always position Audi charging systems on a secure surface during the charging process ⇒ .
- To reduce the risk of overheating during operation, do not place Audi charging systems in direct sunlight for long periods of time. If the control unit is overheated, the charging process is automatically paused until the

temperature has lowered back within the normal range.

Charging

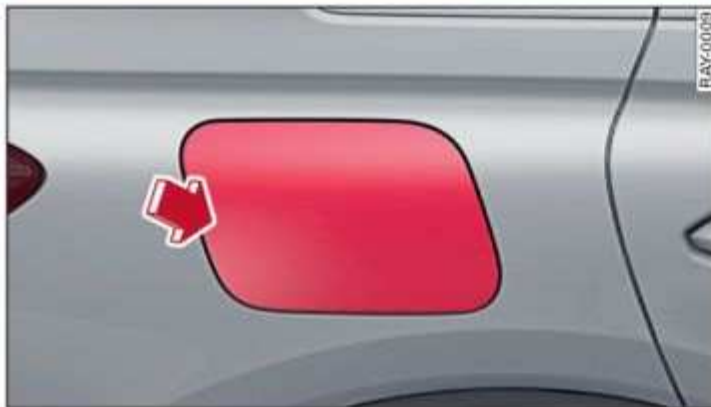

Fig. 81 Right rear side of the vehicle: opening the high-voltage charging port door



Fig. 82 Charging unit: charging port and charging display

Connecting the charging cable

If you charge your vehicle at a charging station, the following sequence of steps may vary. Follow the manufacturer guidelines and operating instructions for the charging station.

Requirement: drive ready mode has ended and the parking brake must be set.

- Select the preferred charging mode so that the vehicle either starts charging immediately, or starts charging at a later time ⇒ *page 112*.
- Select your preferred setting for automatic unlocking of the charging connector (determines if the charging connector can be unplugged when the vehicle is locked, or if it must be unlocked) ⇒ *page 114*.
- If necessary, remove the charging cable from the vehicle ⇒ *page 117, Transporting*.
- Remove the cap from the charging cable if necessary.







- First connect the charging cable to the power supply, or remove it from the charging station.
- Unwind the charging cable completely.
- Unlock the vehicle.
- To open the charging port door, press on the left side of the door ⇒ *fig. 81*.
- If you would like to use quick charging at public direct current (DC) charging stations, remove the charging port cover ②.
- Insert the charging connector into the charging port, and press upward on it lightly for approximately 5 seconds.
- Check if the charging mode shown ① is the one you would like to use for the charging process ⇒ *page 110*.

While charging

The charging display on the charging unit ① will pulse green while charging. It will pulse  in the instrument cluster. A label on the charging unit ③ informs you about the various displays ⇒ *page 110*.

The charging connector is locked while charging and cannot be removed.

Depending on the selected view ⇒ *page 14*, the following information about the charging process is displayed in the instrument cluster:

- : range
- : remaining charging time until the charging process is complete
- : current battery charge level
- : date and time of when the charging process was completed
- : charging speed (additional range per hour)
- : charging power (depends on the selected power source)

To access the charging process information at a later time, select in the instrument cluster: Vehicle functions tab >  button > **Charging**.

Ending the charging process

You can interrupt or end the charging process at any time:

Applies to: DC-charging process

- Once the selected charging target is reached, the charging process will stop automatically ▶

and the charging connector will unlock and remain unlocked.

- To stop the charging process while it is active, follow the applicable instructions at the charging station, or
- Applies to: MMI: Select on the home screen: **VEHICLE > Charging > S**. The colored bar in the **S** button will turn off.
- Disconnect the charging connector and close the charging port door.

Applies to: AC-charging process

- Unlock the vehicle.
- Remove the charging connector. If the charging connector is not removed within 30 seconds, it will automatically lock again and the charging process may resume.
- Close the charging port door.
- Disconnect the charging cable from the power supply if necessary or return it securely to the charging station.
- Install the protective caps on the charging cable again.
- If you are transporting the charging cable in the vehicle, store it securely ⇒ *page 117*.

If the charging connector cannot be removed, you must unlock it manually ⇒ *page 111*.

If you cannot disconnect the charging connector from the charging station, authenticate yourself again at the charging station and then try again to disconnect the charging connector. If you still cannot disconnect the charging connector from the charging station, contact the charging station operator.

WARNING

- Do not disconnect the charging cable from the socket or the vehicle charging port while the vehicle is charging. End the charging process before removing the charging cable from the socket in order to reduce the risk of damaging the connector contacts from sparks.
- If the charging unit is damaged, do not charge using the charging port to reduce the risk of injury.
- If the charging unit is damaged or the charging port door cannot close or is missing, drive immediately to an authorized Audi dealer or authorized Audi Service Facility and have the malfunction corrected to reduce the risk of injury.



Note

If you drive with the charging unit open, both the charging port door and the electronics installed behind it could be damaged. Check each time after charging if the port door is locked before you start driving the vehicle.

Tips

- If the parking brake is set, it could create noises when the charging connector is connected.
- Remove ice and snow in the charging unit using a hand brush and solvent-free deicing spray.
- The vehicle reception systems, such as radio reception, may be limited during charging.

Charging display

The charging display is an LED light on the charging unit  ⇒ *page 109, fig. 82* that indicates the charging status. A label on the charging unit 

⇒ *page 109, fig. 82* informs you about the various displays. The following table explains the displays.

LED on the charging unit		Meaning
Off		Vehicle charging system is in sleep mode.
		Charging process is interrupted.
White	Pulsating/flashing	Connection between the power source and the vehicle is being established.

LED on the charging unit		Meaning
Green	Pulsating	The high-voltage battery is charging.
	Pulsating and flashing red	Emergency charging active. The high-voltage battery is being charged with reduced charging power. The charging connector may have been unable to lock correctly or the communication with the charging equipment may be interrupted.
	Flashing	A timer is active, but charging has not started yet.
	Illuminated	High-voltage battery charging process is completed.
Red	Illuminated	The charging connector may not be able to lock correctly in the vehicle charging port. Check if the charging connector is inserted correctly. Disconnect the charging connector, reconnect it to the charging socket, and press it upward lightly for five seconds, or use a different charging station. If the LED stays turned on, there is a malfunction either in the vehicle charging system or at the power source. See an authorized Audi dealer or authorized Audi Service Facility for assistance if necessary.
		The outside temperature is too low or too high.

Tips

The charging display modes can also be shown in the instrument cluster display .

Manual release

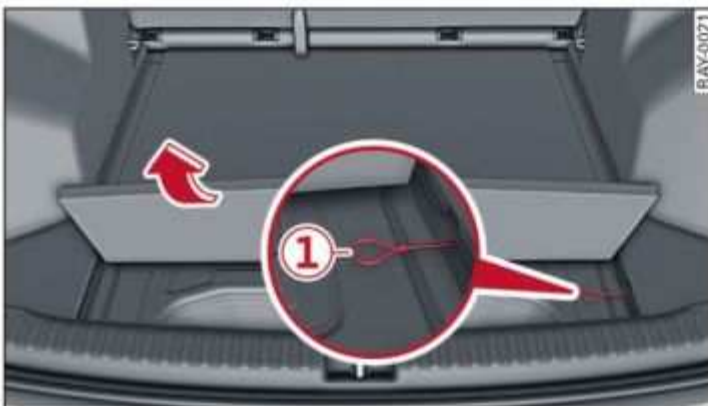

Fig. 83 Right side of the luggage compartment: charging connector manual emergency release

Manually releasing the charging port door

- ▶ See an authorized Audi dealer or authorized Audi Service Facility if you cannot open the charging port door.
- ▶ Afterward, drive to an authorized Audi dealer or authorized Audi Service Facility to have the malfunction repaired.



Manually releasing the charging connector

If you are not able to pull the charging connector out of the vehicle charging port, there may be a

malfunction. You must use the manual release to release the vehicle charging connector.

In some cases, an electric emergency release of the charging connector is sufficient.

Requirement: the parking brake is set and the vehicle is unlocked.

- ▶ End the charging process ⇒ *page 109, Ending the charging process.*
- ▶ To trigger the electric emergency release, unlock the vehicle three times in a short period of time using the vehicle key and then immediately try to disconnect the charging connector. If the charging connector remains locked, then you will need to emergency release the charging connector manually.
- ▶ Open the luggage compartment lid.
- ▶ Lift the cargo floor cover up and carefully pull on the yellow loop  ⇒ .
- ▶ Remove the charging connector.
- ▶ Insert the cargo floor cover again and close the luggage compartment lid.
- ▶ Drive to an authorized Audi dealer or authorized Audi Service Facility immediately to have the malfunction corrected.



If the charging connector still cannot be removed after using the manual release, there is still a malfunction. The charging connector could also be frozen in place if the temperatures are below ▶

freezing. See an authorized Audi dealer or authorized Audi Service Facility for assistance in all cases.

Note

Only pull on the loop until you feel resistance. You will not hear it release. If you continue to pull, you could damage the manual release mechanism.

Messages

If the  or  indicator light turns on, then the range is low or very low. Charge the high-voltage battery.

 **Charging system: malfunction! Only AC charging is possible. Please contact Service**

 **Charging system: malfunction! Only DC charging is possible. Please contact Service**

This message appears if there is a malfunction in the charging system. See an authorized Audi dealer or authorized Audi Service Facility for assistance.

 **Charging system: malfunction! AC charging is limited. Please contact Service**

If this message appears, the vehicle is charging in emergency charging mode with reduced charging power. See an authorized Audi dealer or authorized Audi Service Facility for assistance after the charging process.

Charging system: malfunction! Error in the charging infrastructure.

This message appears, for example, if the time limit to start the charging process has been exceeded or the charging station or charging system is not compatible. Remove the charging connector and plug it into the charging port again, and then authenticate yourself at the charging station. If the message still appears, then change the charging station or use your Audi charging system.

Charging system: malfunction! Charging canceled. See owner's manual

This message appears if there is a malfunction of the vehicle charging infrastructure or the charging station during the charging process and the battery was not charged all the way, for example due to high temperatures at the charging port. Use a different charging station. If this message still appears, drive to an authorized Audi dealer or authorized Audi Service Facility.

Connector lock: malfunction! See owner's manual

This message appears if the charging connector could not be locked correctly in the charging port. Disconnect the charging connector, insert it in the charging port again, and press upward on it lightly for approximately five seconds. You can also use another charging station if available. If the message appears after a successful charging process, then the charging connector must be emergency released ⇒ *page 111*. If the message still appears even after corrective measures are taken, see an authorized Audi dealer or authorized Audi Service Facility for assistance.

Charging settings

Charging menu



Fig. 84 Center display: charging settings

Depending on the vehicle equipment, you may be able to adjust individual charging settings.

– Applies to: MMI: Select on the home screen:

VEHICLE > Charging.

– You may need to scroll to the display ⇒ *fig. 84*.

- ① Display of the current charging target or battery charge level
- ② Setting a charging target
- ③ Open additional settings
- ④ Switch timer charging mode on or off
- ⑤ Stopping the page from loading

Charging mode

When **immediate charging mode** is selected, the charging process will start immediately after the charging connector has been plugged in and the charging station has been activated, if required. When **timer charging mode** is selected, the charging process will either start later based on the timer that has already been set and activated ⇒ *page 114*, or it will start at a preferred charging time ⇒ *page 116*.

- To switch on timer charging mode, press the button . A colored bar will turn on in the button.

Charging target

Introduction

The charging target indicates the predetermined maximum charge level to which the high-voltage battery will charge. The charging target can be set manually or automatically via the battery protection function.

Audi recommends adjusting the charging target based on the usage pattern. For daily usage, Audi recommends setting the charging target at 80%. This can help to ensure the optimal the service life of the high-voltage battery. For long trips, Audi recommends setting the charging target to 100% to achieve the highest possible range. When the high-voltage battery has been charged to 100%, begin driving as soon as possible. You have the option to use the timer charging mode.

Activating the battery protection function

The battery protection function can prevent unwanted battery charge levels above 80% by automatically setting the charging target to 80%.

- ▶ To activate the battery protection function, select on the home screen: **Vehicle > Charging >  > Battery protection function.**

Applies to: immediate charging mode: If the battery protection function is active and you manually set a charging target below 80%, then the set charging target will be stored for the long term. If the battery protection function is active and you manually set a charging target above 80%,

then the set charging target will be used only once. After charging successfully, the charging target set by the battery protection function will be activated again. The battery protection function will remain active at an address for which you defined advanced charging settings ⇒ *page 116, Advanced charging settings.*

Applies to: timer charging mode: If you are charging in timer charging mode, then the battery protection function will not be used.

Setting a charging target manually

The charging target can be set when the battery protection function is active or inactive. If the battery protection function is active, a manually set charging target above 80% will only be used once for the next charging process. If the battery protection function is inactive, then the set charging target will be used for every charging process.

- ▶ Applies to: MMI: Select on the home screen: **VEHICLE > Charging.**
- ▶ When the timer is displayed, swipe your finger on the display toward the right.
- ▶ Press on the right section of the battery charge level display.
- ▶ Set the desired charging target.

If the battery protection function is inactive, the manually set charging target will be stored and used at all locations where you have not defined specific charging settings. When setting the charging target, if the vehicle is located at an address for which you have already defined advanced charging settings, then the charging target will be changed to match the advanced charging settings ⇒ *page 116, Advanced charging settings.*

Tips

If you set the charging target lower than the current battery charge level while charging, then the charging process will be canceled. If you set the charging target above the current battery charge level again, then the charging process will resume. This does not apply if you are charging at a charging station, where you have authenticated yourself manually. If

this is the case, authenticate yourself again at the charging station.

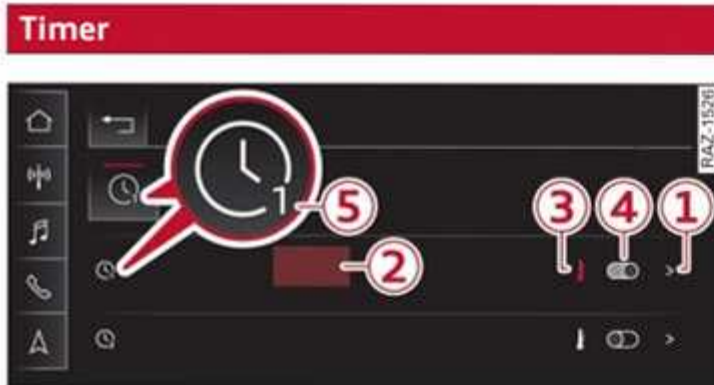

Fig. 85 Center display: timer

Possible settings

By setting a timer, you specify the latest time at which your vehicle should reach the desired charging target. When the timer is activated, it will be run regularly at the set time.

You can adjust the following settings when using a timer:

- ▶ Charging target (battery charge level at departure time, also see ⇒ page 113).
- ▶ Air conditioning for departure time

Configuring and activating the timer

- ▶ Applies to: MMI: Select on the home screen: **VEHICLE > Charging**.
- ▶ You may need to scroll to the timer display ⇒ fig. 85.
- ▶ To configure a timer, select > in the line for the desired timer ①.
- ▶ Select one or more scheduled days of the week on which the timer should be activated, and then press **Next**.
- ▶ Set the desired departure time and select **OK**.
- ▶ To also activate the climate control, press ⏴ ③. If a timer is set, then the climate control will be activated even if no charging connector is connected. If the vehicle will not be used for a long period of time, Audi recommends deactivating active timers to prevent the battery from discharging.
- ▶ To turn on a timer, press ⏵ ④.
- ▶ To use an active timer for the next charging process, select timer charging mode ⌚

⇒ page 112. A colored bar in the button will light up when timer charging mode is active.

You can turn on multiple timers at the same time. The timer that is currently active will be indicated with a number ⑤.

If the departure time set for the timer ② is too soon, the desired charging target may not be reached.

i Tips

- The following applies if automatic unlocking of the charging connector is activated: if the vehicle is not currently charging, then the charging connector is unlocked and can be disconnected, for example when waiting for a timer or a charging time frame.
- It is not possible to charge using the timer at some charging stations.

Automatic unlocking of the charging connector

Applies to: vehicles with automatic charging connector unlocking

You can set if the charging connector should automatically unlock when the charging process has ended. This will allow you or others to disconnect the charging connector even when the vehicle is locked. This function is helpful to prevent charging stations from being blocked for long periods of time, or to allow the charging connector to be disconnected without a vehicle key in private locations.

For DC charging, automatic unlocking of the charging connector is enabled permanently.

For AC charging, automatic unlocking of the charging connector is enabled at the factory and can be changed.

- ▶ Applies to: MMI: To activate or deactivate automatic unlocking for AC charging, select on the home screen: **VEHICLE > Charging > ⚙ > AC connector: unlock after charging has ended**.
- ▶ Before charging, always check if the selected settings are suitable for the current charging session.

Note

The function should only be activated if the charging cable is part of the charging station. If you use your own charging cable, there is no anti-theft protection and your charging cable could be stolen.

Plug & Charge¹⁾

Applies to: vehicles with Plug & charge

With Plug & charge, the contract information for your vehicle charging plan will be stored in the vehicle. This will allow your vehicle to log in to public HPC, DC, and AC charging stations automatically, as soon as the vehicle is connected to the charging station with the charging cable. Logging in manually and paying with a card or app will not be necessary. Plug & charge is only possible at compatible charging stations.

Configuration

Requirement: you must have an active vehicle charging plan that supports Plug & charge.

- Configure the Plug & charge function in the myAudi app.

Switching on and off

Only the key user can switch on Plug & charge. Once Plug & charge has been switched on, all users can charge using Plug & charge. Authorizing individual users to use Plug & charge is not possible. Any user can switch off the service, for example for an upcoming charging session. The key user must switch on the service again.

Requirement: you have configured Plug & charge. Your myAudi user is set as the key user of the vehicle ⇒ *page 32* and you are logged in as this user.

- Applies to: MMI: To switch Plug & charge on or off, select on the home screen: **VEHICLE > Charging > ⚙ > Plug & Charge.**

Charging and paying

- Select a charging station that is Plug & charge compatible. You can find information about Plug & charge compatibility in the myAudi app under the charging station payment options.
- Connect your vehicle to the charging station ⇒ *page 109, Connecting the charging cable.*
- Make sure that the login at the charging station was successful. The charging process will start automatically.
- Unplug the charging connector after the charging process is successfully completed ⇒ *page 109.* Payment will be processed automatically using the stored vehicle charging plan.

Erasing contract information from the vehicle

If the key user remains logged into the vehicle after the vehicle charging plan ends, the contract data will be automatically deleted from the vehicle.

If there still is an active charging plan, then unauthorized persons could use this function at your cost, for example if you sell your vehicle. To prevent this, you must delete the contract data from the vehicle.

- Reset the vehicle to the factory default settings.

Troubleshooting

If the function cannot be switched on or if you cannot enter a vehicle charging plan, then reset the vehicle to factory default settings and try again after 24 hours.

Messages**Plug & charge authentication not possible**

This message appears if authentication and payment via Plug & charge is not possible. To start a charging session anyway, select another payment method at the charging station. If the charging ▶

¹⁾ The function or equipment that is described was in development at the time this manual was published and may not be available in your vehicle.

process will still not begin, switch off Plug & charge and start the charging process again.

Advanced charging settings



Possible settings

With the advanced charging settings, you can define addresses (locations) at which certain charging settings should apply. These will be applied as long as your vehicle is near a specified address. The charging target that is set will be used both for immediate charging mode and timer charging mode.

Depending on the vehicle equipment, you can also adjust the following settings:

- ▶ Charging target (battery charge level at departure time, also see ⇒ *page 113*).
- ▶ Minimum charge (for example, to ensure a certain range when departing earlier).
- ▶ Preferred charging time (for example, to use a less expensive electricity rate).

Managing the advanced charging settings

- ▶ Applies to: MMI: Select on the home screen: **VEHICLE > Charging >  > Advanced charging settings**.
- ▶ To define new settings for a certain address, select +. Follow the instructions in the display.
- ▶ To edit existing settings for a certain address, press the respective button.
- ▶ To delete existing settings for a certain address, select .

Preferred charging time

If you activate this function, then the charging process will be limited to a charging time frame that you have set. If the charging time frame is too short, then the set charging target might not be reached. To make sure a certain charge level has been reached by your departure time, also activate a timer.

Preferred charging times will only be taken into consideration if you activate timer charging mode before the next charging process ⇒ *page 112*.

Tips

The following applies if automatic unlocking of the charging connector is activated: if the vehicle is not currently charging, then the charging connector is unlocked and can be disconnected, for example when waiting for a timer or a charging time frame.

Charging equipment

Introduction



Depending on the vehicle equipment, the Audi e-tron Charging System Compact may be available.

Using the charging equipment

Pay attention to the following information for safe handling of the charging equipment:

- Secure the charging equipment against any strain, such as being run over, falling, pulling, bending, and crushing.
- Do not submerge the charging equipment in water and do not cover it with snow or ice.
- When you remove the charging cable from the vehicle and from the power supply, only pull on the connectors and not on the cable.
- Put the cap on after using the charging cable.
- Only operate the Audi charging system in a power supply system with a frequency of 50 Hz/60 Hz.
- Only operate or store the Audi charging system at a humidity level between 5% and 95% (no condensation).
- The Audi charging system is protected against dust and splashing water (IP55 (USA: Enclosure 3)).

Depending on the country, different warnings may be on the charging equipment.

Symbol	Meaning
	Operate or store the Audi charging system at a temperature range of -22 °F (-30 °C) to +122 °F (+50 °C).
	Operate or store the Audi charging system at a maximum elevation of 13,000 feet (4,000 m) above sea level.

Symbol	Meaning
	Operate or store the Audi charging system at a maximum elevation of 16400 feet (5000 m) above sea level.
	The Audi charging system is not equipped with a connected ground conductor.
	The Audi charging system is equipped with a connected ground conductor.
	Do not operate the Audi charging system in power networks that are not grounded (such as IT networks). Only operate the Audi charging system in grounded power networks.
	Surfaces can become very hot when in direct sunlight.
	Incorrect use increases the risk of electric shock.
	Read and observe the applicable Owner's Manual, particularly the safety precautions.
	Pay attention to all applicable disposal regulations when disposing.
	Do not use any extensions cords or cable reels.
	Do not use any travel adapters.
	Do not use any power strips.
	Do not use any charging cables with damage to the electronics or the connecting wires.

Grounding instructions

Audi charging systems must be grounded. If it should malfunction or break down, grounding provides a path of least resistance for electric current to reduce the risk of electric shock. Audi charging systems are equipped with a cord having an equipment grounding conductor and a grounding plug. The plug must be plugged into an appropriate outlet that is properly installed and grounded in accordance with all local codes and ordinances.

WARNING

Improper connection of the equipment-grounding conductor is able to result in a risk of electric shock. Check with a qualified electrician or serviceman if you are in doubt as to whether the product is properly grounded. Do not modify the plug provided with the product – if it will not fit the outlet, have a proper outlet installed by a qualified electrician.

For the sake of the environment

Batteries and electrical/electronic devices must be disposed of in an environmentally safe manner ⇒ *page 291, Disposal instructions*.

Transporting



Fig. 86 Luggage compartment: transport compartment

Always store the charging equipment securely in the luggage compartment before transporting.

- ▶ Open the luggage compartment lid ⇒ *page 39*.
- ▶ Lift the luggage compartment floor and place the charging equipment in the transport compartment ①.

High-voltage system

If the charging equipment is transported outside the transport compartment, it needs to be secured in the luggage compartment correctly, for example with a cargo net.

WARNING

If the charging equipment is not secured or positioned correctly, it can slide out of place and endanger vehicle occupants when braking, when changing directions, or in a collision.

- Store charging equipment only in the luggage compartment, either inside the transport compartment or using other means of securing, such as a cargo net.
- Transporting the charging equipment in the passenger compartment is not permitted.

Note

Always lift or carry the Audi charging system as one unit and never by the cables.

Audi e-tron Charging System Compact

Applies to: vehicles with Audi e-tron Charging System Compact

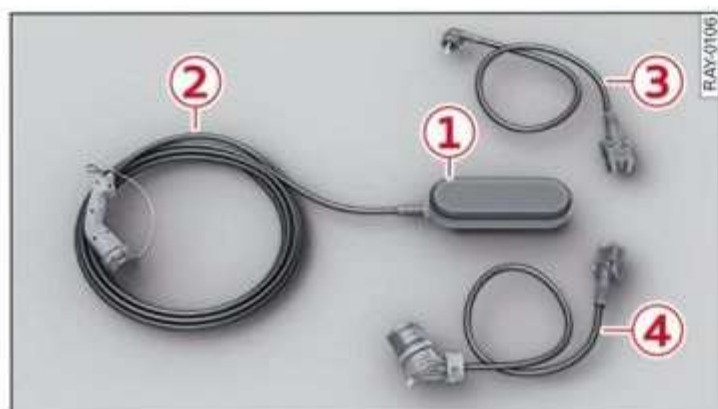

Fig. 87 Audi e-tron Charging System Compact: components (example)

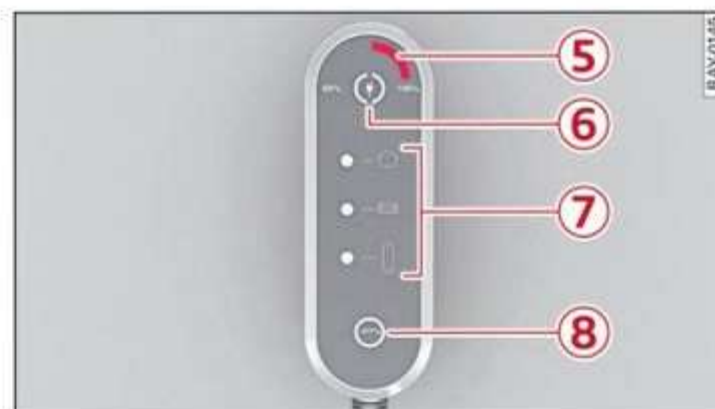

Fig. 88 Audi e-tron Charging System Compact: control unit





Observe the safety precautions ⇒ *page 107, Important safety precautions.*

The Audi e-tron Charging System Compact can be used for charging with a household or industrial socket. Depending on the country and the vehicle equipment, the following accessories may be available:

- ① Control unit
- ② Vehicle cable with vehicle charging connector
- ③ Power cable with power plug for household sockets
- ④ Power cable with power plug for industrial sockets

The vehicle cable is securely connected to the control unit. The power cable is plugged into the upper end of the control unit and can be switched ⇒ *page 123.*

Control unit overview

⑤ ^{a)}	Safety precaution: only set the charging power level to 100% if the charging infrastructure has been checked by a qualified electrician. Otherwise there is a risk of damage to the charging infrastructure, such as scorching ⇒ <i>page 107, Important safety precautions.</i>	
⑥	On/Off button (⏻), charging power level and LED	
⑦	Status LED:	
		Power supply/household connection
		Vehicle
⑧		Control panel
		Reset

a) In certain countries.

Charging

Note the instructions for charging ⇒ *page 109*.

Requirement: the correct power plug must be installed ⇒ *page 123*.

- Insert the plug into the socket.
- Plug the vehicle charging connector into the vehicle charging port.
- The charging process will start automatically.
- Once the charging process has completed, unlock the vehicle and remove the vehicle charging connector from the vehicle charging port.

Adjusting the charging power level



The charging power level setting can limit the charging current as well as the charging capacity. You can set whether you would like to charge with reduced (50%) or full (100%) charging power. The full charging power level (100%) ensures the shortest charging time and should only be used if the electrical installation has been checked by a qualified electrician. The reduced charging power level (50%) can reduce load on the electrical installation and prevent overheating or overloading the electrical installation, for example if several consumers are connected to the power circuit.





Note the following points about the charging power level:

- When using a household socket, the last level that was set will always be stored and used again the next time the vehicle is charged.
- If the power supply to the charging system is interrupted (for example by disconnecting the plug), then the charging power level will be reset to 50% when using an industrial connector.

















The vehicle has a minimum battery charging capacity of 880 W. Therefore, if the network voltage is less than 200 V, charging using a household socket will only be possible if the charging power level is set to 100%. Otherwise, the charging process will not start.

































Before charging, always check if the charging power setting that was selected last is still suitable.































- To set the charging power level, press and hold the  button  ⇒ *fig. 88* for at least two seconds.































After the charging power level is set, the status LEDs ,  and  will flash green one time. The selected value (50% or 100%) is displayed on the left or right side of the  button.

Control unit: status and malfunction indicators

Indicator lights	Meaning	Solution
 Green  Off  Off  Off  Off	The charger is ready to charge, but is not charging.	Starting the charging process ⇒ <i>page 109</i> .
 Flashing green  Off  Off  Off  Off	The vehicle is being charged with the ground conductor monitor activated.	
 Flashing green  Yellow  Off  Off  Off  Off	The power cable has overheated. Possible cause of the malfunction: a multi-phase socket is being used in single-phase mode. The charging performance will be reduced.	After the cable cools down, the malfunction will be automatically cleared. Until it cools down, charging performance will be reduced. If the malfunction continues, have the power supply/household connection checked by a qualified electrician.

Indicator lights	Meaning	Solution
 Flashing green  Off  Off  Yellow  Off	The control unit has overheated. The charging performance will be reduced.	After the control unit cools down, the malfunction will be automatically cleared. Never leave the control panel in direct sunlight for long periods or time. Until it cools down, charging performance will be reduced. If the malfunction continues, have the control unit checked by an authorized Audi dealer or authorized Audi Service Facility.
 Yellow  Off  Off  Off  Off	The charger is connected to the vehicle. The high-voltage battery is charged and the charging process has ended successfully, or the vehicle is not requesting a charging procedure.	
 Red  Yellow  Off  Off  Off  Off	The power cable has overheated. The charging process has been interrupted.	After the cable cools down, the malfunction will be automatically cleared and the charging process will resume. If the malfunction continues, have the control unit checked by an authorized Audi dealer or authorized Audi Service Facility, or have the power supply/household connection checked by a qualified electrician.
 Red  Off  Off  Yellow  Off	The control unit has overheated. The charging process has been interrupted.	After the control unit cools down, the malfunction will be automatically cleared and the charging process will resume. Never leave the control panel in direct sunlight for long periods or time. If the malfunction continues, have the control unit checked by an authorized Audi dealer or authorized Audi Service Facility.
 Red  Flashing yellow  Off  Off  Off  Off	The charging infrastructure of the power supply/household connection is restricted. Possible cause of the malfunction: low voltage or poor power frequency. The charging process has been interrupted.	After the power supply/household connection stabilizes, the malfunction will be automatically cleared and the charging process will resume. If the malfunction continues, have the power supply/household connection checked by a qualified electrician.
 Red  Off  Flashing yellow  Off  Off	There is a malfunction in the vehicle charging system. The charging process has been interrupted.	After the vehicle charging system stabilizes, the malfunction will be automatically cleared and the charging process will resume. If the malfunction continues, have the vehicle checked by an authorized Audi dealer or authorized Audi Service Facility.

Indicator lights	Meaning	Solution
 Red  Off  Off  Flashing yellow  Off	The power cable or vehicle cable is faulty. Possible cause of the malfunction: the coding resistance of the power or vehicle cable is not compatible. The charging process has been interrupted.	Have the power or vehicle cable replaced by an authorized Audi dealer or authorized Audi Service Facility.
 Red  Off  Red  Off  Off	There is a malfunction in the vehicle charging system. The charging process has been interrupted.	End the charging process at the vehicle and remove the vehicle cable from the vehicle charging port. Disconnect the charger from the power supply and reconnect it after 60 seconds. Restart the charging process ⇒ <i>page 109</i> . If the malfunction continues, have the vehicle checked by an authorized Audi dealer or authorized Audi Service Facility.
 Red  Flashing red  Off  Off  Off  Off	There is an overvoltage in the charging infrastructure of the power supply/household connection. The charging process has been interrupted.	Disconnect the charger from the power supply and reconnect it after 60 seconds. If the malfunction continues, have the power supply/household connection checked by a qualified electrician.
 Red  Off  Off  Red  Off	The control unit has a technical malfunction. The charging process has been interrupted.	Disconnect the charger from the power supply and reconnect it after 60 seconds. If the malfunction continues, have the control unit checked by an authorized Audi dealer or authorized Audi Service Facility.
 Red  Off  Off  Flashing red  Off	The control unit has a technical malfunction (self-test failed). The charging process has been interrupted.	Disconnect the charger from the power supply and reconnect it after 60 seconds. If the malfunction continues, have the control unit checked by an authorized Audi dealer or authorized Audi Service Facility.
 Red  Red  Red  Off  Off	The charging infrastructure of the power supply/household connection is insufficient: the ground conductor is interrupted or not present. The ground conductor monitor has interrupted the charging process.	Have the control unit checked by an authorized Audi dealer or authorized Audi Service Facility, and have the power supply/household connection checked by a qualified electrician. Do not use the power supply/household connector until the malfunction is corrected.

Indicator lights	Meaning	Solution
 Red  Red  Red  Red  Off	The indicator light in the reset button on the control unit is faulty. The charging process has been interrupted.	Have the control unit replaced by an authorized Audi dealer or authorized Audi Service Facility.
 Red  Red  Red  Red  Flashing red	The control unit has detected residual current. The charging process has been interrupted.	Press and hold the  button for at least two seconds. If the malfunction continues, have the control unit checked by an authorized Audi dealer or authorized Audi Service Facility, and have the power supply/household connection checked by a qualified electrician.
 Red  Flashing red  Flashing red  Flashing red  Off	The charging infrastructure is wired incorrectly. The charging process has been interrupted.	Disconnect the charger from the power supply. Have the power supply/household connection checked by a qualified electrician.
 Red  Red  Red  Red  Red	The control unit has a technical malfunction. Possible cause of the malfunction: software error or the load relay has been switched incorrectly. The charging process has been interrupted.	Disconnect the charger from the power supply and reconnect it after 60 seconds. If the malfunction continues, have the control unit checked by an authorized Audi dealer or authorized Audi Service Facility, and have the power supply/household connection checked by a qualified electrician.
 Flashing red  Off  Off  Red  Off	The control unit has a serious malfunction. The charging process has been interrupted.	Have the control unit replaced by an authorized Audi dealer or authorized Audi Service Facility.
 Off  Red  Red  Red  Red	The indicator light in the On/Off button on the control unit is faulty. The charging process has been interrupted.	Have the control unit replaced by an authorized Audi dealer or authorized Audi Service Facility.

Technical Data

The output of the charging system may be different from the charging rate of your vehicle. Cer-

tain factors, such as fluctuations in the system voltage, may also influence the output of the charging system ⇒ *page 107*.

Max. output	9.6 kW
Current rating	40 A single phase
System voltage	120 V – 240 V

Power frequency	50 Hz/60 Hz
Overvoltage category (IEC 60664)	II
Short-time current rating (EN 61439-1)	<10 kA eff.
Power plug versions	NEMA 6-30; NEMA 6-50; NEMA 14-30; NEMA 14-50; NEMA 5-15
Integrated residual-current device	AC: 20 mA; DC: 56 mA
Vehicle charging connector	Type 1
Protection class	I
IP Code	55 (USA: Enclosure 3)
Control unit mass	5.3 lbs – 7.7 lbs (2.4 – 3.5 kg)
Control unit dimensions (height x width x depth)	12.2 in x 4.1 in x 2.8 in (310 mm x 105 mm x 72 mm)

i Tips

- The device runs a self test after power has been restored to the control unit. If a self test is successful, all indicator lights will illuminate green for two seconds.
- The Audi e-tron Charging System Compact is designed for charging at sockets with a voltage of 120 V/240 V. If your socket has a different voltage, contact and authorized Audi dealer or authorized Audi Service Facility.
- If your Audi e-tron Charging System Compact has a fixed connection, meaning it can be connected directly to the power supply without a power cable, contact a qualified electrician or an authorized Audi dealer or authorized Audi Service Facility.
- The system complies with United States FCC regulations and ISED regulations ⇒ *page 291*.

Changing or attaching the cable

Applies to: vehicles with Audi charging system

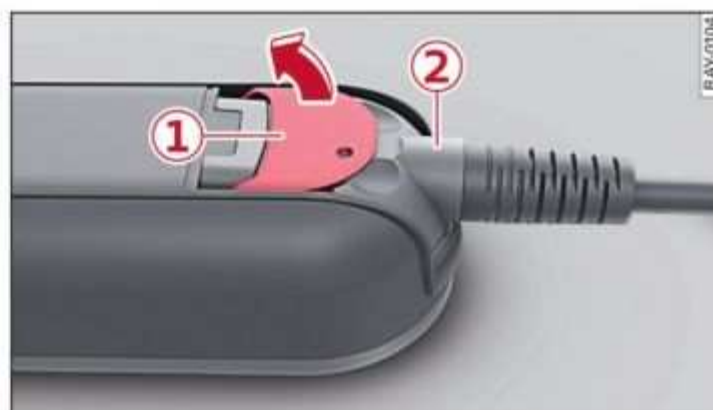

Fig. 89 Control unit: removing and attaching the cable

Requirements:

- ▶ The charging process for the high-voltage battery must be ended ⇒ *page 109*.
- ▶ The vehicle charging connector must be removed from the vehicle charging port.
- ▶ The power cable must be removed from the socket.

Loosening the cable

- ▶ Lift the lever ① all the way up.
- ▶ Pull the connector ② out just until you feel resistance.
- ▶ Close the lever ① until it is resting on the connector ②.
- ▶ Remove the connector ② completely.

Attaching the cable

- ▶ Lift the lever ① up slightly. ▶

- ▶ Insert the connector ② into the control unit just until you feel resistance.
- ▶ Lift the lever ① all the way up.
- ▶ Insert the connector ② all the way into the control unit.
- ▶ Close the lever ①.

WARNING

- Note the warnings for charging ⇨  in *Charging on page 110*.
- Before switching a cable, always unplug the power cable from the socket.
- Only change cables in a dry environment.
- The Audi charging system may only be used as a complete unit consisting of the power cables, the control unit, and the vehicle cable. Depending on the country, the total length of the power cable, control panel, and vehicle cable may be restricted, for example to 24.6 feet (7.5 m) in the USA. Audi recommends using only cables approved by Audi.

Tips

- The power cable with the power connector for industrial sockets and the Audi charging system control unit are designed to work together. Changing the power cable to another connector type may reduce the available charging power of the entire system. Limitations on the ability to transfer power (current capacity) depending on the phase and the number of available phases may affect the available charging power.
- To reduce the risk of theft of the charging equipment and cable, the lever on the control unit can be secured with a bolt to deter theft. For more information on this, contact an authorized Audi dealership.

Wall mount clip

Applies to: vehicles with wall mount clip



Fig. 90 Wall mount clip: securing the Audi charging system

Securing the Audi charging system

- ▶ First insert the control unit in the bottom tabs on the wall mount clip and then into the upper tabs.
- ▶ Push the control unit in the direction of the arrow toward the rear ⇨ *fig. 90* and let it lock into place.
- ▶ Wrap the excess length of cable around the charging connector mount ① when you are not charging the high-voltage battery.
- ▶ Plug the power cable into the socket ②.
- ▶ After charging, you can hook the vehicle charging connector to the charging connector mount ①.

Locking and unlocking the Audi charging system

- ▶ Lock or unlock the Audi charging system if necessary using the key provided by turning it to the lock position ④ or the unlock position ⑤.

Removing the Audi charging system

- ▶ Remove the power cable connector from the socket ②.
- ▶ Unwind the cable from the charging connector mount ①.
- ▶ To loosen the control unit from the bracket, push the locking mechanism ③ upward.

WARNING

Observe the safety precautions in the assembly instructions for the wall mount clip.

Trailer towing

Driving with a trailer

General information

Your vehicle is primarily intended for transporting people and luggage. However, if you drive with a trailer, follow the technical requirements, the operation and driving tips, and the legal regulations.

Driving with a trailer affects the vehicle's energy usage, performance, and wear. It also requires greater concentration.

A retrofitted trailer hitch must be installed according to the instructions provided by the manufacturer ⇒ *page 127*.

WARNING

- Do not transport any people in a trailer due to the risk of fatal injury.
- Only use a ball hitch that is approved for your vehicle. Using a ball hitch that is not approved for your vehicle can lead to issues such as unstable driving behavior or uncoupling of the trailer and increase the risk of an accident. If you have questions, see an authorized Audi dealer or authorized Audi Service Facility.

Operating instructions

Towing capacity

The permitted towing capacity must not be exceeded under any circumstances ⇒ *page 290*.

You can drive up larger inclines if you are not using the maximum towing capacity.

Tongue weight

The maximum permitted tongue weight of the trailer drawbar on the trailer hitch ball head must not be exceeded.

For driving safety, Audi recommends always using the maximum permitted tongue weight, but do not exceed this weight. Having the tongue weight too low affects the handling of the vehicle and trailer.

You can determine the tongue weight using a tongue weight scale, a bathroom scale, or a public weigh station, for example. Audi recommends checking the tongue weight, especially when towing double axle trailers. If the tongue weight differs, it can be adjusted by distributing the load in the trailer correctly. If the tongue weight meets the specifications, then the load on the trailer should not be changed anymore.

Load distribution

Poor cargo load and distribution can negatively impact vehicle handling. Load the vehicle and trailer based on the following criteria as much as possible:

- Store objects in the vehicle luggage compartment, if possible. The vehicle should always carry the heaviest possible load and the trailer should have the lightest possible load.
- Distribute the load in the trailer so that the heavy objects are as close to the axle as possible.
- Secure objects so that they do not slide.
- Utilize the maximum permitted tongue weight if possible.

Speed

Adhere to the legal speed limits. Follow the legal regulations that are applicable in the country where you are operating the vehicle.

As the speed increases, the driving stability of the vehicle and trailer decreases. Therefore you should not exceed the maximum legal speed limit when there are unfavorable road, weather, and/or wind conditions. This especially applies when driving downhill.

Hill

When you start driving uphill or downhill, the vehicle and trailer may tilt or sway sooner than when driving on a level surface. If small swaying movements have already occurred, you can stabilize the trailer by firmly braking immediately. Never attempt to "straighten out" the vehicle and trailer by accelerating.

reduce the speed and use the recuperation braking effect ⇒ *page 93* to relieve the brakes ⇒  ►

Exterior lighting

Follow the legal regulations for lighting on your trailer that are applicable in the country where you are operating the vehicle. If necessary, contact an authorized Audi dealer or authorized Audi Service Facility for more information.

Before you start driving, check all lighting equipment on the trailer while it is hitched to the vehicle.

The headlight range control automatically adjusts the light range of the headlights.

When the  indicator light blinks, then the turn signals are activated in trailer mode. If a turn signal on the trailer or on the vehicle fails while in trailer mode, the indicator light will **not** blink twice as fast to indicate this.

Outside mirrors

Make sure that you can also observe the traffic area behind the vehicle using the exterior mirrors, and use additional exterior mirrors if necessary. Adjust the additional exterior mirrors so that you have a sufficient visibility behind the vehicle. Follow the local legal regulations for installing additional exterior mirrors.

Tires

Set the tire pressure on your vehicle for a "full load"; see the tire pressure sticker ⇨ *page 252*. If necessary, also adjust the tire pressure on the trailer according to the manufacturer's specifications.

The trailer and the vehicle should be equipped with winter tires when driving in winter temperatures.

Overrun brakes

If your trailer is equipped with an overrun brake, it must be correctly adjusted and function correctly. When using a trailer with overrun brakes, first brake gently then quickly. This reduces the risk of jerking while braking if the trailer wheels lock up.

WARNING

Constant braking causes the brakes to overheat and can substantially reduce braking performance, increase braking distance, or cause complete failure of the brake system.

Note

Attachments retrofitted on the vehicle may cause damage, especially on the trailer hitch ball head. In cases of damage, have the function checked by an authorized Audi dealer or authorized Audi Service Facility.

Tips

- Block the wheels with chocks when parking on inclines if the trailer is loaded.
- Audi recommends having the vehicle inspected between the inspection intervals if you tow a trailer frequently.

Trailer hitch

Introduction

Only use a trailer hitch with a removable ball hitch mount and ball hitch. The trailer hitch must be permitted for the vehicle, the trailer and the permitted total weight of the trailer being pulled. Above all, it must be securely and safely attached to the vehicle trailer.

Never mount a trailer hitch on the bumper. The trailer hitch must be mounted in a way that does not impair the function of the bumper. Do not make any modifications to the brake system.

Check regularly if the trailer hitch is securely mounted. Always follow the instructions given by the trailer hitch manufacturer.

WARNING

Never mount a "weight-distributing" or "load-balancing" trailer coupler as the trailer hitch. The vehicle was not designed for these types of trailer hitches. The trailer hitch can malfunction and the trailer can separate from the vehicle, which increases the risk of an accident.

Using the trailer hitch

Applies to: vehicles with trailer hitch

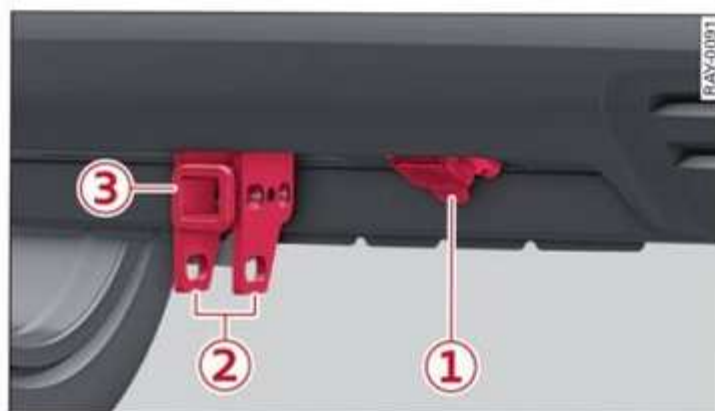

Fig. 91 Rear bumper: trailer hitch

The trailer hitch of your vehicle consists of the receiver ③, the connector¹⁾ ① or connector retainers, and two eyelets ② for the safety chains.

The receiver ③ is suitable for securing a removable ball hitch mount with a ball head, for example when towing a trailer ⇒ ⚠.

- ▶ Check the receiver ③ for dirt and clean it if necessary.
- ▶ When towing a trailer, use the trailer connector¹⁾ ① and secure the safety chains using the eyelets ②.

⚠ WARNING

- For your own safety, read the installation instructions provided by the ball hitch mount manufacturer.
- There is a risk of an accident if the ball hitch mount is installed incorrectly. The ball hitch mount must be secured in the receiver ③ correctly. The same applies to accessories that are secured in the receiver.
- Only use a ball hitch mount with ball head suitable for your vehicle and your trailer.
- To reduce the risk of injury, always remove the ball hitch mount if no trailer is mounted.
- To reduce the risk of an accident, contaminants on the trailer hitch must be removed because otherwise the ball hitch mount might not be secured correctly in the receiver.

i Tips

- No ball hitch mount or ball head is provided with the trailer hitch. You can purchase these at specialty stores.
- The eyelets on the trailer hitch are only intended for securing the trailer safety chains.

Driving with a trailer

Trailer brakes

If the trailer has its own brake system, then follow the manufacturer specifications. However, the brake system on the trailer must never be connected to the vehicle brake system.

Safety chains

Make sure the safety chains are correctly applied when pulling a trailer. The chains should hang enough so that the trailer can drive around curves. However, they must not touch the ground.

⚠ WARNING

If the trailer is equipped with electronic brakes, these brakes cannot be activated by a factory-installed control system, which increases the risk of an accident.

Retrofit installation

You can find out if your vehicle is equipped with a retrofitted trailer hitch at an authorized Audi dealer or authorized Audi Service Facility.

An authorized Audi dealer or authorized Audi Service Facility knows the specifications for retrofitting a trailer hitch and any necessary technical requirements.

⚠ WARNING

- Only have the additional trailer hitch installed by an authorized Audi dealer or authorized Audi Service Facility.
- There is a risk of an accident if the trailer hitch is installed incorrectly.

¹⁾ In certain countries.

- For your own safety, read the assembly instructions provided by the trailer hitch manufacturer.

 **Note**

Connecting the socket incorrectly could cause damage to the vehicle electrical system.

Assist systems

General information

Safety precautions

Observe the safety precautions for the assist systems, sensors, and cameras ⇨ .

WARNING

- As the driver, you have complete responsibility for all driving operations at all times. The assist systems cannot replace the driver's attention. Give your full attention to driving the vehicle, and be ready to intervene in the traffic situation at all times.
- Activate the assist systems only if the surrounding conditions permit it. Always adapt your driving style to the current visual, weather, road, and traffic conditions.
- Loose objects can be thrown around the vehicle interior during sudden driving or braking maneuvers, which increases the risk of an accident. Store objects securely while driving.
- For the assist systems to be able to react correctly, the function of the sensors and cameras must not be restricted. Note the information on sensors and cameras ⇨ *page 130*.

Tips

- Pay attention to applicable local regulations relating to driving tasks, leaving space for emergency vehicles, vehicle distance, speed, parking location, wheel placement, etc. The driver is always responsible for following the laws that are applicable in the location where the vehicle is being operated.
- You can cancel a steering or braking intervention by the system by braking or accelerating noticeably, steering, or deactivating the respective assist system.
- Always check the assist systems settings before driving. The settings may have been changed, for example by switching off the ignition or by other persons.

System limitations

Observe the limits of the assist systems, sensors, and cameras ⇨ .

WARNING

- The use of an assist system cannot overcome the natural laws of physics. A collision cannot be prevented in certain circumstances.
- Warnings, messages, or indicator lights may not be displayed or initiated on time or correctly, for example, if vehicles are approaching very fast.
- Corrective interventions by the assist systems, such as steering or braking interventions, may not be sufficient or they may not occur. Always be ready to intervene.

Tips

- Due to the system limitations when detecting the surrounding area, the systems may warn or intervene unexpectedly or too late in certain situations. The assist systems may also interpret a driving maneuver incorrectly and then warn or intervene unexpectedly.
- The systems may not function as expected in unusual driving situations, such as driving offroad, on unpaved roads, on loose ground, on inclines, or on grooves in the road.
- The systems may not function correctly in unclear traffic situations, such as turning lanes, exit ramps, construction zones, rises or dips that obstruct visibility, intersections, toll stations, or city traffic.
- The detection of the surrounding area can be limited, for example by vehicles driving ahead or by rain, snow, heavy spray, or light shining into the camera.
- In trailer mode, some assist systems may be limited, may not react as usual, or may be unavailable. Please refer to the instructions for towing a trailer located in ⇨ *page 125*.
- The steering wheel touch recognition may be limited when you wear gloves. Steering intervention requests from the steering assist systems may occur more frequently.

– If accessories have been mounted on the steering wheel, the steering assist systems may be limited. The frequency of steering intervention requests from the steering assist systems may vary as well.

Surrounding area detection

Sensor and camera coverage areas

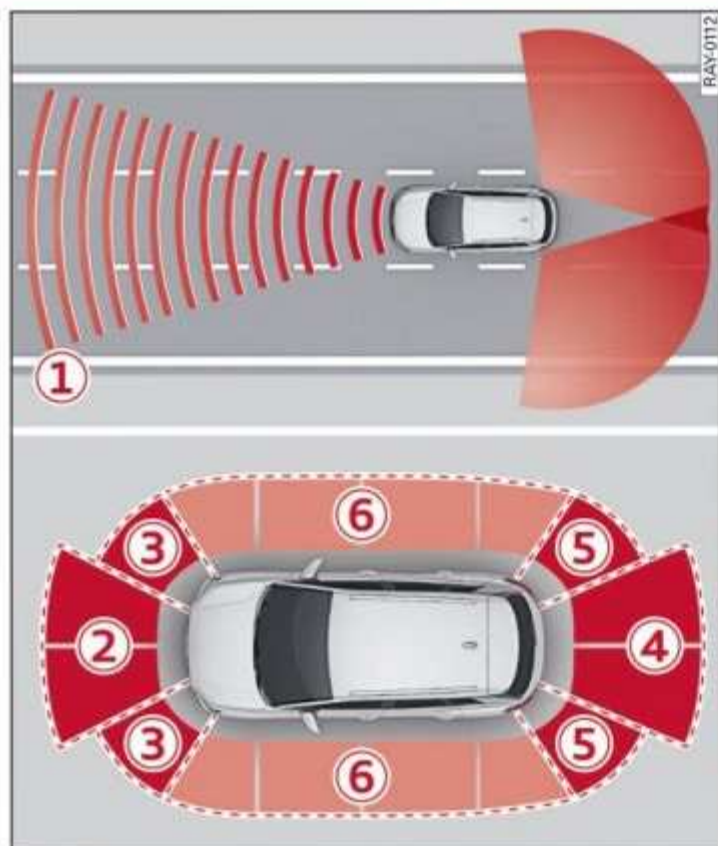

Fig. 92 Sensor detection ranges



Fig. 93 Rearview camera coverage area

The assist systems analyze the data from various sensors and cameras installed in the vehicle. Do not use any assist systems if there is damage in the area of the sensors and cameras or on the ve-

hicle underbody. Damage can impair the function of the sensors and cameras or cause malfunctions. Have an authorized Audi dealer or authorized Audi Service Facility check their function.

Radar sensors

Depending on the vehicle equipment, the area in front of and behind the vehicle may be detected ⇒ fig. 92 ①.

The wheel sensors on the rear corners of the vehicle are positioned so that the adjacent lanes to the left and right are detected on roads with a normal lane width.

Ultrasonic sensors

Depending on vehicle equipment, various areas may be displayed in the MMI using the ultrasonic sensors ⇒ fig. 92.

The range of the displays depends on the location of the ultrasonic sensors:

- ② Approximately 4 feet (1.20 m)
- ③ Approximately 3 feet (0.90 m)
- ④ Approximately 5.2 feet (1.60 m)
- ⑤ Approximately 3 feet (0.90 m)
- ⑥ Approximately 3 feet (0.90 m)¹⁾

The side area ⑥¹⁾ is detected and evaluated when passing. There may have been changes to the surrounding area after switching the ignition off and on again, after opening the doors, or if the vehicle is left stationary for a period of time. In this case, the area will appear black until the area has been detected and evaluated.

Cameras

Use the camera image on the display to assist you only if it shows a good, clear picture. Keep in mind that the image in the display is enlarged and distorted. Under certain circumstances, objects may appear different and unclear on the display.

The rearview camera can only detect the area marked in red ⇒ fig. 93. Only this area is displayed on the center display ⇒ ⚠.

¹⁾ In preparation at the time of printing.

! WARNING

- Sensors and cameras have spots in which the surrounding area cannot be detected. Objects, animals, and people may only be detected with limitations or may not be detected at all. Always monitor the traffic and the vehicle's surroundings directly and do not become distracted.
- Sensors may be subject to physical system limitations. External sources of interference, for example from other vehicles, can impair sensor functionality. The assist systems may be limited or may not function as expected.

! Note

- Obstacles may disappear from the measurement range when approaching them, even if they were already detected.
- In some situations, the ability of the sensors and cameras to detect and display certain objects may be limited.
 - Objects located above the coverage area, such as bumpers on parked cars, garage doors that are partially open, or objects that are hanging
 - Low obstacles
 - Narrow objects, such as barrier chains, foliage, poles, or fences
 - Projecting objects, such as trailer draw bars
 - Objects with certain surfaces and structures, such as fabric

i Tips

- The radar sensors are calibrated once when driving the first few miles after delivery of the vehicle, as well as after repairs to the sensor system. During the calibration period, the sensor range may be limited.
- The sensors and cameras and the areas around them must not be obstructed because this can impair the function of the systems that depend on them. Make sure that the sensors and cameras are free of snow, ice, and other deposits. Attachments, stickers, adhesive, or similar objects must

not extend into the visual field of the sensors and cameras.

- On vehicles that have factory-installed license plate brackets on the front of the vehicle, the brackets may only be replaced with ones that are the same size and made of the same material. Do not install any license plate brackets on the front of vehicles that do not have factory-installed brackets. Otherwise, the function of the system could be impaired.
- The function of the sensors and cameras may be limited when light and visibility conditions are poor, for example when driving into a tunnel, when there is glare, or when there are reflective objects.
- External ultrasonic sensors, such as those in other vehicles, can interfere with the sensors.
- The coverage areas of the sensors ⇒ *fig. 92* and cameras ⇒ *fig. 93* are diagrams and do not represent a true-to-scale image of the sensor ranges.
- The system complies with United States FCC regulations and ISED regulations ⇒ *page 291*.

Locations of the sensors and cameras

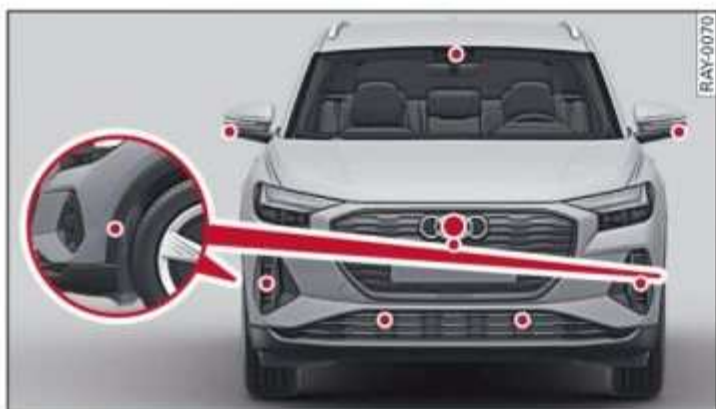

Fig. 94 Front area: sensors and cameras



Fig. 95 Rear area: sensors and cameras

Front area

Depending on the vehicle equipment, the following sensors and cameras may be installed:

- Camera behind the windshield
- Peripheral cameras on the exterior mirrors
- Front peripheral camera in the radiator grille
- Front and side ultrasonic sensors¹⁾
- Front radar sensor in the center of the radiator grille

Rear area

Depending on the vehicle equipment, the following sensors and cameras may be installed:

- Rearview camera in the luggage compartment lid
- Radar sensors at the rear corners of the vehicle
- Rear and side ultrasonic sensors¹⁾

i Tips

- The locations of the sensors may differ slightly depending on vehicle equipment.

- Some sensors are installed under vehicle components and cannot be seen from the outside.
- The system complies with United States FCC regulations and ISED regulations
⇒ page 291.

Driver assistance menu



Fig. 96 Center console: driver assistance systems button

In the **Driver assistance** menu, you can turn certain assist systems on or off, or adjust them to your preferences.

- ▶ Press the button ①, or
- ▶ Applies to MMI: Select on the home screen: **VEHICLE > Driver assistance**.

You can turn certain systems on/off by pressing or adjust them to your preferences .

! WARNING

Observe the safety precautions and note the limits of the assist systems, sensors, and cameras ⇒ page 129 to ⇒ page 132.

¹⁾ In preparation at the time of printing.

Parking aid menu



Fig. 97 Center console: parking aids button

In the **Parking aid** menu, you can turn certain parking aids on or off or adjust them to your preferences.

- ▶ Applies to MMI: Select on the home screen: **VEHICLE > Parking aid**, or
- ▶ Press the button ① in the center console and press  in the center display when the parking system is active.

You can turn certain systems on/off by pressing  or adjust them to your preferences.

Possible settings

The possible settings depend on the vehicle equipment. Some settings are only available via  and under certain conditions.

- **Automatic activation** ⇒ page 161
- **Front and rear volume** ⇒ page 162
- **Entertainment fader** ⇒ page 162.
- **Clean rearview camera** ⇒ page 164
- **Trailer view** ⇒ page 165
- **View** ⇒ page 166
- **Rear cross-traffic assist** ⇒ page 167

WARNING

Observe the safety precautions and note the limits of the assist systems, sensors, and cameras ⇒ page 129 to ⇒ page 132.

Driving information

Speed warning system

Description

Applies to: vehicles with speed warning system

The speed warning system helps to stay below a specified maximum speed. A warning threshold can be set in the MMI for this purpose.

Once the speed slightly exceeds the stored threshold, the speed warning system will provide an alert using an indicator in the instrument cluster and a warning tone. Once the speed drops below the stored maximum speed, the indicator will turn off.

Setting a threshold is recommended if you would like to be reminded when you reach a certain maximum speed. Situations where you may want to do so include driving in a country with a general speed limit or if there is a specified maximum speed for winter tires.

Tips

Regardless of the speed warning system, you should always monitor your speed using the speedometer and make sure you are adhering to the legal speed limit.

Setting the warning threshold

Applies to: vehicles with speed warning system

You can adjust the warning threshold to your preferences in the **Driver assistance** menu ⇒ *page 132*. The settings depend on the vehicle equipment.



Possible settings:

Speed warning – adjust the speed for the warning threshold.

Messages

Applies to: vehicles with speed warning system

The following messages may appear depending on the vehicle equipment:

 /  **Manually set XX warning threshold exceeded**

The stored speed was exceeded.

Camera-based traffic sign recognition

Description

Applies to: vehicles with camera-based traffic sign recognition



Fig. 98 Instrument cluster: traffic sign recognition

The traffic sign recognition shows the traffic signs detected by the front camera in the instrument cluster display and in the head-up display*. Data from the navigation system is also included in the display. Up to three traffic signs can be displayed in the instrument cluster at once. The speed limit that is currently applicable is displayed in the status bar. If necessary, it will be hidden if the system detects that turning right is prohibited at a red light. The display in the head-up display* can be switched off ⇒ *page 26*.

Within the limits of the system and depending on the market, speed limit restrictions ① in school zones, highways, construction zones, or at night may be displayed.

Limitations

The traffic sign recognition is subject to certain system limitations and may be unavailable or only partially available in the following situations:

- When visibility is poor, such as in snow, rain, fog, or heavy spray
- When there is glare, for example from oncoming traffic or the sun
- At high speeds
- If the camera's visual field ⇒ *page 130* is covered, for example by dirt or stickers. For information on cleaning, see ⇒ *page 261*.

- If the traffic signs are completely or partially covered, for example by trees, snow, dirt, or other vehicles
- If traffic signs do not conform to the standard format
- If traffic signs are damaged or bent
- If traffic signs are displayed on sign holders with electronic signs
- If the traffic signs or the roadways have changed, and the navigation data is no longer up-to-date

WARNING

- Observe the safety precautions and note the limits of the assist systems, sensors, and cameras ⇒ *page 129* to ⇒ *page 132*.
- Under some circumstances, traffic sign recognition may not detect traffic signs correctly or detect them at all. As a result, the system may not display the correct speed limit or any speed limit.

Tips

- Traffic sign recognition only informs and warns about speed limits. Depending on the vehicle equipment, additional driver assistance systems can adjust the vehicle speed.
- The display in the instrument cluster is based on the units of measurement used for speed in the country where the vehicle is being operated. As a result, a display of **50** in the instrument cluster can mean either mph or km/h, depending on the country.

Operation

Applies to: vehicles with camera-based traffic sign recognition

Accessing traffic sign recognition

- ▶ Select in the instrument cluster: vehicle functions tab > **Traffic signs**.

Setting a traffic sign based speed warning

You can adjust the speed warning threshold to your preferences in the **Driver assistance** menu ⇒ *page 132*. The settings depend on the vehicle equipment.

Possible settings:

Speed warning – you can select a warning threshold. If you exceed this, then the current detected speed limit will be shown in the display with an exclamation point for the duration that it is exceeded and it will blink for a short time.

Messages

Applies to: vehicles with camera-based traffic sign recognition

The following messages may appear depending on the vehicle equipment:

 **Traffic sign recognition: currently unavailable. Camera view restrict. due to environm. conditions**

The camera's visual field is covered. Clean the windshield.

 **Traffic sign recognition: currently limited. See owner's manual**

This message appears if navigation system data is not available, for example on newly-constructed roads. The speed limit display will be temporarily limited, which increases the risk of an incorrect display. If this message continues to appear, drive immediately to an authorized Audi dealer or authorized Audi Service Facility to have the malfunction repaired.

No traffic sign information available

Depending on the area, there is no valid navigation data and no speed limits were detected. This may also appear if there is a recommended speed, but no speed limit (for example when driving on and off the expressway).

Malfunction! See owner's manual

The system may not function correctly so it has been switched off. See an authorized Audi dealer or authorized Audi Service Facility for assistance.

Function currently unavailable. See owner's manual

If this message appears on vehicles without camera-based traffic sign recognition, then the traffic light information function is currently unavailable. See ⇒ *page 137*.

Traffic light information

Description

Applies to: vehicles with traffic light information

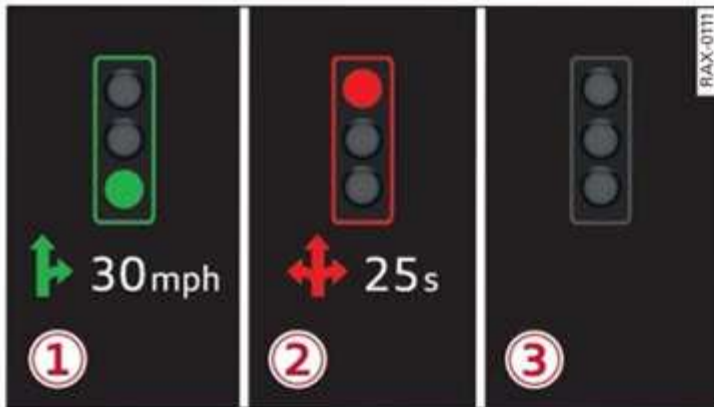

Fig. 99 Instrument cluster: traffic light information display

The traffic light information gives you a speed recommendation in order to reach the next traffic light when it is green ①, or it informs you of the wait time at the next red light ②. Once traffic light data is received, the traffic light information will be displayed in the instrument cluster and in the head-up display*. If the vehicle is in an area with traffic light information but cannot receive a traffic light signal, then a gray traffic light symbol will be displayed ③.

General information

The traffic light information is subject to system limitations and may be unavailable or only partially available in the following situations:

- If the permitted speed limit is exceeded
- If driving below a certain speed limit
- If the next traffic light is less than approximately 100 feet (30 m) away
- If the estimated wait time at a red light is less than four seconds
- If there is no traffic light data available
- If emergency response vehicles or public transit systems are active
- If traffic lights are in construction zones or being serviced
- If there are warnings from the camera-based traffic sign recognition*
- If the camera-based traffic sign recognition* is malfunctioning or not available
- If the data connection has been interrupted

- If data transmission is deactivated in the privacy settings
- If the subscription has expired

If this is the case, the menu item will be grayed-out or it will not be possible to select it.

⚠ WARNING

- When traffic light information is shown, also always pay attention to the traffic situation, the distance to other vehicles, and the area around the vehicle. The driver is always responsible for assessing the traffic situation.
- Always adapt your speed to the current weather, road and traffic conditions. The displayed information must never cause you to ignore legal traffic regulations and pose a safety risk.
- Regardless of the traffic light information, you should always monitor your speed using the speedometer and make sure you are adhering to the legal speed limit.
- The traffic light information does not adjust your vehicle's speed to the speed recommendation shown in the display.
- Observe the safety precautions and note the limits of the assist systems, sensors, and cameras ⇒ *page 129* to ⇒ *page 132*.

i Tips

- Traffic light information was not available in all countries at the time this manual was printed.
- Traffic light information was only available in select cities at the time this manual was printed.
- Traffic light information is not available nationwide.
- The functions depend on the navigation data* being up-to-date and correct identification by the traffic sign recognition*.
- Incorrect values from the camera-based traffic sign recognition* or outdated navigation system* map data can result in missing or incorrect display images.
- Certain traffic lights can automatically adjust to the current traffic situation. If this

occurs, the display of traffic light information can change suddenly.

- The traffic signs on the road always take priority over the display. The driver is always responsible for adhering to the regulations applicable in the country where the vehicle is being operated.
- Units of measurement and language settings are displayed based on how they were set in the MMI system settings ⇒ *page 225*.

- Traffic light information is switched off
- Data transmission is deactivated
- The vehicle is not equipped with traffic sign recognition.
- There is no valid license
- Traffic light information is not available in that area

Operation

Applies to: vehicles with traffic light information

Switching traffic light information on and off

You can turn the traffic light information on or off in the **Driver assistance** menu ⇒ *page 132*.

Accessing traffic light information

- ▶ Select in the instrument cluster: vehicle functions tab > **Traffic signs**.

Tips

If another tab or another function is selected in the instrument cluster, the traffic light information will appear in the status bar on the instrument cluster.

Messages

Applies to: vehicles with traffic light information

The following messages may appear depending on the vehicle equipment:

Malfunction! See owner's manual

The system could not be configured, for example due to a network malfunction. Switch the ignition off and shut down the vehicle to restart the system. Wait several minutes until the vehicle has shut down completely and then switch the ignition back on.

Function currently unavailable. See owner's manual

There is a temporary system malfunction. Check if one or more of the following situations applies and correct the issue if necessary:

Driver assistance

Cruise control system

Description

Applies to: vehicles with cruise control system

The **cruise control system** assists you in maintaining a constant speed above approximately 15 mph (20 km/h). The system maintains the desired speed by braking and accelerating.

WARNING

- Observe the safety precautions and note the limits of the assist systems, sensors, and cameras ⇨ *page 129* to ⇨ *page 132*.
- The cruise control system is only an assist system, and the driver is still responsible for operating the vehicle. The driver is especially responsible for braking, controlling the speed, and maintaining the distance to other vehicles.
- Switch the cruise control off temporarily when driving in turning lanes, highway exits, or in construction zones. This prevents the vehicle from accelerating to the stored speed when in these situations.

Note

Before driving downhill a long distance on a steep hill, decrease your speed and use the braking effect of recuperation ⇨ *page 93*. This reduces the load on the brakes.

Display overview

Applies to: vehicles with cruise control system

Indicator lights and messages in the speedometer inform you about the driving situation and the settings. The displays depend on the country and equipment.

Indicator lights

CRUISE /  - the cruise control system is switched on and actively controls the set speed.

An additional indicator will appear in the head-up display*.

WARNING

Observe the safety precautions and note the limits of the assist systems, sensors, and cameras ⇨ *page 129* to ⇨ *page 132*.

Switching the system on

Applies to: vehicles with cruise control system



Fig. 100 Operating lever: switching the system on

Requirement: the ignition must be switched on.

- ▶ To switch the system on, pull the lever toward you to position ①.

WARNING

- Observe the safety precautions and note the limits of the assist systems, sensors, and cameras ⇨ *page 129* to ⇨ *page 132*.
- If the brakes are malfunctioning (for example, overheating) while the cruise control system is switched on, the regulating functions may shut off automatically.

Preselecting or activating a cruise control speed

Applies to: vehicles with cruise control system

When the vehicle is stationary, you can preselect the speed to be maintained, or you can select the speed while driving.

Requirement: the system must be switched on.

- ▶ To preselect a cruise control speed when the vehicle is stationary, tap the lever toward \oplus/\ominus ⇨ *page 138*, *fig. 100*.
- ▶ To activate the cruise control speed, pull the lever toward position ② while driving.

- ▶ To set the current driving speed as the cruise control speed, press the button **1** on the lever.

Changing the cruise control speed

Applies to: vehicles with cruise control system

Requirement: the system must be switched on.

- ▶ To increase or decrease the cruise control speed in increments, tap the lever toward **+**/**-** ⇒ *page 138, fig. 100.*
- ▶ To increase or decrease the cruise control speed continuously, press and hold the lever toward **+**/**-**.

Overriding or deactivating the cruise control speed

Applies to: vehicles with cruise control system

You can override or deactivate the cruise control system. When you deactivate the system, your cruise control speed will be stored and you can resume that speed.

Requirement: the system must be switched on and the regulated speed must be activated.

Overriding

- ▶ To temporarily override the cruise control speed, press the accelerator pedal.
- ▶ To resume the stored regulated speed, remove your foot from the accelerator pedal.

If you override the cruise control system for a long period of time, the cruise control system will be deactivated.

Deactivating

- ▶ To deactivate the cruise control speed, press the lever to position **3** (not locked into place) ⇒ *page 138, fig. 100, or*
- ▶ Press the brake pedal.

WARNING

Resting your foot on the accelerator pedal could override the cruise control. Braking interventions and corrective actions by the system may not occur.

Switching the system off

Applies to: vehicles with cruise control system

If you do not want to use the cruise control system for a longer period of time, you can switch it off.

- ▶ To switch the system off, press the lever toward **3** (locked into place) ⇒ *page 138, fig. 100.*

The indicator light will turn off and the set speed will be cleared.

Messages

Applies to: vehicles with cruise control system

If **CRUISE** or  is displayed when there is a malfunction, the cruise control system functions may be unavailable or limited.

A message that indicates the cause and possible solution may appear with some displays. The weather conditions may be too poor or a sensor may be covered. Clean the area in front of the sensors ⇒ *page 132* and try to turn the system on again later.

If the malfunction remains, drive to an authorized Audi dealer or authorized Audi Service Facility immediately to have the malfunction corrected.

Efficiency assist

Description

Applies to: vehicles with efficiency assist

Efficiency assist can assist with predictive information in order to reduce fuel consumption. Depending on vehicle equipment, the system may access data from the navigation system, the camera behind the windshield, and the radar sensors.

If you have switched on automatic recuperation in the MMI and you remove your foot from the accelerator pedal, Efficiency assist will regulate the recuperation and coasting phases based on the situation.

Adjusting the efficiency assist

You can adjust efficiency assist functions individually. The settings depend on the vehicle equipment. ▶





- **Recuperation** ⇨ *page 93*.
- **Predictive messages** ⇨ *page 140*.
- **Predictive control** ⇨ *page 150*.

Situation symbols

Depending on the equipment version, efficiency assist can use the following symbols to indicate the situation to which the system is responding.

Depending on the equipment version, some of the symbols can only be displayed in the **Driver assistance** display to clarify to which situation the system is responding.

Some symbols only appear if **Predictive messages** are switched on, and some symbols only appear if **Predictive control** is switched on and adaptive cruise assist* is active.

Symbol	Description
	Slow down (predictive messages only)
	Speed limit (example)
	Exit ahead
	Intersection ahead
	Traffic circle ahead
	(predictive control only) If the indicator light turns on in green and red, it is indicating that there is a difference between the speed limit and the set speed.

WARNING

- Observe the safety precautions and note the limits of the assist systems, sensors, and cameras ⇨ *page 129* to ⇨ *page 132*.
- In certain situations, the recuperation may brake proactively. However, the recuperation braking effect is limited. Always be ready to brake to reduce the risk of an accident.

Tips

- The functions depend on the navigation data* being up-to-date and correct identification by the traffic sign recognition*.
- The system only detects traffic signs that specify a speed limit.
- The display in the instrument cluster is based on the units of measurement used for speed in the country where the vehicle is being operated. As a result, a display of 50 in the instrument cluster can mean either mph or km/h, depending on the country.
- Except for the road network, which is recorded in the navigation system's map information, certain functions may not be available.

Predictive messages

Applies to: vehicles with efficiency assist

The  symbol appears in the instrument cluster display when the efficiency assist recommends removing your foot from the accelerator pedal. Symbols indicate the situation to which the system is responding ⇨ *page 140*, *Situation symbols*.

Requirements

- The cruise control system* or the adaptive cruise assist* controls must not be active.
- The vehicle speed must be at least 20 mph (30 km/h).
- The remaining distance until the situation is reached must be large enough to allow the system to react to the situation.
- The Audi drive select **dynamic** mode is not selected.

Switching predictive messages on or off

You can switch predictive messages on or off. The possible settings depend on the vehicle equipment.

Applies to MMI: Select on the home screen: **VEHICLE** > **Efficiency assist** > **Predictive messages**. ▶

! WARNING

- Observe the safety precautions and note the limits of the assist systems, sensors, and cameras ⇒ *page 129* to ⇒ *page 132*.
- Pay attention to traffic and the area around your vehicle when efficiency assist is switched on. The driver is always responsible for assessing the traffic situation.

i Tips

- The traffic signs on the road always take priority over the display. The driver is always responsible for adhering to the regulations applicable in the country where the vehicle is being operated.
- When a route is planned using the navigation system*, then system displays messages based on an assumed route. Without route guidance, the system displays messages based on an assumed route.
- The wording of the message may vary depending on the Audi drive select* mode and the selector lever position that are selected.
- Additional messages are displayed when in the Audi drive select **efficiency*** mode.

Adaptive cruise assist

General information

Applies to: vehicles with adaptive cruise assist

Depending on the vehicle equipment, the adaptive cruise assist may consist of the following functions:

Within the limits of the system, the **adaptive speed assist** assists you while driving in controlling the speed and the set distance to the vehicle driving ahead. If the system detects a vehicle driving ahead, the adaptive speed assist can brake and accelerate your vehicle within the limits of the system. On open roads with no traffic, it functions like a cruise control system. The stored speed is maintained. When approaching a vehicle driving ahead, the adaptive speed assist automatically brakes to match that vehicle's speed and then maintains the set distance as much as possible. Once the system does not detect a vehi-

cle driving ahead, adaptive speed assist will accelerate up to the set speed.

Within the limits of the system, **Lane guidance** provides corrective steering to assist the driver with keeping the vehicle in the center of the lane as much as possible. You can adjust if the adaptive cruise assist will provide support with lane guidance ⇒ *page 145*, *Switching lane guidance on and off*.

In **stop-and-go traffic and in traffic jams**, the vehicle may brake to a full stop and then may also start driving again automatically under certain conditions.

Applies to: vehicles with predictive control: **predictive control** can adjust the speed based on traffic and road conditions ⇒ *page 146*.

! WARNING

Observe the safety precautions and note the limits of the assist systems, sensors, and cameras ⇒ *page 129* to ⇒ *page 132*.

i Tips

The system complies with United States FCC regulations and ISED regulations ⇒ *page 291*.

Limitations

Applies to: vehicles with adaptive cruise assist

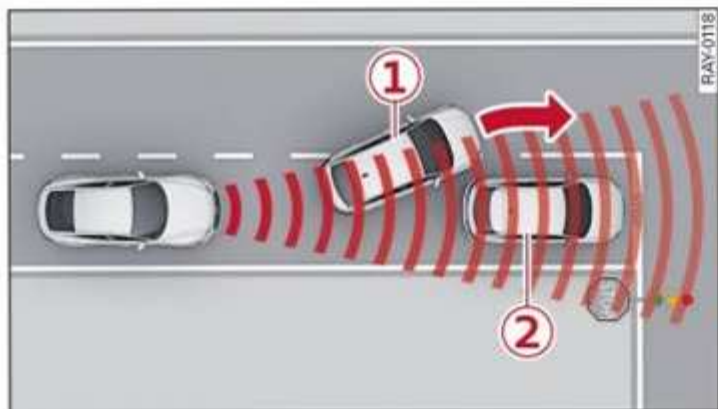

Fig. 101 Example: vehicle changing lanes and stationary vehicle

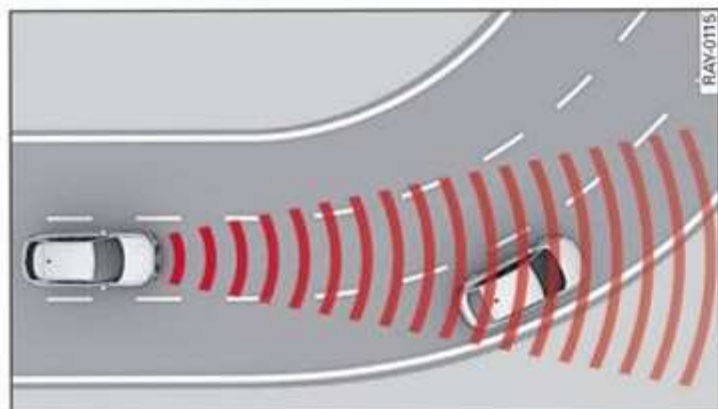

Fig. 102 Example: driving into a curve

In some situations, the adaptive cruise assist function is limited and you must assume control of the vehicle when necessary, for example by applying the brakes.

- If a vehicle that is already detected ① turns or changes lanes, the system cannot react to the vehicle ahead of it ② in all cases.
- When driving into a curve ⇒ *fig. 102* and out of a curve, the system may react to a vehicle in the neighboring lane and apply the brakes. You can override the system by pressing the accelerator pedal briefly.
- The system works with the various sensors and cameras in the vehicle. Vehicles can only be detected once they are within the area and range covered by the sensors ⇒ *page 130, fig. 92*.
- When driving around tight curves, a vehicle driving ahead that was previously detected may no longer be detected, and the system may accelerate unexpectedly.
- The system does not react to a stationary vehicle in the same lane if it expects that you can

easily drive around the stationary vehicle by turning the steering wheel.

- The system cannot react to stationary objects, such as vehicles at the end of a traffic jam, especially when traveling at high speeds.
- The system has a limited ability to detect vehicles that are a short distance ahead, off to the side of your vehicle, or moving into your lane.
- Objects that are difficult to detect, such as motorcycles, vehicles with high ground clearance, or vehicles with an overhanging load, may be detected late or not detected at all.
- The system does not respond to people, animals, or objects that are crossing or approaching from the opposite direction.

⚠ WARNING

Observe the safety precautions and note the limits of the assist systems, sensors, and cameras ⇒ *page 129* to ⇒ *page 132*.

Display overview

Applies to: vehicles with adaptive cruise assist



Fig. 103 Instrument cluster: display in speedometer

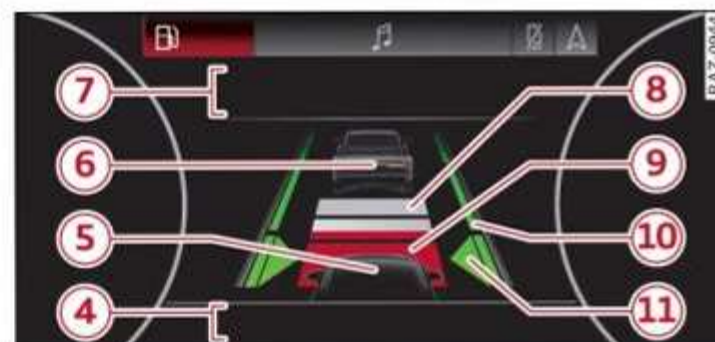

Fig. 104 Instrument cluster: driver assistance display

The driving situation and the settings are displayed in the instrument cluster ⇒ *fig. 103*. In the **Driver assistance** ⇒ *fig. 104* display, you can ▶

find more detailed information about the system. The displays depend on the country and equipment.

Display in the speedometer

The display in the speedometer is not available in all layouts*.

- ① Marking for the set speed
- ② Current vehicle speed
- ③ Available speed range for adaptive cruise assist (example)

Image in the Driver assistance display

The image in the **Driver assistance** display only appears if it was opened in the trip computer ⇒ *page 16*.

- ④ Messages and settings
- ⑤ Your vehicle
- ⑥ Detected vehicle driving ahead
- ⑦ Messages and settings
- ⑧ Set target distance
- ⑨ If you fall below the set distance, the distance bars turn red from the bottom upward.
- ⑩ Lane departure warning availability
- ⑪ Availability of lane guidance for adaptive cruise assist

Indicator lights

 – The speed/distance control is active. No vehicles were detected ahead. The stored speed is maintained.

 – The speed/distance control is active. A vehicle was detected ahead. The system controls the speed and distance from the vehicle driving ahead, and accelerates and brakes automatically.

 – The speed/distance control is active but the vehicle is not **ready to drive**. A vehicle was detected ahead. Your vehicle is stationary and will not start driving automatically.

 – The speed/distance control is active but the vehicle is not **ready to drive**. No vehicles were detected ahead. Your vehicle is stationary and will not start driving automatically.



 – Take over. The braking power is not sufficient ⇒ *page 145, Brake intervention request* or

the safe start monitor is providing a warning ⇒ *page 149*.

 – Lane guidance is active.

 – Take over steering. The system limits have been reached ⇒ *page 146, Steering intervention requests*.

 – Lane guidance is switched on but it is not active ⇒ *page 145, Lane guidance limitations*.

  – Take over steering. No steering detected or a system limit has been reached ⇒ *page 146, Steering intervention requests*.

WARNING

Observe the safety precautions and note the limits of the assist systems, sensors, and cameras ⇒ *page 129* to ⇒ *page 132*.

Using adaptive cruise assist

Applies to: vehicles with adaptive cruise assist



Fig. 105 Lever: using adaptive cruise assist



Fig. 106 Operating lever: changing the speed

Switching on

- To switch on the adaptive cruise assist, pull the lever up to position ① until it engages. ►

Storing the speed and activating regulation

If you have switched the system on, you can set the current speed as the “regulated speed” and activate regulation:

- ▶ Press the **SET** button **2**. The set speed is indicated with a marking in the speedometer **1** ⇒ *page 142, fig. 103* and shown in the instrument cluster ⇒ .
- ▶ To save the speed while the vehicle is stationary, also hold the brake pedal down.

You can set any speed between 15 mph (20 km/h) and the maximum possible speed range **3**¹⁾ ⇒ *page 142, fig. 103*.

Pausing cruise control

The control can be stopped at any time:

- ▶ While driving or when the vehicle is stationary: Press the lever away from you in the direction of the arrow, or
- ▶ While driving: Press the brake pedal.

The  indicator light turns off.

Resuming regulation

The previously set speed can be resumed at any time after a pause.

- ▶ To resume cruise control while driving, pull the lever toward you in the direction of the arrow.
- ▶ To resume cruise control when stationary, pull the lever toward you in the direction of the arrow while pressing the brake pedal.

Changing the speed

- ▶ To increase or decrease the set speed in increments, tap the lever in the **+**/**-** direction.
- ▶ To increase or decrease the set speed continuously, hold the lever toward **+** or **-** until the marking in the speedometer **1** ⇒ *page 142, fig. 103* has reached the desired speed.

Applies to: vehicles with predictive control: Predictive control can automatically adjust the set speed based on traffic and road conditions ⇒ *page 146*.

Preselecting a speed

You can also preselect the speed when adaptive cruise assist is not active by moving the lever in the desired direction **+**/**-**. Activate the previously selected speed by pulling the lever toward you in the direction of the arrow.

Switching off

If you do not want to use the adaptive cruise assist for a longer period of time, you can switch it off.

- ▶ Push the lever away from you into position **0** until it clicks into place.

The indicator light and the set speed will turn off.

WARNING

- Observe the safety precautions and note the limits of the assist systems, sensors, and cameras ⇒ *page 129* to ⇒ *page 132*.
- The adaptive cruise assist is only an assist system, and the driver is still responsible for vehicle operation. The driver is especially responsible for braking, steering, starting to drive, and controlling the speed and the distance from other vehicles.
- Turn on the adaptive cruise assist only if the surrounding conditions permit it. Always adapt your driving style to the current visual, weather, road, and traffic conditions.
- Switch the adaptive cruise assist off temporarily when driving in turning lanes, highway exits, or construction zones. This prevents the vehicle from accelerating to the stored speed when in these situations.
- If you press the **SET** button **2** when driving at speeds below 15 mph (20 km/h), the minimum possible speed that the system can maintain will be set. If no vehicle is detected ahead of you, the vehicle will accelerate up to that speed.

Tips

- Always keep your hands on the steering wheel so you can be ready to steer at any

¹⁾ Depending on the country and drive system

time. The driver is always responsible for adhering to the regulations applicable in the country where the vehicle is being operated.

- If you switch the ignition or the adaptive cruise assist off, the stored speed is erased for safety reasons.
- When the adaptive cruise assist is switched on, the ESC and the ASR are switched on automatically.
- The system cannot be switched off or it may be interrupted if the road exceeds the maximum possible grade for safe operation.

Switching lane guidance on and off

Applies to: vehicles with adaptive cruise assist and lane guidance

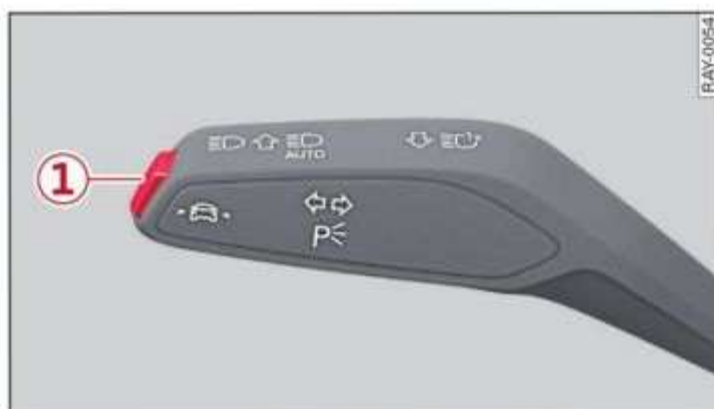

Fig. 107 Turn signal lever: lane guidance button

Within the limits of the system, lane guidance provides corrective steering to assist you with keeping the vehicle in the center of the lane as much as possible. This feature can be deactivated.

Switching lane guidance on and off

- ▶ To switch the availability of the lane guidance on or off, briefly press the button ① on the turn signal lever.

The availability of lane guidance is indicated with arrows ⑪ ⇒ page 142, fig. 104 and with indicator lights ⇒ page 143 in the **Driver assistance** display.

The system can assist you by providing corrective steering only when adaptive cruise assist is actively regulating and availability is switched on.

Lane guidance limitations

If  turns white, lane guidance is switched on but is not active. This may occur due to the following system limits or situations:

- The necessary lane marker lines have not been detected (for example, in a construction zone or because the lines are obstructed by snow, dirt, water, or lighting)
- The lane is too narrow or too wide
- The curve is too narrow
- Visibility is obstructed by a rise or dip.
- The turn signal was activated.
- The driver's hands are not on the steering wheel

WARNING

Observe the safety precautions and note the limits of the assist systems, sensors, and cameras ⇒ page 129 to ⇒ page 132.

Tips

- Always keep your hands on the steering wheel so you can be ready to steer at any time. The driver is always responsible for adhering to the regulations applicable in the country where the vehicle is being operated.
- Audi recommends only switching on lane guidance on well-constructed roads.



Driver intervention requests

Applies to: vehicles with adaptive cruise assist



Fig. 108 Instrument cluster: brake intervention request

Brake intervention request



If the  indicator light turns on and the message **Distance!** appears, press the brake pedal to apply the brakes ⇒ .

The braking effect by the adaptive cruise assist is not strong enough to maintain a sufficient distance to the vehicle driving ahead in this situation.

The display ① also appears if you have opened the **Driver assistance** display in the trip computer ⇒ *page 16*.

Steering intervention requests

If the  indicator light turns on, take over steering. The limits of the system have been reached, for example because the system's steering power is not sufficient in curves that are too narrow. The system will become inactive after a short time and will only become available again later.

If the  or  indicator lights turn on and a corresponding message appears, take over steering. Sufficient steering activity was not detected or a system limit has been reached. Keep your hands on the steering wheel so you can be ready to steer at any time. If you do not take over steering, adaptive cruise assist will be canceled. If the vehicle is equipped with emergency assist and it is ready to function, it will be activated ⇒ *page 159*.

WARNING

- Observe the safety precautions and note the limits of the assist systems, sensors, and cameras ⇒ *page 129* to ⇒ *page 132*.
- The adaptive cruise assist is only an assist system, and the driver is still responsible for vehicle operation. The driver is especially responsible for braking, steering, and maintaining the distance to other vehicles.

Tips

- Always keep your hands on the steering wheel so you can be ready to steer at any time. The driver is always responsible for adhering to the regulations applicable in the country where the vehicle is being operated.
- The intervention requests may be accompanied by additional audio or visual signals, depending on the situation.

Predictive control

Applies to: vehicles with adaptive cruise assist and predictive control

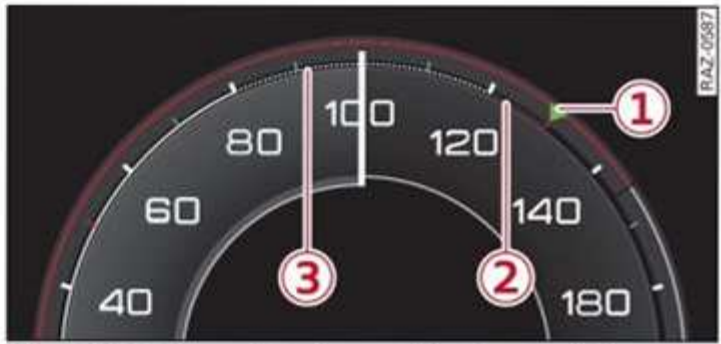

Fig. 109 Instrument cluster: speedometer: predictive control display

General information

With predictive control, efficiency assist adapts the set speed in adaptive cruise control ① based on detected speed limits and the upcoming route. Once the system no longer detects any incidents, adaptive cruise control will accelerate again to the last speed that you set. After switching on the ignition, the availability of predictive control is indicated by a message when the adaptive cruise assist is first activated.

Incident symbols indicate the situation to which predictive control is reacting ⇒ *page 140*, *Situation symbols*.

Requirements

- The predictive control is turned on in the **Driver assistance** menu under **Adaptive cruise assist** ⇒ *page 132*.
- The adaptive cruise assist must be actively regulating ⇒ *page 143*.
- The system can only react to speed limits that are 15 mph (20 km/h) or higher.
- The map content of the navigation system* must be updated regularly in order for the system to work without restrictions ⇒ *page 201*.

Display in the speedometer

The display depends on vehicle equipment and is not available in all layouts*.

- ① The marking shows the set speed (regulated speed that was set by you or by the predictive control).
- ② The red band shows the difference between the speed limit and the set speed that is set. ▶

- ③ The marked band shows if the vehicle speed is planned to drop below the set speed due to the road layout.

Overriding control

You can override the predictive control at any time by pressing the accelerator pedal. If the system changes the vehicle speed to adapt to speed limits, you can change the speed using the lever ⇒ *page 143, fig. 106*.

Messages

If a message with **Predictive control** is displayed when there is a malfunction, the functions are unavailable or limited.

A message that indicates the cause and possible solution may appear with some displays. The weather conditions may be too poor or a sensor may be covered. Clean the area in front of the sensors ⇒ *page 132* and try to turn on the systems again later.

If the malfunction remains, drive to an authorized Audi dealer or authorized Audi Service Facility immediately to have the malfunction corrected.



WARNING

- Observe the safety precautions and note the limits of the assist systems, sensors, and cameras ⇒ *page 129* to ⇒ *page 132*.
- Pay attention to traffic and the area around your vehicle when predictive control is switched on. The driver is always responsible for assessing the traffic situation.
- The system does not consider “right of way” rules and does not respond to traffic lights, so lack of driver attention in these situations can increase the risk of an accident.
- The speed when driving through curves may be different from what you as a driver would do or may not be suitable for the weather and road conditions. If necessary, apply the brakes and reduce the selected speed to be maintained in the **Adjustment to curves**

along route setting to reduce the risk of an accident.

Tips

- Predictive control can exceed or drop below the maximum permitted speed. The driver is always responsible for adhering to the permitted speed limits.
- The traffic signs on the road always take priority over the display. The driver is always responsible for adhering to the regulations applicable in the country where the vehicle is being operated.
- If a speed limit is detected, the marking ① ⇒ *page 142* of the set speed limit will be adjusted even if the adaptive cruise assist is not actively regulating.
- You may temporarily fall below or exceed the set speed due to recuperation.
- Control by the system depends on which adaptive cruise assist driving program is set or on the selected Audi drive select* mode.
- After switching on the ignition and first driving onto a freeway or similar road without a speed limit, the system will regulate the speed to 80 mph (130 km/h)¹⁾. Then the system adjusts to the last speed set by the driver.
- There is no adaptation to speed limits when driving through highway interchanges and when driving on or off the expressway.
- The system can fail to provide control or the control may be faulty if the values from the camera-based traffic sign recognition* are incorrect or the navigation system* map data is outdated.
- When route guidance is switched on, the system adapts to the route provided by the navigation system. Driving without route guidance or leaving a route can result in faulty control.

¹⁾ In certain countries.

Setting the distance

Applies to: vehicles with adaptive cruise assist



Fig. 110 Operating lever: setting the distance

When approaching a vehicle driving ahead, the adaptive cruise assist brakes to the set speed and then maintains the set distance. If the vehicle driving ahead accelerates, then the adaptive cruise assist will also accelerate up to the speed that you have set.

- ▶ Tap the rocker switch to display the distance that is currently set.
- ▶ To increase or decrease the distance in increments, tap the switch again toward ⊕ or ⊖.

The newly-set distance will be shown briefly, for example with the indicator light.

If you adjust the speed, you must also change the time gap to the vehicle driving ahead. The higher the speed, the greater the distance that is needed. The following distances can be set:

Sym- bol	Time distance	Distance at 62 mph (100 km/h)
	Approximately 1 second	92 feet (28 m)
	Approximately 1.3 seconds	118 feet (36 m)
	Approximately 1.8 seconds (the set- ting corresponds to a distance that is "half of the vehicle speed")	164 feet (50 m)

Sym- bol	Time distance	Distance at 62 mph (100 km/h)
	Approximately 2.4 seconds	219 feet (67 m)
	Approximately 3.6 seconds	328 feet (100 m)

! WARNING

Observe the safety precautions and note the limits of the assist systems, sensors, and cameras ⇒ page 129 to ⇒ page 132.

i Tips

- When setting the distance, the driver is responsible for adhering to any applicable legal regulations.
- In the **Driver assistance** display, a graphic display is shown instead of the indicator lights ⇒ page 142, fig. 104. The display matches the functions of the indicator lights.
- Depending on the selected driving program and distance, driving behavior when accelerating may vary from moderate to sporty ⇒ page 150, *Adjusting the adaptive cruise assist*.
- The distances provided are specified values. Depending on the driving situation and how the vehicle ahead is driving, the actual distance may be more or less than these target distances.

Additional functions

Applies to: vehicles with adaptive cruise assist



Fig. 111 Lever: using adaptive cruise assist

Requirement: all additional functions require adaptive cruise assist control to be active.

Overriding control

You can override control by the system completely, for example if you would like to pass another vehicle or if you would like to accelerate faster.

- ▶ To accelerate manually, pull the lever toward you in the direction of the arrow and hold it there, or press the accelerator pedal.
- ▶ To resume the usual cruise control, release the lever or remove your foot from the accelerator pedal.

When you are in the **Driver assistance** display, the message **Overridden** will appear.

WARNING

- Observe the safety precautions and note the limits of the assist systems, sensors, and cameras ⇒ *page 129* to ⇒ *page 132*.
- Resting your foot on the accelerator pedal could override the cruise control. Braking interventions and corrective actions by the system may not occur.
- The functions only provide assistance. The driver is still responsible for controlling the vehicle when using these functions. The driver is especially responsible for changing lanes, applying the brakes, controlling the speed, and maintaining the distance to other vehicles.

Driving in stop-and-go traffic

Applies to: vehicles with adaptive cruise assist





Applies to: vehicles with safe start monitor
Fig. 112 Instrument cluster: safe start monitor

Stopping with adaptive cruise assist

The adaptive cruise assist also assists you in stop-and-go traffic. Within the limits of the system, your vehicle may brake and remain at a stop if a vehicle driving ahead stops.

Starting to drive with adaptive cruise assist¹⁾



As long as the message  **ready to drive** and  is displayed, your vehicle will begin driving when the vehicle ahead starts to move ⇒ .

If your vehicle is stopped for too long, it will no longer drive autonomously for safety reasons, and the message will turn off.

- ▶ To extend  **ready to drive** for a brief time or reactivate it, pull the lever toward you briefly in the direction of the arrow ⇒ *page 148*, *fig. 111*.
- ▶ To resume manual control of the vehicle, tap the accelerator pedal.

Safe start monitor

Applies to: vehicles with safe start monitor

The vehicle can still start to drive even if certain obstacles are detected when starting to drive ⇒ . If the surrounding area detection detects an obstacle, you will be alerted to the danger by the  indicator light.

If you are in the **Driver assistance** display, the display  ⇒ *fig. 112* and the message **Warning!** will also appear. An audio signal will sound as well. Your vehicle will drive more slowly when starting. This may also occur in some situations when there is no apparent obstacle.

- ▶ Press the brake pedal to slow your vehicle if necessary.

WARNING

- Observe the safety precautions and note the limits of the assist systems, sensors, and cameras ⇒ *page 129* to ⇒ *page 132*.
- If the message  **ready to drive**¹⁾ appears, your vehicle will start driving even if there is an obstacle between your vehicle and the vehicle ahead. To reduce the risk of an accident, always make sure there are no

¹⁾ This is not available in some countries.

obstacles between your vehicle and the vehicle driving ahead.

Tips

For safety reasons, adaptive cruise assist only starts driving actively if:

- The driver's safety belt is fastened,
- All doors and the hood are closed
- The vehicle has not been stationary for a long period of time

Adjusting the adaptive cruise assist

Applies to: vehicles with adaptive cruise assist

You can adjust the adaptive cruise assist to your preferences in the **Driver assistance** menu ⇒ *page 132*. The settings depend on the vehicle equipment.

Possible settings:

Store last distance - The last distance that was set will be stored after the ignition is switched off. If the distance is not stored, distance  (time distance of approximately 1.8 seconds) is automatically preset every time the ignition is switched on.

Applies to: vehicles without Audi drive select

Driving program - Depending on the selected driving program and distance, the vehicle handling will be adjusted from **Sport** to **Comfort**.

Applies to: vehicles with Audi drive select

Vehicle handling will be adjusted based on the set distance and the selected Audi drive select mode ⇒ *page 100*.



Predictive control > Set speed limit - adaptation to speed limits can be switched **On** or **Off**. Regulation **With tolerance** can also be selected, if desired. In this scenario, you may fall below or exceed the set speed in favor of increased efficiency.

Predictive control > Adjustment to curves along route - regulation based on the road ahead can be switched **Off** or set from **Slow** to **Fast** based on your preference. The setting influences vehicle

handling with predictive control, for example the speed for driving through curves.

Messages

Applies to: vehicles with adaptive cruise assist

If  or  is displayed when there is a malfunction, the adaptive cruise assist functions may be unavailable or limited.

A message that indicates the cause and possible solution may appear with some displays. The weather conditions may be too poor or a sensor may be covered. Clean the area in front of the sensors ⇒ *page 132* and try to turn on the systems again later.

If the malfunction remains, drive to an authorized Audi dealer or authorized Audi Service Facility immediately to have the malfunction corrected.

The following messages may appear depending on the vehicle equipment:

Adaptive cruise assist: please take over!

This message appears if the vehicle rolls back when starting on a slight incline, even though the systems are active. Press the brake pedal to prevent the vehicle from rolling or starting to move.

Distance warning

Description

Applies to: vehicles with distance warning

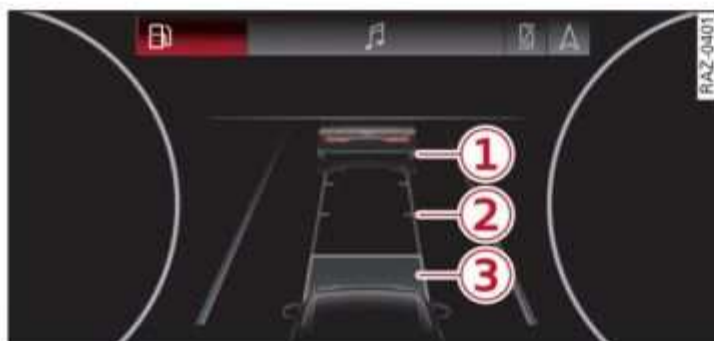

Fig. 113 Instrument cluster: display of current distance



Fig. 114 Instrument cluster: distance warning

General information

At speeds above approximately 40 mph (65 km/h), this function measures the distance to the vehicle ahead as time. If the distance falls below the warning threshold and remains there, the system will warn you of the hazard with the  indicator light.

Image in the Driver assistance display

The display only appears if the **Driver assistance** display is selected in the trip computer \Rightarrow page 16 and the adaptive cruise assist* is not actively controlling the vehicle.

- ① Detected vehicle driving ahead
- ② Use the markings to help you estimate the distance to an obstacle. Each marking represents approximately one second.
- ③ Set warning threshold. Depending on the settings, the display will be colored in from the bottom to the top.
- ④ The actual distance is smaller than the set distance and you will be informed about the danger.



Adjusting the distance warning

You can turn the distance warning on or off in the **Driver assistance** menu, or adjust it to your preferences \Rightarrow page 132. The settings depend on the vehicle equipment.

Possible settings:

- **Warning threshold**

Messages

If  or  is displayed when there is a malfunction, the distance warning functions may be unavailable or may be limited.

A message that indicates the cause and possible solution may appear with some displays. The weather conditions may be too poor or a sensor may be covered. Clean the area in front of the sensors \Rightarrow page 132 and try to turn the system on again later.

If the malfunction remains, drive to an authorized Audi dealer or authorized Audi Service Facility immediately to have the malfunction corrected.

WARNING

Observe the safety precautions and note the limits of the assist systems, sensors, and cameras \Rightarrow page 129 to \Rightarrow page 132.

Tips

- The driver is always responsible for adhering to the regulations applicable in the country where the vehicle is being operated.
- You may fall below the warning threshold briefly when passing or when quickly approaching a vehicle driving ahead. There is no warning in this scenario. A warning is given only if you fall below the warning threshold for an extended period of time.

Lane departure warning

General information

Applies to: vehicles with lane departure warning

The lane departure warning can detect lane marker lines within the limits of the system. If 

you are approaching a detected lane marker and it appears likely that you will leave the lane, the system can warn you with corrective steering and a steering wheel vibration, if necessary.

The system functions in the speed range of approximately 40 mph - 155 mph (65 km/h - 250 km/h).

⚠ WARNING

Observe the safety precautions and note the limits of the assist systems, sensors, and cameras ⇒ *page 129* to ⇒ *page 132*.

Description

Applies to: vehicles with lane departure warning



Fig. 115 Turn signal lever: button for lane departure warning and lane guidance for adaptive cruise assist*



Fig. 116 Instrument cluster: driver assistance display

Switching the lane departure warning on and off

- ▶ You can turn the lane departure warning on or off in the **Driver assistance** menu ⇒ *page 132*, or
- ▶ Press and hold the button ① on the turn signal lever until the indicator light in the instrument cluster turns off or on.

Display and warning

The availability, readiness to provide warnings, and the warnings are indicated with indicator lights. The lane departure warning is ready to provide warnings if an object is detected on at least one side of the individual lane.

Driver assistance display	Indicator lights	Meaning
② White line(s)	on the corresponding side	the lane departure warning is switched on but not ready to provide warnings.
③ Green line(s)	on the corresponding side	The lane departure warning is switched on and ready to provide warnings.
④ Red line	on the corresponding side	The lane departure warning system will warn you with a corrective steering intervention before exiting the lane.
-	on both sides	Lane guidance by the emergency assist* is active ⇒ <i>page 159</i> .

If the lane departure warning must intervene for a long period of time, a message will request you to drive in the center of the lane. The steering wheel can also vibrate to warn you if lane boundaries are detected during a passing maneuver. You can turn the steering wheel vibrations on or off in the **Driver assistance** menu ⇒ *page 132*. The settings depend on the vehicle equipment.

If the indicator light turns on, the lane departure warning is not ready to provide warnings. This may occur due to the following system limits or situations:

- The necessary lane marker lines have not been detected (for example, in a construction zone or because the lines are obstructed by snow, dirt, water, or lighting)
- The speed is below the activation speed
- The lane is too narrow or too wide

- The curve is too narrow
- Visibility is obstructed by a rise or dip.
- The driver's hands are not on the steering wheel
- The turn signal was activated.

Steering intervention request

If the lane departure warning intervenes multiple times when no steering activity is detected, the steering intervention request will provide a warning using audio and visual signals, such as . Take over the steering and keep your hands on the steering wheel so that you will be ready to steer at any time. The system may no longer be ready to provide warnings after a short time, and it will only become active again later.

If you do not take over steering, the lane departure warning will no longer be ready to provide warnings. If the vehicle is equipped with emergency assist and it is ready to function, it will be activated \Rightarrow page 159.

Behavior when a turn signal is active

Applies to: vehicles without side assist: The system will not warn you if you activate a turn signal before crossing the lane marker line. In this case, it assumes that you are changing lanes intentionally.

Applies to: vehicles with side assist: If the turn signal is activated, the lane departure warning is ready, and a lane change has been classified as critical by the lane departure warning due to vehicles traveling beside you or due to approaching vehicles, then a noticeable corrective steering movement will occur shortly before exiting the lane. This will attempt to keep your vehicle in the lane.

WARNING

- Observe the safety precautions and note the limits of the assist systems, sensors, and cameras \Rightarrow page 129 to \Rightarrow page 132.
- The system uses corrective steering to warn that the vehicle is leaving the lane. The driver is always responsible for keeping the vehicle in the driving lane.



- Corrective steering may not occur at all in certain situations, such as during heavy braking. Always be ready to intervene.

Tips

- Always keep your hands on the steering wheel so you can be ready to steer at any time. The driver is always responsible for adhering to the regulations applicable in the country where the vehicle is being operated.
- The system does not provide any corrective steering or steering wheel vibrations if it detects that you are passing another vehicle.
- The image in the **Driver assistance** display only appears if it was opened in the trip computer \Rightarrow page 16.

Messages

Applies to: vehicles with lane departure warning

If  or  is displayed when there is a malfunction, the lane departure warning and lane guidance functions of the adaptive cruise* functions may be unavailable or limited.

A message that indicates the cause and possible solution may appear with some displays. The weather conditions may be too poor or the camera may be covered. Clean the area in front of the camera \Rightarrow page 132 and try to turn on the systems again later.

If the malfunction remains, drive to an authorized Audi dealer or authorized Audi Service Facility immediately to have the malfunction corrected.

Audi pre sense

Function overview

Applies to: vehicles with Audi pre sense

Within the limits of the system, the Audi pre sense functions can initiate measures in certain driving situations to protect the vehicle occupants and other road users. Depending on the vehicle equipment, various Audi pre sense systems may be installed: 

- **Audi pre sense basic** can react during emergency and dangerous braking maneuvers and unstable driving situations (such as oversteering or understeering).
- **Audi pre sense front** can detect an impending frontal impact and react with warnings, braking interventions, and preemptive safety measures for the vehicle occupants.
- **Audi pre sense rear** monitors the rear traffic behind your vehicle and can react to an impending rear impact.

Audi pre sense safety measures

Applies to: vehicles with Audi pre sense

Depending on the vehicle speed and the vehicle equipment, the following functions may be initiated in certain situations:

- Visual and audio warnings
- Reversible tensioning of safety belts
- Closing the windows and panoramic glass roof
- Adjusting the seats
- Other preemptive safety measures by individual systems

WARNING

Observe the safety precautions and note the limits of the assist systems, sensors, and cameras ⇨ [page 129](#) to ⇨ [page 132](#).

Tips

- Depending on the risk situation that is detected and the selected Audi drive select* mode, not all preemptive safety measures may be initiated under certain circumstances. Certain functions can be adjusted or skipped if necessary.
- Audi pre sense may also be limited or unavailable under certain circumstances, for example if:
 - If there are persons in the vehicle who are not using a safety belt.
 - After turning on the ignition, as long as the  indicator light is on.
 - When driving in reverse.
 - There is an airbag control module malfunction

- System functions may not be available if the ESC is limited or switched off, or if there is a malfunction.

Audi pre sense basic

Applies to: vehicles with Audi pre sense basic

Audi pre sense basic is automatically active at speeds of approximately 20 mph (30 km/h) and higher. Audi pre sense basic can trigger preemptive safety measures during emergency braking and dangerous braking maneuvers as well as in unstable driving situations, such as oversteering or understeering ⇨ [page 154](#), *Audi pre sense safety measures*.

The message **Audi pre sense**  will warn you about the danger.

WARNING

Observe the safety precautions and note the limits of the assist systems, sensors, and cameras ⇨ [page 129](#) to ⇨ [page 132](#).

Audi pre sense front

Applies to: vehicles with Audi pre sense front

Within the limits of the system, Audi pre sense front can warn about an impending front end collision and brake the vehicle strongly, if necessary. The system uses the data from the front radar sensors as well as the camera behind the windshield, and is available at speeds above approximately 3 mph (5 km/h).

Driving situations

The situations to which the system reacts depends on the vehicle speed.

Up to speeds of approximately 50 mph (85 km/h), the system may react to the following situations:

- When approaching a stationary vehicle
- A pedestrian or cyclist is moving inside your lane

Up to speeds of approximately 155 mph (250 km/h), the system may react to the following situations:

- A vehicle driving ahead clearly applies the brakes
- When approaching a vehicle ahead that is clearly traveling more slowly
- Approaching a stopped vehicle, as long as the system has already detected that this vehicle is driving in the same direction as your vehicle

Prewarning

The system can provide warnings about detected dangers at speeds above approximately 20 mph (30 km/h). **Audi pre sense**  appears in the instrument cluster and an audio signal plays.

A brief application of the brakes

If a collision with vehicles is imminent, there may be an acute warning using a brief application of the brakes. You will also be warned about the danger by an indicator in the instrument cluster display. You may only be able to avoid a collision by swerving or braking strongly.

Automatic braking force increase

If there is an impending collision and you are not applying the brakes enough, the braking force may be increased, depending on the situation.

Automatic braking

If you do not react to the acute warning, the system may apply the brakes with strong braking force within the limits of the system in order to reduce the speed of impact in the event of a collision.

If the brakes were applied until the vehicle stopped,  **Please take over!** will appear in the instrument cluster and you must take over control of the vehicle.

WARNING

- Observe the safety precautions and note the limits of the assist systems, sensors, and cameras ⇨ *page 129* to ⇨ *page 132*.
- Audi pre sense cannot overcome natural physical laws. It is a system designed to assist and it cannot prevent a collision in every

circumstance. The driver must always intervene. The driver is always responsible for braking in a timely manner. Do not let the increased safety provided tempt you into taking risks. This could increase your risk of a collision.

- Among other things, Audi pre sense front does not react to pedestrians and cyclists who are crossing at an angle. It also does not react to groups of people, animals, crossing vehicles, or oncoming vehicles and objects, such as posts, guardrails, and rail vehicles.
- Audi pre sense may be limited or unavailable in curves or when it is dark.
- Loose objects can be thrown around the vehicle interior during sudden driving or braking maneuvers, which increases the risk of an accident. Store objects securely while driving.
- Make sure that each person in the vehicle has their safety belt fastened correctly and follows the instructions for proper seating ⇨ *page 60*.
- In trailer mode, the braking behavior of the vehicle and trailer may be different than usual during automatic braking.

Audi pre sense rear

Applies to: vehicles with Audi pre sense rear

Within the limits of the system, Audi pre sense rear uses data from radar sensors at the rear corners of the vehicle and calculates the probability of a rear-end collision with the vehicle behind you.

Audi pre sense preemptive safety measures can be initiated if the risk of a collision with the vehicle behind you is detected.

WARNING

- Observe the safety precautions and note the limits of the assist systems, sensors, and cameras ⇨ *page 129* to ⇨ *page 132*.
- Audi pre sense rear does not react to pedestrians, animals, crossing objects, and objects not detected as vehicles.

i Tips

- Audi pre sense rear functions switch off when trailer mode is detected. There is no guarantee the functions will switch off when using a retrofitted trailer hitch.
- Audi pre sense rear functions may also switch off if there is a malfunction in the side assist system.

Adjusting Audi pre sense

Applies to: vehicles with Audi pre sense

You can switch Audi pre sense and the associated systems on or off in the **Driver assistance** menu, or adjust them individually ⇨ *page 132*. The settings depend on the vehicle equipment.

Setting the prewarning

You can adjust the warning time for the prewarning to your preference (**Early/Medium/Late**) or switch the prewarning off.

Set the warning time for the early warning to **Early** at first. If you feel that the prewarnings appear too early, then set the warning time to **Medium**. The **Late** warning time should only be set in special circumstances.

i Tips

- If Audi pre sense is switched off, it will switch on again automatically once the ignition is switched on again.
- Switch Audi pre sense off when you are not using public streets, when loading the vehicle onto a vehicle carrier, train, ship, or other type of transportation, or when towing the vehicle. This can help to prevent an undesired intervention from the Audi pre sense system.

Messages

Applies to: vehicles with Audi pre sense

If  is displayed when there is a malfunction, the Audi pre sense functions may be unavailable or may be limited.

A message that indicates the cause and possible solution may appear with some displays. The

weather conditions may be too poor or a sensor may be covered. Bring the vehicle to a full stop, switch the ignition off, and clean the area in front of the sensors ⇨ *page 132*.

If the message still appears after switching the ignition on again, have an authorized repair facility correct the malfunction as soon as possible.

Side assist

Description

Applies to: vehicles with side assist

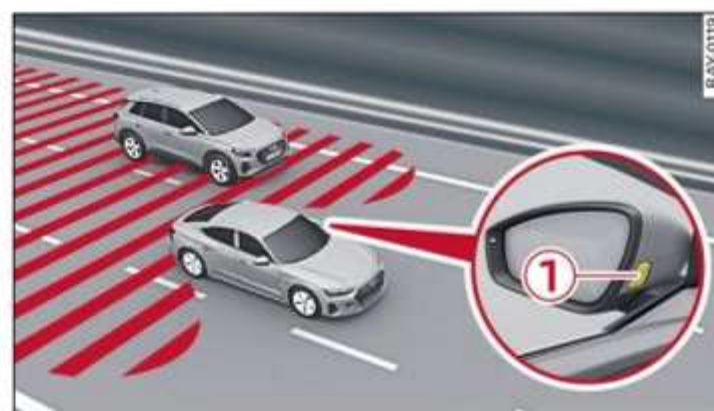

Fig. 117 Driving situations and displays in the exterior mirror

General information

Side assist monitors the blind spot and traffic behind your vehicle and provides assistance when you are changing lanes. If the system detects an object approaching and classifies it as critical, the display ① in the exterior mirror on that side of the vehicle will turn on.

Driving situations

The side assist warning is active at speeds above approximately 9 mph (15 km/h) and can help in situations such as the following:

- Your vehicle is being passed. The faster another vehicle approaches from behind, the sooner the display in the exterior mirror will turn on.
- There are vehicles traveling in the same direction as you in a lane adjacent to yours. The display in the exterior mirror will turn on when the detected object is in the “blind spot”, at the latest.
- You are slowly passing another vehicle. If the difference in speed between the two vehicles is ▶

less than 9 mph (15 km/h), the display in the exterior mirror will turn on.

Information stage

As long as you do not activate a turn signal, the system will inform you about objects classified as critical by turning on the display in the respective exterior mirror ①.

The display remains dim in the information stage so that you are not distracted while looking forward.

Warning stage

Once you activate a turn signal, the system will inform you about objects classified as critical by turning on the display in the respective exterior mirror.

If other driver assistance systems (depending on vehicle equipment) detect that your vehicle is about to leave the lane, the display will blink even if the turn signal lever is not activated to warn you about objects that are classified as critical. You can also be warned with corrective steering ⇒ *page 151, Lane departure warning*.

System limitations

The system uses the data from the radar sensors at the rear corners of the vehicle ⇒ *page 132, fig. 95*. They are designed to detect the left and right adjacent lanes when the road lanes are the normal width. In some situations, the system may react to vehicles in your own lane or lanes that are not directly adjacent to yours, or to objects on the side of the road. In this case, the display will turn on even though there is no vehicle in the critical area. These situations may include:

- Driving on the edge of your own lane
- Narrow lanes
- Curves
- High barriers on the side of the road



WARNING

- Observe the safety precautions and note the limits of the assist systems, sensors, and cameras ⇒ *page 129 to ⇒ page 132*.

- The display may not appear on time when vehicles are approaching or being passed very quickly.

Tips

- The radar sensors are calibrated once when driving the first few miles after delivery of the vehicle, as well as after repairs to the sensor system. During the calibration period, the sensor range may be limited.
- If the window glass in the driver's door or front passenger's door has been tinted, the display in the exterior mirror may be incorrect.
- The system is not available when towing a trailer. There is no guarantee the system will switch off when using a retrofitted trailer hitch. Do not use these functions when towing a trailer.
- The coverage areas of the sensors ⇒ *fig. 117* are diagrams and do not represent a true-to-scale image of the sensor ranges.
- The system complies with United States FCC regulations and ISED regulations ⇒ *page 291*.

Adjusting side assist

Applies to: vehicles with side assist

You can turn the side assist on or off in the **Driver assistance** menu, or adjust it to your preferences ⇒ *page 132*. The settings depend on the vehicle equipment.

Possible settings:

Brightness



Change the brightness only when side assist is switched on, so that the selected setting can be checked in the exterior mirror displays. Adjust the brightness to a level where the display in the information stage will not disrupt your view ahead. Because the display brightness automatically adapts to the ambient light, it may have already been adjusted to the highest or lowest setting during the automatic adaptation. ▶

i Tips

If the system is switched on, the displays on the exterior mirrors will turn on briefly each time the ignition is switched on.

Messages

Applies to: vehicles with side assist

If  or  is displayed when there is a malfunction, the side assist and exit warning system functions may be unavailable or may be limited.

A message that indicates the cause and possible solution may appear with some displays. The weather conditions may be too poor or a sensor may be covered. Clean the sensor area at the rear corners of the vehicle \Rightarrow page 132, fig. 95 and try to turn the systems on again later.

If the malfunction remains, drive to an authorized Audi dealer or authorized Audi Service Facility immediately to have the malfunction corrected.

Exit warning

Description

Applies to: vehicles with exit warning system

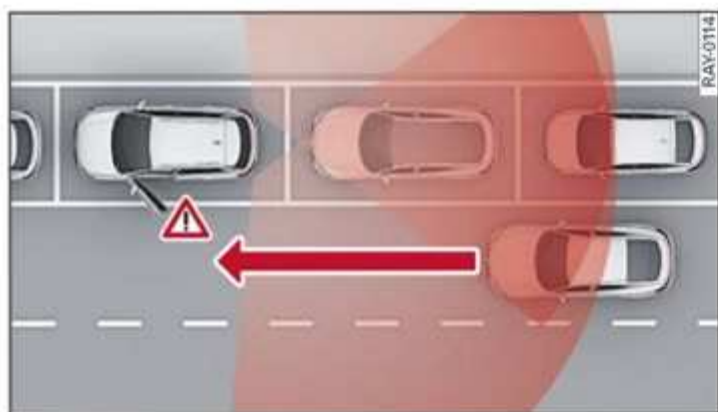

Fig. 118 Approaching traffic detected

General information

Within system limits, the exit warning system can detect traffic approaching from behind such as vehicles, and provide assistance based on this information when you are exiting the vehicle \Rightarrow fig. 118. The system uses the data from the radar sensors at the rear corners of the vehicle.

Displays and warnings

If a door is opened while the vehicle is stationary, the display in the exterior mirror on the same side of the vehicle $\textcircled{1} \Rightarrow$ page 156, fig. 117 will blink and an audible signal will sound if another road user is detected in a critical situation. If another road user that is classified as critical is approaching while a door is already open, the displays on that door will turn on.

The same messages apply for the exit warning system and side assist \Rightarrow page 158.

Switching the exit warning on and off

You can turn the exit warning on or off in the **Driver assistance** menu \Rightarrow page 132.

! WARNING

- Observe the safety precautions and note the limits of the assist systems, sensors, and cameras \Rightarrow page 129 to \Rightarrow page 132.
- Always pay attention to traffic and to the area around your vehicle. The exit warning system does not replace the attention of the vehicle occupants. The vehicle occupants are always responsible for opening the doors and exiting the vehicle.
- The exit warning system does not respond to people and cannot warn you about every type of approaching object, such as cyclists. Always monitor the traffic as well as the vehicle's surroundings with direct eye contact.
- The display may not appear in time when vehicles are approaching very quickly.
- The exit warning system does not react to stationary objects or pedestrians.
- The exit warning system will not provide alerts if your vehicle is pulled too far into the parking space so that it is hidden by adjacent vehicles.

i Tips

- The exit warning system can be available for up to approximately three minutes after unlocking the vehicle and opening the door as well as after switching off the ignition.
- The system is not available when towing a trailer. There is no guarantee the system

will switch off when using a retrofitted trailer hitch. Do not use these functions when towing a trailer.

- The display brightness for the exit warning system cannot be adjusted.
- The coverage areas of the sensors \Rightarrow *fig. 118* are diagrams and do not represent a true-to-scale image of the sensor ranges.
- The system complies with United States FCC regulations and ISED regulations \Rightarrow *page 291*.

Emergency assist

Description

Applies to: vehicles with emergency assist

General information

Within the limits of the system, emergency assist can detect inactivity from the driver. In these instances, the system will give a warning, assume control of the vehicle if necessary, and automatically bring the vehicle to a stop in the lane.

When switched on, emergency assist is automatically available when lane guidance for adaptive cruise assist is activated and the vehicle speed is approximately 6 mph (10 km/h) or greater. When adaptive cruise assist is not activated, emergency assist will only be available when switched on if the lane departure warning is ready to provide warnings and the speed is greater than approximately 40 mph (65 km/h).

If one of the requirements for adaptive cruise assist or the lane departure warning is no longer met, the system may only function with limitations or it may deactivate automatically.

Emergency assist functions

Measures may be initiated in stages. The vehicle can intervene within the limits of the system. The measures depend on the dangerous situation and the vehicle equipment:

- Visual and audio warnings
- Vehicle control
- Reduction of vehicle speed in stages

- Lowers the volume of the Infotainment system
- Tugs on the safety belt
- Activates the brakes
- The emergency flashers are activated ¹⁾
- Audi pre sense preemptive safety measures are triggered \Rightarrow *page 154*
- The brakes are applied until the vehicle is stationary
- The vehicle horn is activated repeatedly

As soon as the vehicle comes to a full stop, it prepares for the persons in the vehicle to be rescued. The parking brake is set, the doors are unlocked, and the interior lighting is activated. The emergency call¹⁾ will be started if necessary once the vehicle has been stationary for several seconds.

Display

If  is displayed for example, the emergency assist lane guidance is active.

Overriding the emergency assist

You can override emergency assist as follows



\Rightarrow :

- Move the steering wheel, or
- Press the brake pedal, or
- Press the accelerator pedal distinctly, or
- Switch emergency assist off in the MMI.





When stationary, you can end the emergency assist by shifting into any selector lever position or releasing the parking brake \Rightarrow *page 97*.

Switching the emergency assist on or off



You can turn the emergency assist off/on in the **Driver assistance** menu \Rightarrow *page 132*.

If you switch the system off, the  or  indicator light will turn on and a corresponding message will appear.

Messages

If , ,  or  is displayed when there is a malfunction, the rear emergency assist functions may be unavailable or may be limited. ▶

¹⁾ This function is not available in every market and on all vehicle equipment levels.

The  or  indicator light can also turn on if the system has been switched off manually in the **Driver assistance** menu.

A message that indicates the cause and possible solution may appear with some displays. The weather conditions may be too poor or a sensor may be covered. Clean the area in front of the sensors ⇨ *page 132* and try to turn the system on again later.

If the malfunction remains, drive to an authorized Audi dealer or authorized Audi Service Facility immediately to have the malfunction corrected.

WARNING

- Observe the safety precautions and note the limits of the assist systems, sensors, and cameras ⇨ *page 129* to ⇨ *page 132*.
- The emergency assist is an assist system that should only be used in cases of emergency to take over control of the vehicle and bring it to a stop.

Tips

- If the emergency assist is switched off, it will switch on again automatically once the ignition is switched on again.
- Depending on the severity of the detected situation, not all safety measures will be initiated. Certain functions can be adjusted or skipped if necessary.

Parking and maneuvering

Introduction

Depending on the vehicle equipment, various parking aids will help you when parking and maneuvering.

Parking aid

The **parking aid plus** assists you while parking using audio and visual signals to warn you about objects detected in front of, behind, and next to* the vehicle ⇨ *page 161*.

The **rearview camera** shows the area behind the vehicle in the center display. The lines in the rearview camera image help you to park and maneuver ⇨ *page 163*.

The **peripheral cameras** are an addition to the rearview camera and help you to see various areas around the vehicle while parking and maneuvering ⇨ *page 163*.

The **rear cross-traffic assist** can warn you of approaching cross traffic when driving in reverse or exiting a parking space ⇨ *page 167*.

Assisted parking

Park assist plus helps you to locate suitable parking spaces and to park in them and exit them. The system controls the steering, gear selection, acceleration, and braking. The driver must always monitor the area around the vehicle and supervise the process of parking or exiting a parking space ⇨ *page 168*.

Possible settings

You can adjust parking aid functions in the **Parking aid** menu according to your preferences ⇨ *page 133*. Some settings are only available via  and under certain conditions.

- **Automatic activation** ⇨ *page 161*
- **Front and rear volume** ⇨ *page 162*
- **Entertainment fader** ⇨ *page 162*.
- **Clean rearview camera** ⇨ *page 164*
- **Trailer view** ⇨ *page 165*
- **View** ⇨ *page 166*
- **Rear cross-traffic assist** ⇨ *page 167*

WARNING

Observe the safety precautions and note the limits of the assist systems, sensors, and cameras ⇨ *page 129* to ⇨ *page 132*.

Tips

Audi recommends practicing parking in a traffic-free location or parking lot to become familiar with the systems. Practice parking in good light and weather conditions.

Parking aid plus

Activating and deactivating

Applies to: vehicles with parking aid plus



Fig. 119 Center console: parking aids button

General information

The parking aid assists when parking and maneuvering by providing warnings about obstacles. If the ultrasonic sensors on the vehicle ⇨ *page 130*, *fig. 92* detect an obstacle, the system will provide audio and visual warnings.

Activating and deactivating

Requirement: the vehicle speed must be under approximately 6 mph (10 km/h).

- ▶ Press the PWA or PWA button  in the center console.

Automatic activation

- ▶ The system activates automatically when reverse gear is engaged while the drive system is active, or

If **Automatic activation** is switched on ⇨ *page 133* in the **Parking aid** menu and if the vehicle approaches an obstacle when driving ▶

forward at speeds below approximately 6 mph (10 km/h), the parking aid will activate automatically. Audible signals will sound once the obstacle is within the sensor detection area.

Automatic deactivation

The distance indicator for the parking aid will deactivate automatically when driving forward faster than approximately 6 mph (10 km/h).

WARNING

Observe the safety precautions and note the limits of the assist systems, sensors, and cameras ⇒ *page 129* to ⇒ *page 132*.

Note

Keep enough distance from the curb to avoid damage to the rims.

Tips

- If the parking aid is deactivated, it can only be reactivated automatically when one of the following conditions is met:
 - The vehicle speed exceeds 6 mph (10 km/h)
 - The ignition is switched off and back on again
 - The parking brake is set and then released

Warnings

Applies to: vehicles with parking aid plus



Fig. 120 Center display: distance display

If the sensors detect an obstacle, audible and visual signals will warn you.

Visual warnings

The visual warnings in the center display help you to detect the critical vehicle area and to estimate the distance to an obstacle.

Red segments ① show detected obstacles that are in your vehicle's path. The red lines ② mark the expected direction of travel based on the steering angle. A white segment ③ indicates a detected obstacle that is outside of the vehicle's path. The closer your vehicle comes to the obstacle, the closer the segments will move to the vehicle. The collision area has been reached when the next to last segment is displayed. Obstacles in the collision area, including those outside of the vehicle's path, are shown in red. Do not continue driving farther.

Audio signals

The closer your vehicle gets to a detected obstacle, the shorter the time between the audible signals. A continuous tone sounds when an obstacle is less than approximately 1 foot (0.30 m) away from the front or rear of the vehicle. A continuous tone sounds when an obstacle is less than approximately 0.7 feet (0.20 m) away from the sides*¹⁾ of the vehicle. Do not continue driving forward or in reverse ⇒ .

- ▶ To deactivate audio signals when parking or exiting a parking space, press  in the center display. The audio signals will be automatically activated again the next time the parking aid is activated.

Adjusting the volume

You can adjust the volume to your preferences in the **Parking aid** menu ⇒ *page 133*. The settings depend on the vehicle equipment.

Possible settings:

Front volume - Volume for the front and side*¹⁾ area.

Rear volume – Volume for the rear area. ▶



¹⁾ In preparation at the time of printing.

Entertainment fader – The volume of the audio/video source is lowered when the parking aid is activated.

Error messages

If  appears, the sensor in the respective area or the speaker is faulty. Drive immediately to an authorized Audi dealer or authorized Audi Service Facility to have the malfunction repaired.

If  is displayed in the MMI, the ultrasonic sensor indicated is icy or dirty. Clean the area in front of the sensors ⇒ *page 132*.

If  or  is displayed when there is a malfunction, the parking aid functions may be unavailable or may be limited.

A message that indicates the cause and possible solution may appear with some displays. The weather conditions may be too poor or a sensor may be covered. Clean the area in front of the sensors ⇒ *page 132* and try to turn on the systems again later.

If the malfunction remains, drive to an authorized Audi dealer or authorized Audi Service Facility immediately to have the malfunction corrected.

 **WARNING**

- Observe the safety precautions and note the limits of the assist systems, sensors, and cameras ⇒ *page 129* to ⇒ *page 132*.
- Sensors and cameras have spots in which the surrounding area cannot be detected. Objects, animals, and people may only be detected with limitations or may not be detected at all. Always monitor the traffic and the vehicle's surroundings directly and do not become distracted.

 **Note**

Keep enough distance from the curb to avoid damage to the rims.

 **Tips**

- The segments in the side area*¹⁾ are detected and analyzed when passing. If you switch the ignition off and on again or open the door, or if the vehicle is stationary for a period of time, the surrounding area may have changed in the meantime. In this case, the area will appear black until the area has been detected and evaluated.
- If the distance to an obstacle remains constant, the volume of the distance warning gradually lowers after a few seconds until it is muted (this does not apply to the continuous tone). If the obstacle comes closer than it was before the sound was muted, the tone will sound again. If the obstacle becomes farther away than it was before the sound was muted, no tone will sound. Pay attention to the vehicle's surroundings when you start to drive.
- There is no distance warning for the rear and the sides*¹⁾ when trailer towing mode is detected. The front sensors remain activated. There is no guarantee the functions will be deactivated when using a retrofitted trailer hitch.

Rearview camera and peripheral cameras

Introduction

Applies to: vehicles with rearview camera/peripheral cameras

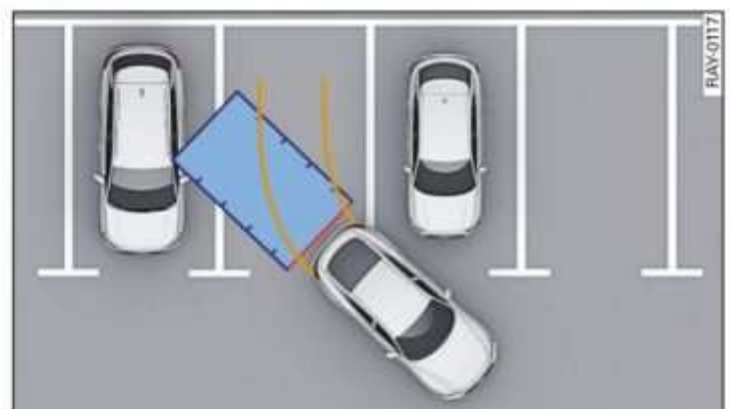

Fig. 121 Orientation line display when parking

¹⁾ In preparation at the time of printing.

Parking and maneuvering

Depending on the vehicle equipment, a rearview camera or multiple peripheral cameras may be available.

The **rearview camera** helps you to park or maneuver using the orientation lines.

The **peripheral cameras** expand the vehicle overview to include various views around the vehicle that can be selected.

WARNING

Observe the safety precautions and note the limits of the assist systems, sensors, and cameras ⇒ *page 129* to ⇒ *page 132*.

Activating and deactivating

Applies to: vehicles with rearview camera/peripheral cameras



Fig. 122 Center console: parking aids button

Activating and deactivating

- ▶ Press the **PWA** or **PWA** button **1** in the center console, or
- ▶ Press  on in the center display if the visual distance indicator ⇒ *page 162*, *fig. 120* is shown.

The system can be activated at low speeds, such when maneuvering.

Automatic activation

The system activates automatically when reverse gear is engaged while the drive system is active.

Automatic deactivation

The system will deactivate automatically once the vehicle exceeds a certain speed while driving forward.

WARNING

Observe the safety precautions and note the limits of the assist systems, sensors, and cameras ⇒ *page 129* to ⇒ *page 132*.

Clean rearview camera

Applies to: vehicles with rearview camera/peripheral cameras

Requirement: the rearview camera is activated or the **Rear*** or **Rear corner*** view is selected.

- ▶ Select  > **Clean rearview camera** in the center display when the parking aid is active.

WARNING

Observe the safety precautions and note the limits of the assist systems, sensors, and cameras ⇒ *page 129* to ⇒ *page 132*.

Warnings

Applies to: vehicles with rearview camera/peripheral cameras

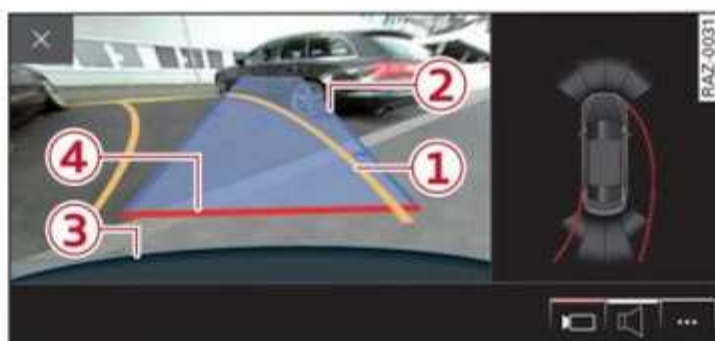
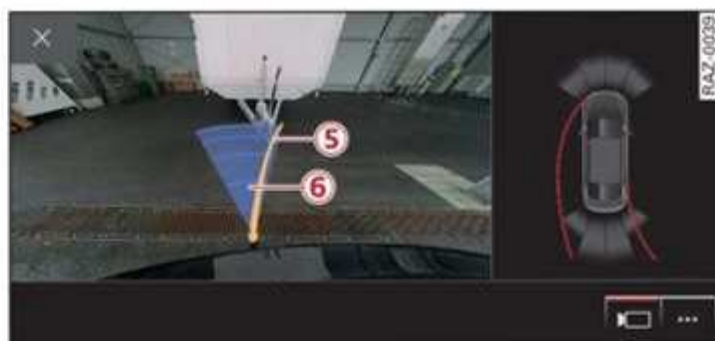



Fig. 123 Center display: aiming at a parking spot



Applies to: vehicles with trailer view
Fig. 124 Center display: trailer view

When parking with the rearview camera or peripheral camera, the parking aid audio and visual warnings* ⇒ *page 162* will also assist you.

Visual orientation lines

- 1** The orange orientation lines show the vehicle's direction of travel ⇒ . Turn the

steering wheel until the orange orientation lines align with the parking space.

- ② You can use the horizontal blue markings to help you estimate the distance to an obstacle. Each marking represents approximately 3 feet (1 meter). The blue surface is a static display and represents an extension of the vehicle perimeter to the rear.
- ③ You can recognize the rear bumper in the lower display.
- ④ You should stop driving in reverse when the red orientation line touches the edge of an object, at the latest.

Trailer view

Applies to: vehicles with trailer view

Requirement: the rearview camera or peripheral cameras are activated.

- Applies to: vehicles with peripheral cameras:
Switch to the **Rear** view ⇒ *page 166, fig. 125*.
- Select  > **Trailer view** in the center display when the parking aid is active.

With the trailer view ⇒ *fig. 124*, it will be easier for you to position your vehicle in front of a trailer. The orange orientation line ⑤ ⇒ *fig. 124* indicates the expected path toward the trailer hitch. Use the blue markings ⑥ to help you estimate the distance to the trailer hitch. Each marking represents approximately 1 foot (0.30 meters). The width of the blue surface represents the maximum steering wheel angle.

Symbols

Applies to: vehicles with peripheral cameras

If  is displayed and the display area represented by that symbol is not available, then the camera on the that side is not available. The power exterior mirrors may have been folded in or a door or the luggage compartment lid may have been opened.

If  is displayed, there is a system malfunction and the display area represented by that symbol is not available. The camera is not working in this area.

If one of the symbols continues to be displayed, drive immediately to an authorized Audi dealer or authorized Audi Service Facility to have the malfunction repaired.

WARNING

- Observe the safety precautions and note the limits of the assist systems, sensors, and cameras ⇒ *page 129* to ⇒ *page 132*.
- Sensors and cameras have spots in which the surrounding area cannot be detected. Objects, animals, and people may only be detected with limitations or may not be detected at all. Always monitor the traffic and the vehicle's surroundings directly and do not become distracted.

Note

- The orange orientation lines ① show the direction the rear of the vehicle will be traveling, based on the steering wheel angle. The front of the vehicle swings out more than the rear of the vehicle. Maintain plenty of distance so that an exterior mirror or a corner of the vehicle does not collide with any obstacles.
- Keep enough distance from the curb to avoid damage to the rims.
- Only use the images provided by the camera on the rear of the vehicle when the luggage compartment lid is completely closed. Make sure any objects you may have mounted on the luggage compartment lid do not block the rearview camera.

Tips

There is no distance warning for the rear and the sides*¹⁾ when trailer towing mode is detected. The front sensors remain activated. The visual display switches to trailer mode. There is no guarantee the functions will be deactivated when using a retrofitted trailer hitch.

¹⁾ In preparation at the time of printing.

Operating the peripheral cameras

Applies to: vehicles with peripheral cameras

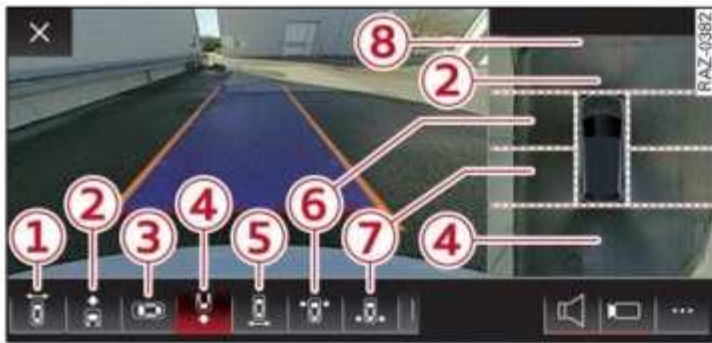

Fig. 125 Center display: peripheral cameras

On vehicles with peripheral cameras, you can select among different views.

Selecting the views

- ▶ To display the entire selection bar, tap the current view ① or swipe at the edge of the selection bar from left to right.

	Symbol/Description	Description
①	Front corner or Display selection bar	This view makes it easier to drive out of tight parking spaces or areas and intersections with poor visibility. It shows an almost 180° panorama view in front of the vehicle.
②	Front	This view assists you in using the full area for maneuvering in front of the vehicle.
③	Surroundings	This view helps you to maneuver and position the vehicle more precisely. The area around the vehicle is shown using the camera images. The vehicle image is shown by the system ⇨ ⚠.
④	Rear	This view assists you in using the full area for maneuvering behind the vehicle. This is the rearview camera image.
⑤	Rear corner	This view can assist you when driving out of tight parking spaces or areas with poor visibility. It shows an almost 180° panorama view behind the vehicle.
⑥	Front tires	This view helps you to see the distance between the front tires and the curb and the steering wheel angle when parking.
⑦	Rear tires	This view helps you to detect the distance between the rear wheels and the curb when parking.
⑧	Steering wheel angle	The red lines represent the estimated direction of travel based on the steering wheel angle ⇨ ⚠.

- ▶ To select a view, press ① - ⑦ or tap in an area to show the vehicle in the side view ¹⁾.

Selecting a view in the side area

The vehicle surroundings are shown in the side area of the display. You can adjust the view to your preferences in the **Parking aid** menu ⇨ *page 133*. You can switch between a visual display (**Graphic**) and the vehicle surroundings (**Camera**).

¹⁾ Requirement: The vehicle surroundings (**Camera**) is selected and visible in the **View** in the side area.

! WARNING

- Observe the safety precautions and note the limits of the assist systems, sensors, and cameras ⇒ *page 129* to ⇒ *page 132*.
- The **Surroundings** view is created from the individual camera images. The vehicle image is shown by the system. Objects and obstacles above the camera are not displayed.

! Note

Only use the images provided by the camera on the rear of the vehicle when the luggage compartment lid is completely closed. Make sure any objects you may have mounted on the luggage compartment lid do not block the rearview camera.

i Tips

- Depending on the selected gear, it will automatically switch between the **Front** and **Rear** views. If you switch the view manually, the automatic front/rear camera change will be temporarily deactivated.
- When first activated while a forward gear is engaged, the **Front corner** is displayed.

Rear cross-traffic assist

Description

Applies to: vehicles with rear cross-traffic assist



Fig. 126 Sensor detection range for rear cross-traffic assist

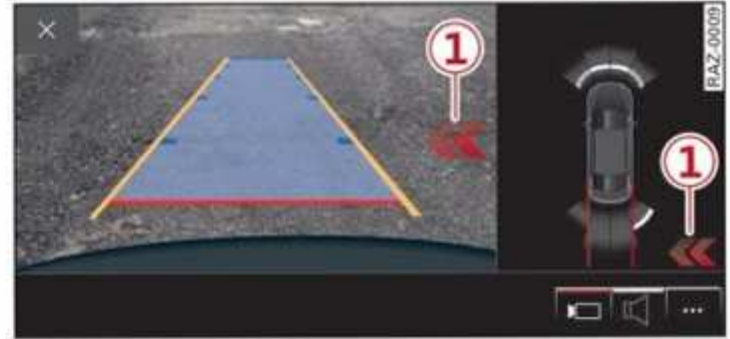

Fig. 127 Center display: rear cross-traffic assist display

General information

The rear cross-traffic assist monitors the area behind and next to the vehicle using radar sensors at the rear corners of the vehicle. The system can detect moving objects that are approaching, such as vehicles ⇒ *fig. 126*. A display in the MMI ① and various warnings provide assistance when exiting a parking space.

Requirements for using the rear cross-traffic assist:

- The parking aid is active ⇒ *page 161*.
- The speed while driving backwards is not higher than approximately 6 mph (10 km/h).

Displays, warnings, and braking



- **Display:** the display ① appears only when the parking aid is active. In vehicles with peripheral cameras, the display only appears in the **Rear** and **Rear corner** camera views. Arrows show the direction from which the cross traffic is approaching.
- **Audible warnings:** an audio signal may sound as an additional warning when driving in reverse.
- **Automatic brake activation:** if you do not react to a warning, a brief braking by the system can warn you of a potential collision with an approaching object.

The audible warning signal and the automatic brake activation occur only when driving in reverse.

Switching the rear cross-traffic assist on and off

You can turn the rear cross-traffic assist on or off in the **Parking aid** menu ⇒ *page 133*.

Messages

If , , or  is displayed when there is a malfunction, the rear cross traffic assist functions may be unavailable or may be limited.

A message that indicates the cause and possible solution may appear with some displays. The weather conditions may be too poor or a sensor may be covered. Clean the area of the sensors at the rear corners of the vehicle ⇒ *page 132*, *fig. 95* and try to turn the system on again later.

If the malfunction remains, drive to an authorized Audi dealer or authorized Audi Service Facility immediately to have the malfunction corrected.

WARNING

- Observe the safety precautions and note the limits of the assist systems, sensors, and cameras ⇒ *page 129* to ⇒ *page 132*.
- The rear cross-traffic assist will not provide alerts about people and cannot warn you about every type of approaching object, such as bicycles. Always monitor the traffic as well as the vehicle's surroundings with direct eye contact.
- The system may not react at all or it may not react on time when objects are approaching very quickly.
- The rear cross-traffic assist will not provide alerts if your vehicle is parallel parked or if your vehicle is pulled too far into the parking space so that it is hidden by adjacent vehicles.

Tips

- Once an automatic brake activation occurs, the system cannot initiate another activation for several seconds.
- System functions may not be available if the ESC is limited or switched off, or if there is a malfunction.
- If there is an audio warning signal from the rear cross-traffic assist, then the parking aid may not be able to provide audio warnings about detected obstacles under certain circumstances.

- The system is not available when the vehicle detects that you are towing a trailer. There is no guarantee the functions will switch off when using a retrofitted trailer hitch. Do not use these functions when towing a trailer.
- The system complies with United States FCC regulations and ISED regulations ⇒ *page 291*.
- The coverage areas of the sensors ⇒ *fig. 126* are diagrams and do not represent a true-to-scale image of the sensor ranges.

Assisted parking

General information

Applies to: vehicles with park assist plus

If your vehicle is equipped with park assist plus, the system will help you in finding suitable parking spaces. Parking spaces are measured using ultrasonic sensors on the sides of the vehicle.

The system helps with the process of parking or exiting a parking space while you monitor the vehicle's surroundings with the parking aids, cameras*, and direct eye contact.

WARNING

Observe the safety precautions and note the limits of the assist systems, sensors, and cameras ⇒ *page 129* to ⇒ *page 132*.

Options for parking and exiting parking spaces

Applies to: vehicles with park assist plus



Fig. 128 Parking options overview

The following parking options may be available, depending on the time of activation:

- After trying to park on your own ① - ④
⇒ page 169.
- After a prior parking space search ① - ③
⇒ page 169.

Parking options

- ① Backing into parallel parking spaces
- ② Backing into perpendicular parking spaces
- ③ Driving forward into perpendicular parking spaces that you have already driven past
- ④ Driving forward into perpendicular parking spaces

Options for exiting parking spaces

- ① Exiting parallel parking spaces

Activating after trying to park on your own

Applies to: vehicles with park assist plus

The system can be activated to complete a parking process if you have already driven forward or backward partially into a parking space.

Requirement: you have driven into the parking space on your own and the vehicle is far enough into the parking space that the system was able to measure the parking space.

- ▶ If necessary, apply the brakes until the vehicle comes to a stop.
- ▶ To start assisted parking, press **P** in the center display when the parking aid is active. The message **Park assist plus: to start parking, take your hands off the steering wheel and press "OK"** appears in the center display.
- ▶ Confirm the message in the center display and start the assisted parking process ⇒ page 171.

Parking space search

Applies to: vehicles with park assist plus



Fig. 129 Center display: activated parking space search

- ① Parking options display
- ② Arrows and symbols indicate the necessary actions, such as continuing to drive forward or applying the brakes
- ③ Parking space detected and selected by the system

Activating the parking space search

- ▶ To activate the parking space search when the parking aid is activated, press **P** in the center display.

The display for the parking space search appears in the center display ⇒ fig. 129.

Searching for parking spaces

- ▶ Drive forward to the row of parking spaces at a low speed. For the best parking results, the vehicle should be approximately 3 feet (1 m) from the row of parking spaces.
- ▶ The parking space search is first done on the side of your lane. To switch the side to park on, ▶

turn on the turn signal for the other side or press that side next to the vehicle in the center display.

Selecting the parking space

If the system finds a parking space that could be suitable for the vehicle length and width, it will be displayed. The system automatically suggests a parking option ①.

If the parking space allows different parking options, they can be selected manually. Press one of the suggested parking options ① in the center display.

Starting the parking process

To reach the correct starting position, follow the visual instructions in the center display ②. Once the vehicle has reached the correct position, a **P** will appear above the selected parking space ③.

- ▶ Keep the vehicle as parallel as possible to the parked vehicles or to the side of the road.
- ▶ Make sure that the parking space is suitable for your vehicle ⇒ .
- ▶ Start the assisted parking process ⇒ *page 171*.

Maneuvering area

The vehicle can go off course during the parking process ⇒ . If there are obstacles within the maneuvering area that block or endanger the parking process, for example on the opposite side of the street, a message may appear. You may need to drive farther forward and stay closer to the row of parking spaces.

WARNING

- Observe the safety precautions and note the limits of the assist systems, sensors, and cameras ⇒ *page 129* to ⇒ *page 132*.
- The driver is always responsible when entering or exiting a parking space and during similar maneuvers.
- Sensors and cameras have spots in which the surrounding area cannot be detected. Objects, animals, and people may only be detected with limitations or may not be detected at all. Always monitor the traffic and

the vehicle's surroundings directly and do not become distracted.

Note

- Parking spaces classified as suitable by the system may have been detected incorrectly. The driver must decide if the parking space displayed is suitable for the vehicle.
- Certain objects (such as trees and posts) or types of ground (such as gravel, snow, and ice) in the area of the parking space may result in the vehicle not being positioned as it normally would be at the end of the parking process. This increases the risk of collisions.

Tips

- If you did not drive past a suitable parking space too quickly, the system can also be activated afterwards by pressing **P** in the center display.
- The Electronic Stabilization Control (ESC) must not be switched off during the parking process. If the ESC intervenes, the parking process will be canceled.
- You cannot park with the parking assist systems when you are towing a trailer or have the connector inserted in the trailer socket.
- The system is not available when certain assist systems are switched on.
- If there are suitable parking spaces on both sides of the street, for example on a one-way street, you can change the side where the system is searching for parking spaces by activating the turn signal for the other side or by pressing on that side in the center display.
- The parking systems do not support assisted parking on steep inclines or on tight curves.

Park assist plus

General information

Applies to: vehicles with park assist plus

Park assist plus parks the vehicle after the parking space search and also exits parallel parking spaces. The driver will monitor the vehicle

surroundings while park assist plus will control the steering, acceleration, braking, and shifting gears.

! WARNING

- Observe the safety precautions and note the limits of the assist systems, sensors, and cameras ⇨ *page 129* to ⇨ *page 132*.
- The driver is always responsible when entering or exiting a parking space and during similar maneuvers.
- Do not use this function if the vehicle cannot move freely, for example when on a vehicle jack.
- Sensors and cameras have spots in which the surrounding area cannot be detected. Objects, animals, and people may only be detected with limitations or may not be detected at all. Always monitor the traffic and the vehicle's surroundings directly and do not become distracted.

! Note

- Do not use park assist plus when transporting cargo that extends outside of the vehicle or when snow chains are mounted.
- Park assist plus guides the vehicle either away from curbs or onto them if other vehicles are parked on the curb. Make sure that your vehicle's tires and rims are not damaged. Resume control of the vehicle in time or stop the process of parking or exiting the parking space.

i Tips

Follow the legal regulations in the country where you are operating the vehicle when using park assist plus. Park assist plus may be prohibited in some countries. The system may be unavailable in countries where it has been deactivated in order to comply with legal regulations. Data will not be transmitted to Audi. The driver is always responsible for adhering to the regulations applicable in the country where the vehicle is being operated.

Parking with park assist plus

Applies to: vehicles with park assist plus

Requirement: a suitable parking space must be found and selected ⇨ *page 168*. The vehicle must initially be stationary and the brakes must be pressed.

- ▶ Press the button in the center display to start the parking process.
- ▶ Remove your hands from the steering wheel.
- ▶ Pay attention to the path of the vehicle. When the traffic situation allows, release the brakes ⇨ **!**. The indicator light  in the center display shows that the park assist plus is active and that it is controlling the vehicle. An arrow on top of the vehicle roof indicates the current direction of travel.
- ▶ In situations where conditions are unclear, pause the parking process by applying the brakes until the vehicle is stationary. For example, this may be necessary if an obstacle appears or if the vehicle comes very close to an obstacle.
- ▶ To resume the parking process, release the brakes again. The remainder of the parking process will be recalculated based on the vehicle position.

End of the parking process

The parking process will end automatically once the vehicle has reached the end point in the parking space. After park assist plus finishes parking successfully, the parking lock will be engaged and the parking brake will be set.

Pause park assist plus ⇨ *page 173*.

! WARNING

- Observe the safety precautions and note the limits of the assist systems, sensors, and cameras ⇨ *page 129* to ⇨ *page 132*.
- Release the brakes while park assist plus is active only if you are sure that there are no obstacles in the vehicle's path or under the vehicle, and that no obstacles will enter the vehicle's path.

- Park assist plus is an assist system. The driver is still responsible for monitoring the vehicle's surroundings and preventing collisions when using the system.
- When using park assist plus to enter or exit a parking space, the steering wheel turns quickly on its own. Reaching into the steering wheel spokes while this is happening can result in injury.





Tips

- You can reduce the speed specified by the system at any time by pressing the brake pedal.
- The system can incorrectly interpret parking space barriers (such as parking curbs). Take over the parking process ⇒ *page 173* if the vehicle is not completely inside the parking space or if the vehicle tries to drive over the parking space barrier.

Exiting a parking space with park assist plus

Applies to: vehicles with park assist plus

If you parked the vehicle in a parallel parking space, park assist plus can help you to exit the space.

- ▶ Switch on the drive system.
- ▶ Press the  button in the center console.
- ▶ Press  in the center display when the parking aid is active.
- ▶ Wait until a message appears in the center display that requests you to select the direction in which to travel when exiting the parking space.
- ▶ Activate the turn signal on the desired side or press that side next to the vehicle in the center display.
- ▶ Press the button in the center display to start the process of exiting the parking space.
- ▶ Remove your hands from the steering wheel.
- ▶ Pay attention to the path of the vehicle. When the traffic situation allows, release the brakes ⇒ . The indicator light  in the center display shows that the park assist plus is active and that it is controlling the vehicle. An arrow on top of the vehicle roof indicates the current direction of travel.

- ▶ In situations where conditions are unclear, pause the process of exiting the parking space by applying the brakes until the vehicle is stationary. For example, this may be necessary if an obstacle appears or if the vehicle comes very close to an obstacle.
- ▶ To resume the process of exiting the parking space, release the brakes again.
- ▶ The process of exiting the parking space has ended if additional corrective movements are no longer necessary and the specified steering wheel angle is sufficient to drive out of the parking space. Resume control of the steering wheel ⇒ .

Pause park assist plus ⇒ *page 173*.

WARNING

- Observe the safety precautions and note the limits of the assist systems, sensors, and cameras ⇒ *page 129* to ⇒ *page 132*.
- Release the brakes while park assist plus is active only if you are sure that there are no obstacles in the vehicle's path or under the vehicle, and that no obstacles will enter the vehicle's path.
- Park assist plus is an assist system. The driver is still responsible for monitoring the vehicle's surroundings and preventing collisions when using the system.
- When using park assist plus to enter or exit a parking space, the steering wheel turns quickly on its own. Reaching into the steering wheel spokes while this is happening can result in injury.

Note

Resume steering immediately after the last corrective movement and the takeover prompt, so that the specified steering wheel angle is not recentered.

Tips

You can reduce the speed selected by the vehicle or stop the vehicle at any time by pressing the brake pedal.

Pausing park assist plus

Applies to: vehicles with park assist plus

You can pause park assist plus at any time by applying the brakes. To resume the process of parking or exiting the parking space, release the brakes again.

Canceling automatically

Park assist plus is canceled automatically among other things, if:

- You switch off the system
- You take over steering or press the brake pedal
- The time limit is exceeded
- An obstacle is detected
- The ESC intervenes

Resume control of the vehicle, end the process of parking or exiting the parking space manually, or:

You can resume the parking process in some situations. Press and hold the brake pedal and press **P** in the center display.



WARNING

Observe the safety precautions and note the limits of the assist systems, sensors, and cameras ⇒ *page 129* to ⇒ *page 132*.

Messages

Applies to: vehicles with park assist plus

If the **P_uoff**, **P_uoff** or **P** indicator light turns on, the park assist is not available or was interrupted.

A message that indicates the cause and possible solution may appear with some displays. The weather conditions may be too poor or a sensor may be covered. Clean the area in front of the sensors ⇒ *page 132* and try to turn the system on again later.

If the malfunction remains, drive to an authorized Audi dealer or authorized Audi Service Facility immediately to have the malfunction corrected.

Telephone

Introduction

Applies to: vehicles with telephone

You can operate various telephone functions easily through the MMI in your vehicle.

Depending on the country and the vehicle equipment, the following options may be available:

- Connecting a cell phone with Bluetooth
- Using two telephones
- Using the Audi phone box

WARNING

- Medical experts warn that mobile devices can interfere with the function of pacemakers. Always maintain a minimum distance of about 7.9 inches (20 cm) between the mobile device antennas and the pacemaker.
 - Do not carry the mobile device in a pocket directly over the pacemaker when the phone is switched on.
 - Switch the mobile device off immediately if you suspect it may be interfering with the pacemaker.
- Do not use the voice recognition system* ⇒ *page 27* in emergencies because your voice may change in stressful situations. The system may take longer to dial the number or may not be able to dial it at all. Dial the emergency number manually.
- Switch your mobile device off in areas where there is a risk of an explosion. These locations are not always clearly marked. This may include gas stations, fuel and chemical storage facilities or transport vehicles, or locations where fuel vapors (such as propane or gasoline vapor in vehicles or buildings), chemicals or large quantities of dust particles (such as flour, sawdust or metal) may be present in the air. This also applies to all other locations where you would normally switch your engine/motor off.
- The demands of traffic require full attention of all road users. Always read the chapter ⇒ *page 20, Traffic safety information.*

Note

Read the information about Audi connect, and be sure to note the connectivity costs section ⇒ *page 185.*

Tips

- The Bluetooth connection range is limited to inside the vehicle.
- A selection of supported Bluetooth devices can be found in the database for tested mobile devices at www.audi.com/bluetooth.

Setup

Connecting a mobile phone via Bluetooth

Applies to: vehicles with telephone

Requirement: the vehicle must be stationary. The Bluetooth settings must be open on your mobile device during the connection setup. The mobile device to be connected must not be actively connected to any other Bluetooth device. The MMI must only be connected to one mobile device.

- ▶ Enable the Bluetooth function and visibility on the MMI ⇒ *page 225* and the mobile phone.
- ▶ Applies to: MMI: Select on the home screen: **TELEPHONE.**
- ▶ Follow the system instructions. The available Bluetooth devices will be displayed after several seconds.
- ▶ Press on the desired mobile device in the list of displayed Bluetooth devices.
- ▶ To update the list, press .

A PIN for a secure Bluetooth connection will be generated.

- ▶ Confirm the PIN on your mobile device.
- ▶ Follow the system instructions.
- ▶ Pay attention to any other system prompts on the MMI and on your cell phone.

After connecting successfully

The cell phone contacts are automatically loaded in the MMI. This process can take several minutes, depending on the number of contacts.

Depending on your cell phone and the connection type, you can use the following functions: ▶

Using the hands-free system

Requirement: your cell phone must be connected to the MMI via a Bluetooth Hands Free Profile (Bluetooth HFP).

You can use the hands-free system. You can make calls using the antenna on your mobile device.

Sending and receiving messages

See ⇨ *page 183*.

Tips

- Pay attention to any system prompts displayed on your mobile device or the MMI, for example if the system should connect automatically in the future. Depending on the mobile device, you may need to download contacts and confirm access to your messages separately.
- You can also search for the MMI on your mobile device using the Bluetooth device search.
- You only have to pair your device one time. Bluetooth devices that are already paired will connect automatically to the MMI when the Bluetooth function is switched on and when they are within range. The last connected mobile device is given first priority.
- You can manage additional settings for connected mobile devices in the Connected devices menu ⇨ *page 227*.
- When leaving the vehicle, the Bluetooth connection to the mobile device will automatically disconnect. Depending on your mobile device, phone calls in progress may be automatically redirected from the MMI to your mobile device so that you can continue the call on your phone.

Using two telephones

Applies to: vehicles with telephone

You can connect two mobile phones to the MMI at the same time using the Bluetooth HFP, for example a business phone and a private phone. You can be reached in your vehicle through both mobile phones.

Applies to: mobile devices with Bluetooth Message Access Profile (MAP): You can send and receive messages with both mobile devices ⇨ *page 183*.

Connecting another mobile device

Requirement: a cell phone is connected to the MMI and vehicle is stationary. The Bluetooth settings must be open on your mobile device during the connection setup. The mobile device to be connected must not be actively connected to any other Bluetooth device.

- ▶ Enable the Bluetooth function and visibility on the MMI ⇨ *page 225* and the mobile phone.
- ▶ Applies to: MMI: Select on the home screen: **TELEPHONE** > , or
- ▶ Applies to: MMI: Select on the home screen: **SETTINGS** > **Connected devices** > **Telephone 1** or **Telephone 2** > **New connection**.
- ▶ Follow the system instructions. The available Bluetooth devices will be displayed after several seconds.
- ▶ Press on the desired mobile device in the list of displayed Bluetooth devices.
- ▶ To update the list, press .

A PIN for a secure Bluetooth connection will be generated.

- ▶ Confirm the PIN on your mobile device.
- ▶ Follow the system instructions.
- ▶ Pay attention to any other system prompts on the MMI and on your cell phone.

After connecting successfully

See ⇨ *page 174, After connecting successfully*.

Switching between two mobile devices

Requirement: phone 1 and phone 2 must be connected to the MMI.

- ▶ Applies to: MMI: Select on the home screen: **TELEPHONE** > .

Note

Read the information about Audi connect, and be sure to note the connectivity costs section ⇨ *page 185*.

Disconnecting a mobile device

Applies to: vehicles with telephone

- ▶ To disconnect a Bluetooth device from the MMI, use the Connected devices menu ⇒ page 227.

Using the Audi phone box

General information

Applies to: vehicles with Audi phone box/Audi phone box light

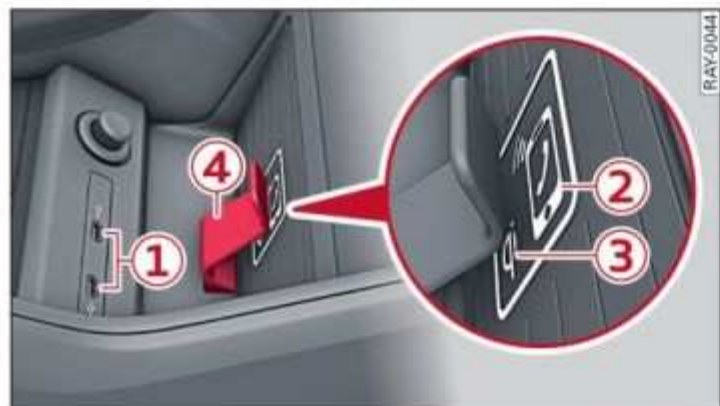

Fig. 130 Front center console: Audi phone box with holder and connections

Depending on vehicle equipment, you may be able to use the following functions with the Audi phone box:

- Make phone calls using the vehicle's exterior antenna
- Charge a mobile device using the USB input
- Charge a mobile device wirelessly
- Reminder signal

Limitations

In some situations, the functions of the Audi phone box may be limited or temporarily unavailable. For example, this may happen if

- There is one more than mobile device in the Audi phone box
- The mobile device is located in a bag or a protective case
- There are objects between the Audi phone box and the mobile device
- The mobile device is not positioned in the center of the Audi phone box

WARNING

- Loose objects can be thrown around the vehicle interior during sudden driving or brak-

ing maneuvers, which increases the risk of an accident. Store objects securely while driving.

- Do not allow the visual or audio signals from a mobile device to distract you from traffic, because this increases the risk of an accident. Operate the mobile device only via the MMI.

Note

Applicable to U.S.A.

Operation of the Audi phone box is subject to the following requirements of the Federal Communications Commission:

- This is a CONSUMER device.
- BEFORE USE, you MUST REGISTER THIS DEVICE with your wireless provider and have your provider's consent. Most wireless providers consent to the use of signal boosters. Some providers may not consent to the use of this device on their network. If you are unsure, contact your service provider.
- You MUST operate this device with approved antennas and cables as specified by the manufacturer. Antennas MUST be installed at least 20 cm (8 inches) from any person.
- You MUST cease operating this device immediately if requested by the FCC or a licensed wireless service provider.
- WARNING: E911 location information may not be provided or may be inaccurate for calls served by using this device.

Note

Applicable to Canada

In Canada, operation of a Zone Enhancer, such as an Audi phone box, is subject to the following requirements of the Innovation, Science and Economic Development Canada (ISED):

- This is a CONSUMER device.
- BEFORE USE, you MUST meet all requirements set out in CPC-2-1-05. At the time of printing this user manual, the CPC-2-1-05 client procedures circular of ISED Canada was available at the following web page: ▶

<http://www.ic.gc.ca/eic/site/smt-gst.nsf/eng/sf08942.html>.

- You **MUST** operate this device with approved antennas and cables as specified by the manufacturer. Antennas **MUST NOT** be installed within 20 cm of any person.
- You **MUST** cease operating this device immediately if requested by ISED or a licensed wireless service provider.
- **WARNING:** E911 location information may not be provided or may be inaccurate for calls served by using this device.

Tips



The system complies with United States FCC regulations and ISED regulations ⇒ *page 291*.

Making phone calls using the exterior antenna

Applies to: vehicles with Audi phone box

With the Audi phone box, you can make calls using the exterior antenna on the vehicle. Using the exterior antenna helps when there is a low signal and also provides better reception quality.

Requirement: the ignition must be switched on.

- ▶ Open the holder  ⇒ *page 176, fig. 130* in the Audi phone box.
- ▶ To make phone calls through the vehicle's exterior antenna using your mobile device, lay your device with the rear side against the phone symbol  in the center of the Audi phone box and holder .

Charging the battery using the USB input

Applies to: vehicles with Audi phone box/Audi phone box light

You can charge your mobile device using a special USB adapter with the Audi phone box ⇒ *page 213*.

Requirement: the ignition must be switched on.

- ▶ To charge your mobile device via USB, connect it to the USB input  ⇒ *page 176, fig. 130*.

Tips





- You can purchase a USB adapter from an authorized Audi dealer or authorized Audi Service Facility, or at specialty stores.
- Audi recommends using Audi Genuine Accessories. Audi has verified their reliability, safety, and suitability.

Charging a mobile device wirelessly

Applies to: vehicles with Audi phone box/Audi phone box light

You can charge your mobile device wirelessly using the Audi phone box.

Requirement: the ignition must be switched on. Your mobile device must meet the Qi standard.

- ▶ Make sure that the wireless charging function is switched on:
- ▶ Applies to: MMI: Select on the home screen: **SETTINGS > General > Reminder signal and mobile device charging**.
- ▶ Switch the **Mobile device wireless charging** function on.
- ▶ Open the holder  ⇒ *page 176, fig. 130* in the Audi phone box.
- ▶ To charge your mobile device wirelessly, lay your device with the rear side against the  symbol  between the Audi phone box and holder .

WARNING

- The mobile device may become hot during wireless charging. Pay attention to the temperature of your mobile device and be careful when removing it from the Audi phone box.
- An alternating magnetic field is used for wireless charging. Maintain a minimum distance of approximately 2.4 inches (6 cm) to the Audi phone box charging plate. The thresholds for prolonged exposure at this distance comply with ICNIRP1998. Therefore, interactions such as irritation of sensory organs, malfunctions of active medical implants (such as pacemakers, infusion pumps, or neurostimulators) or effects on passive medical implants (such as prosthetic limbs) is highly unlikely. If you have a

medical implant, seek medical advice from a specialist if you have any questions. You can also switch the function for wireless charging in the Audi phone box on and off. You can continue to charge your mobile device using a cable connection.

i Tips

- The maximum charging output is 5 W.
- The charging time and temperature will vary depending on the mobile device being used.

Mobile device reminder signal

Applies to: vehicles with Audi phone box/Audi phone box light

When the device reminder signal is switched on, you will be notified that your mobile device is still in the Audi phone box when you leave the vehicle.

Requirement: your mobile device must be located in the Audi phone box (if Qi-capable) or connected to the USB port with charging function using a USB adapter, and the smartphone interface must be active or your iPhone must be connected to the MMI via Bluetooth and charging using a USB adapter connected to the USB port with charging function.

- Applies to: MMI: Select on the home screen: **SETTINGS > General > Reminder signal and mobile device charging.**

The following settings may be available, depending on vehicle equipment:

- **Signal tone**
- **Off**

Spoken cue

this setting is switched on at the factory.

Mobile device notes: reminder, charge level

When this function is switched on, the charge status of your mobile device is displayed. You will also be reminded not to forget your mobile device when leaving the vehicle.

Using the telephone

Accessing the telephone functions

Applies to: vehicles with telephone



Fig. 131 Center display: selection menu

Requirement: a mobile device must be connected to the MMI.

- Applies to: MMI: Select on the home screen: **TELEPHONE.**

Possible telephone functions:

①	Search	
②	Call list	178
③	Favorites	179
④	Contacts	179
⑤	Voicemail	180
⑥	Dial phone number	180
⑦	Switch telephones	182

Managing call lists

Applies to: vehicles with telephone



Fig. 132 Center display: call list

Opening call lists using the MMI

- Applies to: MMI: Select on the home screen: **TELEPHONE > Call list.**

Opening call lists using the multifunction steering wheel

- Select in the instrument cluster: Telephone tab > button > **Call list.**

Possible call list symbols:

- ① Missed calls
- ② Dialed numbers
- ③ Accepted calls
- ④ Editing a telephone number
- ⑤ Display business card 180
- ⑥ Number of interactions with a contact

If more than one interaction with a contact or number has taken place, the last one is displayed in the form of an arrow ①, ②, or ③.

Call list options

Press and hold a contact or a phone number in the list until the **Options** menu appears.

Depending on the vehicle equipment and your mobile phone, the following options may be available:

- **Store as favorite** ⇨ *page 179*.
- **Send a text** ⇨ *page 183*.
- **Send e-mail** ⇨ *page 183*.

Edit number

Edit a phone number before dialing it.

Show history

Requirement: you must have had more than one interaction with a contact.

All interactions with a contact or a number are displayed.

Managing favorites

Applies to: vehicles with telephone

You can store contacts for all connected mobile devices as shortcuts in the favorites list.

Selecting favorites using the MMI

- ▶ Applies to: MMI: Select on the home screen: **TELEPHONE > Favorites**.

Opening favorites using the multifunction steering wheel

- ▶ Select in the instrument cluster: Telephone tab >  button > **Favorites**.

Storing favorites

- ▶ Press ☆ ⇨ *page 180* in the business card, or
- ▶ Press **Store as favorite** in the options ⇨ *page 178*.

Deleting favorites

- ▶ Press ★ ⇨ *page 180* in the business card, or
- ▶ Select: **Favorites** >  > *one or multiple favorites* or **Select all > Delete > (Done)**.

Tips

The favorites can only be edited via the MMI.

Managing the directory

Applies to: vehicles with telephone

You can manage up to four directories in the MMI.

Requirement: a mobile device must be connected to the MMI.

Opening the directory

- ▶ Applies to: MMI: Select on the home screen: **TELEPHONE > Contacts**.

The contacts will be displayed. You can change the sort order ⇨ *page 182*, **Sort order**.

Deleting imported contacts

Requirement: you must have imported at least one contact ⇨ *page 182*.

- ▶ Select: **Contacts** >  > *one or more text messages* > **Delete > (Done)**. The imported contacts are deleted.

Directory options

- ▶ Press and hold a contact in the directory until the **Options** menu appears.

Depending on the vehicle equipment and your mobile phone, the following options may be available:

- **Store as favorite** ⇨ *page 179*.
- **Send contact**: you can select **Text message** or **E-mail** ⇨ *page 183*.
- **Send a text** ⇨ *page 183*.
- **Send e-mail** ⇨ *page 183*.



Tips

- Pay attention to any synchronization prompts on your mobile device when downloading contacts.
- The contacts from the mobile device may not be transferred in alphabetical order. If there are too many entries, contacts with different first letters may be missing in the MMI.
- Only the contacts from the active connected mobile device are displayed.
- The contacts in the local MMI memory are always visible and can be accessed by other persons.
- After switching off the ignition and exiting the vehicle, the mobile device directory will be updated when the MMI is started again if the mobile device is within range and the Bluetooth function is switched on in the mobile device and the MMI.
- Only the contacts in the local MMI memory can be deleted.



Opening business cards

Applies to: vehicles with telephone

The business card shows you details about a contact.

- ▶ To open a business card, press on a contact in the directory, or
- ▶ Press  in the call list  ⇒ *page 178, fig. 132.*

Possible options in the business card:

- ▶ **Call:** press on a phone number.
- ▶ **Storing a favorite:** press .
- ▶ **Deleting a favorite:** press .
- ▶ **Sending a text message:** press .
- ▶ **Starting navigation:** press on an address.
- ▶ **Sending an e-mail:** press on an e-mail address.
- ▶ **Send contact:** you can select **Text message** or **E-mail** ⇒ *page 183.*

Listening to voicemail

Applies to: vehicles with telephone

Calling voicemail

- ▶ Applies to: MMI: Select on the home screen: **TELEPHONE > Voicemail.**

Entering the voicemail number

Requirement: there must be no voicemail number stored.

- ▶ Enter the desired number.
- ▶ Press **OK**.

Dialing the voicemail number

Requirement: a voicemail number must be stored.

- ▶ Press **Voicemail**. The call begins immediately.

Tips

This service must be set up and activated by the mobile phone service provider.

Dialing a telephone number

Applies to: vehicles with telephone

Depending on the vehicle equipment, you may have the following options for dialing a phone number:

- Using text input in the MMI ⇒ *page 24.*
- Using voice operation ⇒ *page 27.*

Call options

Applies to: vehicles with telephone

- ▶ To accept or end a call, press the  button on the multifunction steering wheel. Operating ⇒ *page 14* and ⇒ *page 30.*

Depending on your mobile device, the following options may be available in the MMI when there is an incoming call:

- **Answer**
- **Decline**
- **Message**

If you exit the vehicle during a phone call, the Bluetooth connection will be disconnected. Depending on your mobile device, phone calls in progress may be automatically transferred from the MMI to your mobile device.

Tips

The radio or media playback is muted during a phone call.

During a phone call

Applies to: vehicles with telephone

Depending on your mobile device and the type of connection, the following options may be available during a call:

- **End call**
- **Mute**

Sending a tone sequence

Press **Numbers**. You can enter tone sequences (DTMF) and send them to the other party on the call.

Hold

Puts the current call on hold. To resume the call, press **Resume**.

Answering an incoming call

One of these options will be available, depending on the mobile phone service provider:

- **Answer**: the current phone call will be put on hold. The incoming call will be answered.
- **Replace**: the active call will be replaced with the incoming call.

Declining an incoming call

If you select **Decline**, the incoming call will be declined.

Conference

Requirement: two phone calls must be in progress.

Depending on your mobile phone service provider, you can add a call on hold and up to five active callers to a conference call.

Swap call

Requirement: two phone calls must be in progress.

You can alternate between two phone calls.

Additional call options

Press **More**.

Depending on the mobile device being used and the type of connection, the following options may be available:

Transfer call to mobile device

Transfer the current call to your mobile device or Bluetooth headset*.

Switch to hands-free

Transfer the current call from your mobile device to the MMI.

Add call

You can start a new call. The current call will be put on hold.

Remove conference member

You can remove conference call members individually when a conference call is active.

Microph. input

You can adjust the input level of the microphone using the slider.

Tips

The call waiting function must be activated in your mobile device to be alerted about an incoming call during an active call.

Making an emergency call

Applies to: vehicles with telephone

Requirement: a mobile device must be connected to the MMI.

- ▶ Applies to: MMI: Select on the home screen: **TELEPHONE > Dial phone number > the local emergency call number (for example, 911) > Dial.**

WARNING

- Because your phone works with radio signals, a connection cannot be guaranteed under all circumstances. Do not rely on only your phone when it comes to essential communication (such as during a medical emergency).
- Always follow the instructions given by the emergency personnel during an emergency call and only end the call when they instruct you to do so.

Settings

Telephone settings

Applies to: vehicles with telephone

- ▶ Applies to: MMI: Select on the home screen:
TELEPHONE >

The following options may be possible, depending on your mobile device:

- **Decline with text message**
- **Edit voicemail number**

Switching between two mobile devices

Requirement: phone 1 and phone 2 must be connected to the MMI.

Switch telephones: the device name of the available mobile device is displayed. You can switch the phone by pressing the button.

Ringtone and volume settings

- **Ringtone and message volume:** you can adjust the volume using the slider.
- **Ringtone:** select a ringtone from the list.
- **Microphone input level:** you can adjust the input level of the microphone using the slider.

Data module serial number (IMEI)

Applies to: vehicles with data module

The serial number (IMEI) will be displayed.

Contact settings

Applies to: vehicles with telephone

- ▶ Applies to: MMI: Select on the home screen:
TELEPHONE > **Contacts** >

Switching between two mobile devices

Requirement: phone 1 and phone 2 must be connected to the MMI.

Switch telephones: the device name of the available mobile device is displayed. You can switch the phone by pressing the button.

The directory for the selected phone will be displayed.

Hide grayed-out contacts

When this function is switched on, contacts that have no phone numbers stored for them will be hidden.

Sort order

You can sort the contacts by **Last name** or **First name**.

Download contacts

Requirement: a mobile device must be connected to the MMI.

To update the contacts in the MMI, you can manually download your mobile device contacts. Depending on the mobile device, you may need to disconnect and reconnect the Bluetooth connection to update the contacts.

Importing and exporting contacts

Requirement: a USB storage device is connected to a USB port with charging function ⇨ *page 213*.

Contacts in vCard format (.vcf) can be imported or exported from the MMI.

- **Importing contacts from a storage device:** Requirement: the USB storage device must contain contacts in the vCard format. They must not be located in sub-folders. Select: > **Search for import data** > **USB device 1/USB device 2** > *desired contacts* or **Select all** > **Start import**.
- **Exporting contacts to a storage medium:** Requirement: you must have a contact imported. Select: **Export contacts** > **Find exporting source** > **USB device 1/USB device 2** > *desired contacts* or **Select all** > **Start export**.

Tips

- The imported contacts are stored in the local MMI memory.
- There should be no other files or folders on the storage medium containing the contacts to be imported.
- Contacts that were downloaded from a mobile device cannot be exported.
- Apple devices and MTP devices (such as smartphones) are not recognized as USB storage devices.

Messages

Text messages

Applies to: vehicles with telephone

Requirement: your mobile device must be connected to the MMI via Bluetooth Message Access Profile (Bluetooth MAP).

- ▶ Applies to: MMI: Select on the home screen: **MESSAGES** > (☒) > **Text message (telephone 1)/Text message (telephone 2)**.

The following functions are available:

- **New text message***
- **Inbox**
- **Sent**
- **Outbox***
- **Drafts***
- **Deleted**

User defined*

If necessary, user-defined folders will be copied to your mobile device.

Message options

Press on a text message.

Depending on the country, the following options may be available:

- **Read out**
- **Reply**
- **Forward**
- **More**

To switch between messages, press < or >.

Press **More**. Depending on your mobile device and the selected mailbox, additional options may be available:

- **Call**
- **Forward**
- **Navigate**
- **Extract numbers**
- **Send again**

Settings

Press ⚙.

New text message notification

When the function is switched on, an envelope ☒ in the MMI status bar will indicate when there is a new text message.

Tips

Only new received messages may be displayed depending on your mobile device.

E-mail

Applies to: vehicles with telephone and e-mail

Requirement: your mobile device must be connected to the MMI via Bluetooth Message Access Profile (Bluetooth MAP).

- ▶ Applies to: MMI: Select on the home screen: **MESSAGES** > (☒) > **E-mail (telephone 1)/E-mail (telephone 2)**.

The following functions are available:

- **New e-mail**
- **Inbox**
- **Sent**
- **Outbox**
- **Drafts***
- **Deleted***

User defined*

If necessary, user-defined folders will be copied to your mobile device.

Message options

Press on an e-mail.

Depending on the country, the following options may be available:

- **Read out**
- **Reply**
- **Reply all**
- **Forward**
- **More**

To switch between messages, press < or >.

Press **More**. Depending on your mobile device and the selected mailbox, additional options may be available:

- **Call**

- Forward
- Extract e-mail
- Navigate
- Extract numbers
- Show all recipients
- Send again

Settings

Press .

New e-mail notification

When the function is switched on, an envelope  in the MMI status bar will indicate when there is a new e-mail.

Troubleshooting

Applies to: vehicles with telephone

The information that follows lists some troubleshooting options. They depend on the equipment.

Problem	Solution
Pairing the mobile device to the MMI failed.	Make sure the requirements for connecting a mobile phone have been met \Rightarrow page 174, or make sure you did not accidentally decline the PIN for establishing a connection on your mobile phone. If necessary, repeat the pairing process \Rightarrow page 174.
After pairing, not all contacts or no contacts have been loaded into the MMI.	Avoid using special characters in names. Avoid using contact groups on your mobile device. Check for prompts on your mobile device when connecting via Bluetooth.
Certain telephone functions are grayed out or not available.	The telephone functions depend on the mobile device service provider and the mobile device you are using.
Some telephone functions may be switched off or not available, even though the mobile device is supported.	Check if the Bluetooth settings on your cell phone are limited or individual Bluetooth settings are deactivated. This may be the case with business cell phones.
The MESSAGES menu is not available.	Make sure your mobile device has an option to show messages option and that it is enabled.
Wireless cell phone charging is not working or is interrupted.	Check if wireless charging with the Audi phone box is switched on. Check if your mobile device is Qi-capable. Make sure your mobile device is positioned correctly in the Audi phone box \Rightarrow page 176 and that there are no objects located between the phone box and the phone.

Note

Read the information about Audi connect, and be sure to note the connectivity costs section \Rightarrow page 185.

Tips

Only new received messages may be displayed depending on your mobile device.

Audi connect

General information

Applies to: vehicles with Audi connect

Depending on the country and the vehicle equipment, the following functions may be available:

- Audi connect Infotainment
- Audi connect vehicle control

WARNING

- To reduce the risk of an accident, only use Audi connect services and the Wi-Fi hotspot only if the traffic situation permits it. Read and follow the guidelines provided in ⇒ *page 20, Traffic safety information*.
- It is only safe to use tablets, laptops, mobile devices and other similar devices when the vehicle is stationary because, like all loose objects, they could be thrown around the inside of the vehicle in a crash and cause serious injuries. Store these types of devices securely while driving. Also read the warnings in the chapter ⇒ *page 68*.

Note

- The connection costs of Audi connect Infotainment services are included in the price of Audi connect Infotainment during the subscription period with some exceptions. Please note that there may be additional charges when using some services. For example, this applies to online radio/podcasts, additional online data, or for Internet connections and services that use the Wi-Fi hotspot. Depending on the country, data plans may need to be purchased for these Internet connections and services ⇒ *page 188*. For additional information, see my.audi.com.
- In certain situations, the Wi-Fi hotspot data connection may be established as a replacement for the SIM card on your Wi-Fi device. This feature depends on the configuration of your Wi-Fi device and operating system. This could result in fees depending on your cell phone service provider, especially if you are using this feature while abroad. A flat

rate data plan is strongly recommended. For more information, contact your cell phone service provider or refer to the owner's manual for your Wi-Fi device.

- You are responsible for all precautions taken for data protection, anti-virus protection, and protection against loss of data on mobile devices that are used, for example, to access the Internet through the Wi-Fi hotspot.
- In areas with poor GPS reception or outside the coverage range of the respective cell phone service provider, some functions and/or services may not be available, it may not be possible to send or receive data, or functionality may be limited.

Tips

- The availability of services depends on the subscription.
- Audi merely provides access to third party services through the MMI and does not assume any responsibility for the content and availability of these services.
- Use of the most up-to-date mobile network standard is not available in every country. Contact an authorized Audi dealer or authorized Audi Service Facility or your cell phone service provider for additional information.
- Availability, scope, providers, screen display, and costs of services may vary depending on the country, model, model year, end device and rates.
- All services/apps can be modified, activated/deactivated, renamed, and enhanced without further notification.
- Depending on the country and model there may be an app other than the “myAudi app” available for your vehicle. For additional information, see my.audi.com.

Audi connect Infotainment

Description

Applies to: vehicles with Audi connect Infotainment

With Audi connect Infotainment services, online information is transmitted directly to the vehicle.

An Internet connection is required to use Audi connect Infotainment. The Internet connection is established using the embedded SIM card (eSIM).

! WARNING

Always follow the information found in  in *General information on page 185*.

! Note

Always follow the information found in  in *General information on page 185*.

Embedded SIM card

Applies to: vehicles with Audi connect Infotainment and an embedded SIM card

The data connection for Audi connect Infotainment services is made through an embedded SIM card (eSIM card) that is installed in the vehicle. You can use the Audi connect Infotainment services immediately.

! Note

Always follow the information found in  in *General information on page 185*.

Using a Wi-Fi hotspot

Applies to: vehicles with Wi-Fi hotspot

You can connect up to eight Wi-Fi devices (such as smartphones) with the MMI Wi-Fi hotspot. If the MMI is connected to the Internet \Rightarrow *page 186*, the connected Wi-Fi devices can also use the MMI's Internet connection.

Requirement: the ignition must be switched on. A data plan must be available \Rightarrow *page 188*.

- Applies to: MMI: Select on the home screen: **SETTINGS > Connection settings > Wi-Fi** Switch on the Wi-Fi hotspot.

- Applies to: MMI: Select on the home screen: **SETTINGS > Connection settings > Wi-Fi > Wi-Fi hotspot settings**. The access data for the Wi-Fi hotspot is displayed.
- Switch the Wi-Fi function on in your mobile device and connect it to the MMI Wi-Fi hotspot using the authentication data that is shown.
- Follow any additional system prompts on your Wi-Fi device if necessary.

Your device is successfully connected with the MMI's Wi-Fi hotspot.

! WARNING

Always follow the information found in  in *General information on page 185*.

! Note

Always follow the information found in  in *General information on page 185*.

i Tips

The system complies with United States FCC regulations and ISED regulations \Rightarrow *page 291*.

Audi connect Infotainment services

Configuration

Applies to: vehicles with Audi connect Infotainment

Some Audi connect Infotainment services must be configured through your personal myAudi account at my.audi.com before using them for the first time.

i Tips

- A myAudi user must be logged in for some Audi connect Infotainment services.
- Some Audi connect Infotainment services must be activated at my.audi.com.
- Depending on the country, you may be able to use an Audi app or my.audi.com.
- For detailed information on configuration, visit my.audi.com.

Services

Applies to: vehicles with Audi connect Infotainment

Depending on the country and the vehicle equipment, the following services may be available:

Weather information

Applies to: MMI

▶ Press **WEATHER** on the home screen.



Editing settings: Select: **WEATHER** > .

- ▶ To display the weather for a location, press on a location in the list.
- ▶ To display the weather for your current location, press on the location that is marked with the crosshairs.

Requirement: route guidance must be active.

- ▶ To display the weather at your destination, press on the location that is marked with the flag .

Adding a location: select: **WEATHER** >  > **In a new city** > *a location*.

Removing a location: select: **WEATHER** >  >  > *one or more locations* or **Select all** > **Delete**.

Online news

▶ Applies to: MMI: Select on the home screen: **NEWS**.

Access to the calendar

Requirement: the myAudi app must be installed and open on your mobile device. Access to your calendar must be enabled on your mobile device. You must be logged into the myAudi app with your myAudi login data and you must have selected your vehicle. The Wi-Fi function on your mobile device and the MMI must be enabled and your mobile device must be paired to the MMI Wi-Fi hotspot ⇨ *page 188, Wi-Fi*.

You can display the your mobile device calendar on the MMI.

▶ Applies to: MMI: Select on the home screen: **CALENDAR**.

WARNING

Always follow the information found in ⇨  in *General information on page 185*.

Note

Always follow the information found in ⇨  in *General information on page 185*.

Audi connect vehicle control services

Services

Applies to: vehicles with Audi connect vehicle control

Using Audi connect vehicle control services, you can perform tasks such as viewing data about your vehicle or control vehicle functions remotely.

You can view and use services available for your vehicle at my.audi.com or through the myAudi app.

Information about the services and the corresponding app was accurate at the time this manual was printed. The scope of services depends on the country and equipment. There may be changes over the service life of the vehicle.

WARNING

- Always follow the information found in ⇨  in *General information on page 185*.
- Driver messages, text messages, and illuminated warning and indicator lights in the vehicle always take priority over information from the Audi connect services. The information displayed by the Audi connect services should not cause you to take safety risks. This can result in the vehicle breaking down in traffic and to serious injuries or accidents.

Tips

- Accessing specific data or controlling functions remotely depends on the charge level of the vehicle battery. Therefore, these functions only have limited availability after switching off the ignition.
- An eSIM card establishes the Internet connection for Audi connect vehicle control services. The costs for this are included in the price of Audi connect vehicle control services. The mobile phone network, for

example, must be available to use these services.

Setup

Applies to: vehicles with Audi connect vehicle control

Create a myAudi account by registering in the myAudi app or at my.audi.com, depending on your country.

- ▶ Set the key user ⇒ page 32.
- ▶ Install the myAudi app on your mobile device and log in with your access information.

Tips

Some services require you to enter a 4-digit PIN that you set up during registration.

Settings

Wi-Fi

Applies to: vehicles with Wi-Fi hotspot

Requirement: the ignition must be switched on.

- ▶ Applies to: MMI: Select on the home screen: **SETTINGS > Connection settings > Wi-Fi**

Depending on the country and the vehicle equipment, the following functions may be available:

Wi-Fi

When the function is switched on, the MMI's Wi-Fi hotspot is active and Wi-Fi devices can be connected to the hotspot.

Wi-Fi hotspot settings

The Wi-Fi connection between the MMI and your Wi-Fi device is encrypted. You can change the following information if needed.

- **Access point (SSID):** name of the Wi-Fi hotspot.
- **Password:** an initial password was set at the factory in the MMI. Audi recommends changing the initial password. Only use secure passwords that conform to the general guidelines for secure passwords. For more information, refer to

reputable and current sources on password security.

Allow data connection through Wi-Fi

When the function is switched on, mobile devices can use the Internet connection through the Wi-Fi hotspot. A data plan is needed to do this.

WARNING

Always follow the information found in ⇒  in *General information on page 185.*

Note

Always follow the information found in ⇒  in *General information on page 185.*

Tips

The *name of the Wi-Fi hotspot* and the *Bluetooth name* are automatically compared when there are changes.

Data plans¹⁾

Applies to: vehicles with Audi connect

Data plans must be purchased in order to use certain services ⇒  in *General information on page 185.*

You can purchase data plans at my.audi.com.

WARNING

Always follow the information found in ⇒  in *General information on page 185.*

Note

Always follow the information found in ⇒  in *General information on page 185.*

Tips

- Depending on the country, you may be able to use the myAudi app or my.audi.com.
- Depending on the country, there may be restrictions on the use of data plans (such as mobile phone service providers) when driving in other countries.

¹⁾ Not available in every market.

– If selling your vehicle, you should delete the vehicle from the customer portal for the cell

phone service provider to avoid being charged for additional purchases.

Troubleshooting

Applies to: vehicles with Audi connect Infotainment

The information that follows lists some troubleshooting options. They depend on the equipment.

Problem	Solution
Audi connect Infotainment services: individual Audi connect Infotainment services are grayed out or not available.	Some Audi connect Infotainment services must be activated or configured through your personal myAudi account before using them for the first time. You can find detailed information online at my.audi.com .
Wi-Fi hotspot: it is not possible to connect through Wi-Fi.	Check if Wi-Fi is activated in the MMI ⇨ <i>page 188</i> . Delete all existing Wi-Fi connections on your mobile device and restart it.

Emergency call

Overview

Applies to: vehicles with emergency call function

An emergency call is a combination of data transmission and a phone call. Your vehicle uses data transmission to forward important information, such as the vehicle and position data, to an emergency call center.

Depending on the country and the vehicle equipment, the following functions may be available:

With the **emergency call**, you can call for help in dangerous situations as quickly as possible. Use this function when emergency help is needed ⇒ *page 190*.

- Audi connect emergency call (TPS emergency call). This eCall system uses third party emergency call centers, and if necessary, public emergency call centers.

With **online roadside assistance**, you can request assistance if there is a breakdown or a minor accident ⇒ *page 191*.

WARNING

In areas with poor GPS reception or outside the coverage range of the respective cell phone service provider, some functions and/or services may not be available, it may not be possible to send or receive data, or functionality may be limited.

Tips

To see which data can be transmitted, visit your Audi country or sales region website at www.audi.com.

Emergency call

Operation

Applies to: vehicles with emergency call function

The services are provided through a SIM card installed in the vehicle. Services are provided assuming that the mobile phone network required for the installed SIM card is functioning and available for use. The services made available by Audi are only available within the mobile phone net-

work coverage area for the mobile phone service provider selected by Audi.

Tips

- The emergency call function cannot be deactivated in the Infotainment system settings.
- The availability of the TPS emergency call is limited to certain times.
- The costs for call and data connections for TPS emergency calls is included in the price of the services.

Functions

Applies to: vehicles with emergency call function

A TPS emergency call can be made manually or automatically ⇒ *page 190*.

In the event that an automatic TPS emergency call is made, emergency responders as well as the local emergency call center or police station may receive the necessary information in order for help to arrive as quickly as possible.

Making an emergency call

Applies to: vehicles with emergency call function



Fig. 133 Front headliner: cover for the emergency call button

Manual emergency call

Requirement: the ignition must be switched on.

- ▶ Tap the cover **1** to open it.
- ▶ Press and hold the emergency call button until the LED **2** blinks. The emergency call will be made.
- ▶ If the emergency call button is pressed by mistake, then press it again immediately and hold ▶

it until the LED stays on. The emergency call will be canceled.

Automatic emergency call

The vehicle electrical system initiates an automatic emergency call under certain circumstances, for example if an airbag deploys. The LED in the emergency call button  will blink. The emergency call will be made. The emergency call cannot be canceled.

LED status

- **Green** – The emergency call function is available.
- **Red** – There is a malfunction in the emergency call function. Contact an authorized Audi dealer or authorized Audi Service Facility. Note the messages about the availability of the emergency function ⇒ *page 191*.
- **Off** – The emergency call function is not available, perhaps because no network is available.

Warnings

If there is a critical system failure in the emergency call systems, the vehicle occupants will receive the following warning: see ⇒ *page 191, LED status* and ⇒ *page 191, Messages*.

Tips

If the emergency call is canceled due to a poor connection, then the system automatically tries to connect again.

Messages

Applies to: vehicles with emergency call function

Emergency call function: malfunction! Limited availability. Contact Service

If this indicator light turns on and this message appears, the emergency call function is restricted. For example, you cannot call the emergency call center, but data may still be transmitted under certain circumstances. Drive to an authorized Audi dealer or authorized Audi Service Facility immediately to have the malfunction corrected.

Emergency call function: malfunction! Function unavail. Contact Service

If this indicator light turns on and this message appears, you cannot make an emergency call. Drive to an authorized Audi dealer or authorized Audi Service Facility immediately to have the malfunction corrected.

Online roadside assistance

Description



Applies to: vehicles with online roadside assistance

An online roadside assistance call ¹⁾ is a combination of data transmission and a phone call. The data transmission from your vehicle forwards important information to the Audi service center, such as the vehicle and position data.

Calling online roadside assistance

Applies to: vehicles with online roadside assistance

Calling online roadside assistance

- ▶ Press the  button. The LED in the button turns yellow. The online roadside assistance call will be made.
- ▶ If you press the  button by mistake, then press it again.

Audi incident assistance

A minor accident may be detected by the vehicle electrical system. You are able to select between online roadside assistance and an emergency call in the MMI.

Tips

If the roadside assistance call is canceled due to a poor connection, then the call must be made again.

¹⁾ The availability of the services offered depends on the country and may change in the future.

Navigation

Opening navigation

Applies to: vehicles with navigation system



Fig. 134 Route guidance not started

The navigation system directs you to your destination, around traffic incidents, and on alternative routes, if desired.

Opening navigation

► Applies to: MMI: Press **NAVIGATION** on the home screen.

After accessing the navigation for the first time, the map is displayed.

Opening navigation using the multifunction steering wheel

- Select the Navigation tab in the instrument cluster.
- To display navigation when route guidance has started, select in the instrument cluster: the  button > **Map**.

The following functions are available in the MMI:

- ① Select destination ⇒ *page 194, fig. 135*.
- ② Intelligent search ⇒ *page 193*.
- ③ **Switch between the map and the menu:** press  repeatedly until the desired function is displayed.

You can find additional information about the map update at ⇒ *page 198, Map operation*.

WARNING

- The demands of traffic require full attention of all road users. Always read the chapter ⇒ *page 20, Traffic safety information*.
- The route calculated by the navigation system is a driving recommendation. Follow the traffic regulations that are applicable in

the country where you are operating the vehicle. In the event that the driving directions contradict traffic regulations, always follow the traffic regulations applicable in the country where you are operating the vehicle to reduce the risk of an accident.

Note

Read the information about Audi connect, and be sure to note the connectivity costs section ⇒  in *General information on page 185*.

Tips

- Snow and objects on the GPS antenna or trees and large buildings can impair satellite reception and affect the system's ability to determine the vehicle position. Several deactivated or malfunctioning satellites can interrupt GPS reception.
- Because street names sometimes change, the names stored in the MMI may in rare cases differ from the actual street name.
- Applies to: multifunction steering wheel: Depending on the selected function, operation through the MMI may be required.
- Applies to: vehicles with Audi connect Infotainment: Depending on the country and vehicle equipment, additional services may be available.
- An additional indicator will appear in the head-up display*.

myAudi navigation

Applies to: vehicles with myAudi navigation

MMI navigation works seamlessly with the myAudi app.

Your destinations (favorites, last destinations) are synchronized through your myAudi account. All important destinations can be displayed in the vehicle and in the myAudi app.

To load destinations in the vehicle automatically, Audi recommends logging into the vehicle with a myAudi user ⇒ *page 31*.

myAudi navigation functions:

- You can send destinations and routes from the myAudi app to the vehicle ⇒ *page 195*.
- Active route guidance in the myAudi app can be continued in the MMI.
- Depending on the situation, it may be possible to continue active route guidance from the MMI in the myAudi app to continue navigating to the destination after leaving the vehicle.

Tips

- All services/apps can be modified, activated/deactivated, renamed, and enhanced without further notification.
- Depending on the country and model there may be an app other than the “myAudi app” available for your vehicle. For additional information, see my.audi.com.

Entering a destination

Intelligent search for navigation destinations

Applies to: vehicles with navigation system

Using the intelligent search, you can enter the data for a navigation destination in any order all at once (for example, 5th Avenue New York). Likewise, you can search for points of interest, contacts, previous destinations, or favorites in order to navigate to the desired destination.



Opening a menu

- ▶ Applies to: MMI: Select on the home screen: **NAVIGATION** > .

Intelligent search





- ▶ Enter one or more search terms into the input field ⇒ *page 24, Text input*.
- ▶ Press on the desired destination in the results list. The **Details** menu will be displayed.
- ▶ Press **Start**. Route guidance will be activated and the map will be displayed ⇒ *page 197, fig. 137*.

Online Points of Interest

- ▶ **Searching for points of interest:** enter the name of a POI.
- ▶ Select: *a symbol for a POI category (such as ) > a POI, or*
- ▶ To display all categories and search for a POI, select:  > *a category (such as restaurants) > a POI.*

Change search area

Requirement: route guidance must be active.







- ▶ Applies to: MMI: Select on the home screen: **NAVIGATION** > .
- ▶ To change the search area, press  /  /  repeatedly until the desired search area is selected.

Online search¹⁾

Applies to: vehicles with navigation system and online search

You can use the results from a search engine provider to find a navigation destination.

Requirement: the MMI must be connected to the Internet ⇒ *page 185, Audi connect*.

- ▶ Applies to: MMI: Select on the home screen: **NAVIGATION** >  > .
- ▶ Enter one or more search terms into the input field.
- ▶ The search engine provider shows suggestions  to narrow down the search.
- ▶ Press on suggestions, if available, until the desired destination appears in the results list. If necessary, use one finger to swipe upward or downward until the suggestions  or destinations  appear.
- ▶ Press on the desired destination . The **Details** menu will be displayed.
- ▶ Press **Start**.

Tips

- The MMI input suggestions depend on the last navigated destinations. ▶

¹⁾ Audi provides access to services from third party providers. Permanent availability cannot be guaranteed, because that depends on the third party provider.

- The navigation system always searches for the fastest route. You can have alternative routes displayed if necessary ⇒ *page 199*.
- If the destination cannot be found, it may not be stored in the navigation database. Check the spelling of the term that was searched or check the search area ⇒ *page 193*.
- Distances to points of interest are displayed as a straight-line distance from your current location. The actual distance from your current location to the point of interest is updated automatically. The list of points of interest that were found is not resorted when this happens.

Select destination

Applies to: vehicles with navigation system



Fig. 135 Menu: select destination

Opening a menu

- Applies to: MMI: Press **NAVIGATION** on the home screen.
- If the map is displayed, press ① ⇒ *page 192*, *fig. 134*.

The following functions are available:

① Last destinations	194
② Favorites	194
③ Contacts	194
④ Received destinations and routes .	195

Loading previous destinations

Applies to: vehicles with navigation system

Your last destinations and routes can be loaded as a navigation destination.

As soon as you start route guidance, the destination is automatically saved in the last destina-

tions. Your previous destinations are marked with the symbol.

If you use myAudi navigation, your previous destinations will be synchronized with your myAudi account ⇒ *page 192*.

Accessing previous destinations

- Applies to: MMI: Select on the home screen: **NAVIGATION** > > **Last destinations** > *select a destination* > **Start**.
- Select in the instrument cluster: Navigation tab > button > **Last destinations** > *a destination*.

Deleting previous destinations

- Applies to: MMI: Select on the home screen: **NAVIGATION** > > **Last destinations** > > *select one or more entries* or **Select all** > **Delete** > **(Done)**.

Tips

The last route will be automatically deleted from the list if you start a new route guidance after canceling the route.

Setting a favorite as the destination

Applies to: vehicles with navigation system

In the favorites, you can call up frequently-used destinations as well as your home/business address.

Requirement: a favorite must be stored ⇒ *page 200*.

- Applies to: MMI: Select on the home screen: **NAVIGATION** > > **Favorites** > *select a destination*.
- Select in the instrument cluster: Navigation tab > button > **Favorites** > *a destination*.

Selecting contacts as destinations

Applies to: vehicles with navigation system

You can navigate to contacts.

Requirement: a contact must have an address stored.

- ▶ Applies to: MMI: Select on the home screen: **NAVIGATION** > (☰) > **Contacts** > *a contact*.
- ▶ Press on the address for a contact.
- ▶ Press on a suggested address. The **Details** menu will be displayed.

i Tips

- If a contact is grayed out, there is no address stored for that contact.
- Navigation to geographical coordinates for a contact is not possible.

Loading received destinations and routes

Applies to: vehicles with myAudi navigation

You can search for destinations or routes in the myAudi app and send to the vehicle.

Requirement: the MMI and the mobile device must be connected to the Internet ⇒ *page 185, Audi connect*. You must have the myAudi app installed on your mobile device.

- ▶ Send a destination or route in the myAudi app to the vehicle.
- ▶ Applies to: MMI: Select on the home screen: **NAVIGATION** > (☰) > **Received destinations and routes**.
- ▶ Make sure you are logged into the vehicle and the myAudi app with the same myAudi account. The received destination and routes will be loaded automatically.
- ▶ **Navigating to a destination:** press on a destination.
- ▶ **Deleting destinations:** select: ✎ > *one or more entries* or **Select all** > **Delete** > **(Done)**.

i Tips

- All services/apps can be modified, activated/deactivated, renamed, and enhanced without further notification.
- Depending on the country and model there may be an app other than the “myAudi app” available for your vehicle. For additional information, see my.audi.com.

Destination details

Applies to: vehicles with navigation system



Fig. 136 Details

After you have selected a destination, the details will be displayed. Route guidance will not be active yet.

The functions depend on the vehicle equipment and the selected destination.

- 1 **Map preview:** to zoom in on the map preview, press on the map.
- 2 **Route criteria:** see ⇒ *page 204*.
- 3 **More:** additional functions.
- 4 **Weather:** Requirement: the MMI must be connected to the Internet ⇒ *page 185, Audi connect*. Also see ⇒ *page 187*.
- 5 **Call:** Requirement: a mobile device must be connected to the MMI ⇒ *page 174*. You will make a call to the phone number that is stored for the destination.
- 6 **Start:** starts navigation to the displayed destination. The map will be displayed ⇒ *page 198*.
- 7 **Parking:** press **Parking** to search for a parking space at the destination. You can use the parking space as a destination or stopover.
- 8 **Details:** Requirement: the MMI must be connected to the Internet ⇒ *page 185, Audi connect*.
- 9 **Display of distance/driving time to the destination**
- 10 **Weather at the destination:** Requirement: the MMI must be connected to the Internet ⇒ *page 185, Audi connect*.

Selecting a destination from the map

Applies to: vehicles with navigation system

A point on the map can be used as the destination.

Opening the map

- ▶ Applies to: MMI: Press **NAVIGATION** on the home screen.
- ▶ If necessary, press \triangle to display the map.

Adjusting the scale

- ▶ Select: \oplus/\ominus > *select a scale*.

Marking the destination

- ▶ Press and hold a point on the map until a marking appears or the address for the selected destination is shown.

Selecting map content (such as POIs) as the destination

Requirement: map content must be displayed
⇒ *page 203*.

- ▶ Press on map content on the map (for example, H).

Selecting the destination

- ▶ Select: P > **Start**.

Stopovers and route plan

Applies to: vehicles with navigation system

You can enter additional destinations during active route guidance.

Entering a stopover

Requirement: route guidance must be active.

- ▶ Enter a destination ⇒ *page 193*.

Displaying stopovers or the route plan

All destinations are listed in the route plan.

- ▶ Press on P in the side menu on the map
⇒ *page 197, fig. 137*.

Editing stopovers

- ▶ Press on P in the side menu on the map
⇒ *page 197, fig. 137*.

- ▶ **Adding a stopover:** Select: **Add destination** > *select a destination* > **Add to route**.
- ▶ **Moving a stopover:** press P . Touch the \blacklozenge symbol and move the entry to the desired position. Press **Done**.
- ▶ **Deleting a stopover:** Select: P > *one or more entries* or **Select all** > **Delete** > **(Done)**.

e-tron route planner

Applies to: vehicles with navigation system and e-tron route planner

The MMI includes the charging stations along the route, if the destination cannot be reached with the current battery charge level.

Requirement: the **e-tron route planner** must be switched on ⇒ *page 203*.

Entering a destination with the e-tron route planner

- ▶ Enter a destination.

If the destination is out of range, the fastest route with stopovers for charging will be suggested automatically.

- ▶ To start the suggested route guidance, press **Accept**.
- ▶ To display the route, press P , ⇒ *page 197, fig. 137* in the map side menu.

The destination is located outside of the range

The P symbol will be displayed if the destination in the current route plan cannot be reached.

- ▶ Press on P on the map. The route plan will be displayed.
- ▶ Press **e-tron route planner** to calculate an alternative route with suitable charging stations.

In the e-tron route planner, the following items will be shown for each destination: the calculated arrival time, the estimated battery charge level at arrival H and after charging H , the suggested charging duration H , and the distance from the current location. ▶



i Tips

- The calculated arrival time at the destination incorporates the suggested time for charging at the stopovers.
- The e-tron route planner continuously calculates the fastest route while taking into account the charging times at various charging stations. Therefore, a route with multiple charging stops could be faster than a route with fewer charging stops.

Stopping route guidance

Applies to: vehicles with navigation system

Requirement: route guidance must be active and the map must be displayed.

- ▶ Applies to: MMI: Press  ⇒ *page 197, fig. 137.*
- ▶ Select in the instrument cluster: Navigation tab >  button > **Cancel route guidance.**

Map

Map functions

Applies to: vehicles with navigation system



Fig. 137 Active route guidance



Fig. 138 Marked map object

Opening the map

- ▶ Applies to: MMI: Press **NAVIGATION** on the home screen.

- ▶ If necessary, press  to display the map.

The following list gives an overview of the information displayed on the map. Press on any function (for example, alternative routes) to show additional options.



- 1 Select destination ⇒ *page 194*
- 2 Entering a destination ⇒ *page 193*
- 3 Cancel route guidance ⇒ *page 197*
- 4 Current route
- 5 Request spoken prompt
- 6 Alternative routes ⇒ *page 199*
- 7 Display active destinations, stopovers, or route plan ⇒ *page 196*. The distance to the destination including the calculated arrival time is displayed
- 8 Online traffic information ⇒ *page 202*
- 9 Altitude
- 10 Displays the maximum permitted speed¹⁾: within city limits, on expressways, and on highways
- 11 Current vehicle position
- 12 Route information ⇒ *page 204*
- 13 Name of the street on which you are driving
- 14 Start route guidance for a marked destination ⇒ *page 196, Selecting a destination from the map*
- 15 Display details for the destination ⇒ *page 195*
- 16 Intelligent search nearby ⇒ *page 193*
- 17 Adjust the map orientation. See also ⇒ *page 203*
- 18 Settings ⇒ *page 203*
- 19 Adjust the scale. Press the magnifying glass to switch automatic zoom ⇒ *page 203* on the map on or off. The  symbol appears when this function is switched on
- 20 Marked destination ⇒ *page 196, Selecting a destination from the map*
- 21 Map contents (points of interest, favorites). When there are multiple map contents in the immediate vicinity, the symbols are shown stacked on the map. To display a list of

¹⁾ Applies to vehicles without camera-based traffic sign recognition.

individual symbols, press  ⇒ *fig. 138*. Press on a POI in the list

- 22 Center the map to the current vehicle position
- 23 Traffic incidents and display of estimated losses of time on the route
 - **Green:** traffic is flowing freely.
 - **Orange:** stop-and-go traffic
 - **Red:** traffic jam or traffic obstructions.

Additional possible symbols on the map

Symbol	Description
	Home address ⇒ <i>page 200, Favorites</i>
	Business address ⇒ <i>page 200, Favorites</i>
	Favorites ⇒ <i>page 200</i>
	Previous destinations display

Traffic information

- **Colored warning symbols:** traffic incidents ahead that are on your route.
- **Grayed out warning symbols:** traffic incidents that are not on your route.
- All traffic incidents will display in color when route guidance is inactive.
- **Warning symbols with arrow:** traffic incident that you have been routed around, for example .

Map operation

Applies to: vehicles with navigation system

You can operate the map ⇒ *page 197, fig. 137* with the movements described in the following information.

Moving the map

- ▶ Drag your finger across the map in the desired direction.

Moving the map quickly

- ▶ Swipe your finger across the map in the desired direction and lift your finger off the map.

Zooming in on the map

- ▶ Place two fingers on the map and pull your fingers apart, or
- ▶ Double-tap on the map with one finger.

Zooming out on the map

- ▶ Place two fingers on the map and pull your fingers together, or
- ▶ Double-tap on the map with two fingers.

Rotating the map

- ▶ Rotate the map using two fingers.

Tilting the map

- ▶ Drag upward or downward with two fingers.

Tips

Certain gestures may not be available on all touch displays or in every menu.

Navigation view with route guidance started

Applies to: vehicles with navigation system and Audi virtual cockpit

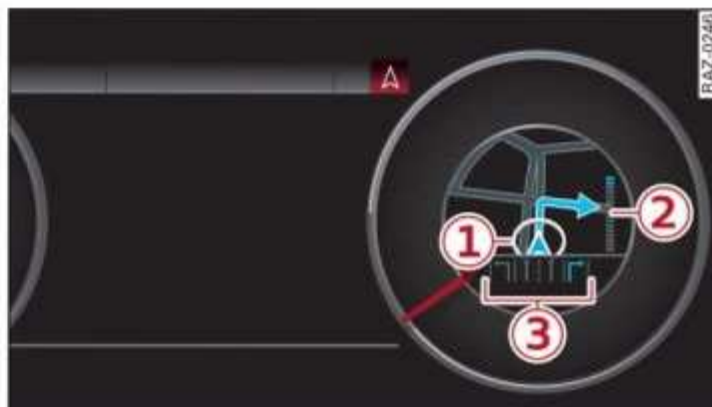

Fig. 139 Instrument cluster: default view: turning maneuver when route guidance has started

Requirement: route guidance must be on ⇒ *page 193*.

The following information will be displayed in the driver information system, if available:

- 1 Current vehicle position
- 2 A bar graph appears when there is an upcoming turn. The fewer the bars that are shown, the shorter the distance is until the turn. If there is no upcoming turn immediately ahead, the distance to the destination or stopover, the calculated arrival time, and a ▶

direction arrow for the upcoming maneuver will be displayed in the right speedometer. If there is no upcoming maneuver, the distance to the next maneuver will be displayed.

- ③ Lane recommendation

Predictive route guidance

Applies to: vehicles with navigation system and predictive route guidance

Your MMI can learn the routes that you drive frequently (such as your daily commute to work and back) and suggest route guidance based on the current vehicle position.

When the function is switched on, the MMI records the routes driven regardless of whether or not you are using navigation.

Without starting route guidance, your MMI can check the traffic conditions and show possible traffic incidents for the possible routes to be driven.

Opening personal routes

Requirement: predictive route guidance is switched on ⇒ [page 204](#). Route guidance must not be active. A notification is displayed.

- ▶ The MMI displays up to three suggestions. Press on a suggestion. Route guidance will start.

Better routes

If there are major traffic incidents, the MMI will display a notification regardless of the selected menu. If the MMI has calculated a better route, you can select it as the route.

- ▶ Press on the notification.

As soon as you switch off predictive route guidance, your personal routes will no longer be recorded. Routes that were already stored will remain stored.

Deleting personal routes

- ▶ Applies to: MMI: Select on the home screen: **NAVIGATION** >  > **Predictive route guidance**

- > **Delete recordings from the last 24 hours** or **Delete all personal routes and destinations.**

Tips

If the predictive route guidance is switched off and you press , the predictive route guidance settings will be displayed ⇒ [page 204](#).

Alternative routes

Applies to: vehicles with navigation system



Fig. 140 Alternative routes in the overview map

Opening alternative routes

Requirement: route guidance must be started ⇒ [page 193](#) and the map must be displayed ⇒ [page 198](#).

- ▶ Press on  in the side menu on the map ⇒ [page 197](#), [fig. 137](#).

① Current route

The distance to the destination and the calculated arrival time will be displayed for the current route.

② Alternative route

The difference in travel time compared to the selected route will be displayed.

Displaying alternative routes in the foreground

- ▶ Press ① in the corresponding information window, or
- ▶ Press and hold the information window for the corresponding alternative route (for example, ② ⇒ [fig. 140](#)).

Select route

- ▶ Press on the information window for the corresponding route (for example ②).

Additional functions

Favorites

Applies to: vehicles with navigation system

In the favorites, you can call up frequently-used destinations as well as your home/business address.

Accessing favorites

- ▶ Applies to: MMI: Select on the home screen: **NAVIGATION** > (☰) > **Favorites**.

If you use myAudi navigation, your favorites will be synchronized with your myAudi account
⇒ page 192.

Storing favorites

- ▶ Press ☆ in the **Details** menu ⇒ page 195, fig. 136.

Storing a home address or business address

- ▶ Press **Home address** or **Business address**.
When accessed for the first time, you will be prompted to set the address.
- ▶ Select: **Create now** > *enter a destination* > **OK**.

Editing a home address or business address

Requirement: the favorites list must be displayed. Your home address or business address must be stored.

- ▶ Press **Home address** or **Business address** until the **Options** menu is displayed.
- ▶ Select: **Change address** > *enter a destination* > (**Set as destination**) or (*Add to address*) > **OK**.

Editing favorites

Requirement: the favorites list must be displayed.

- ▶ **Setting a favorite as a destination:** press on a favorite.
- ▶ **Deleting favorites:** in the **Details** menu, press ★ ⇒ page 195, fig. 136, or select: ✎ > *one or more entries* or **Select all** > **Delete** > (**Done**).
- ▶ **Moving a favorite:** press ✎. Touch the ⬆ symbol and move the entry to the desired position. Press **Done**.

i Tips

- After deleting the home address or business address, only the address is deleted and the entry will still be displayed in the favorites.
- Please note when moving favorites that items 1 and 2 are reserved for the home address and business address.

On-street parking

Applies to: vehicles with navigation system and on-street parking

In supported areas, you can display parking along the route.

Requirement: the **Parking** notification must be switched on ⇒ page 23, *Notification center*. The MMI must be connected to the Internet ⇒ page 185, *Audi connect*. Route guidance must be active, you must be close to your destination, and a notification must be displayed or an item on the map must be marked.

- ▶ Press on the notification, or
- ▶ Press ☐ on the map.
- ▶ To navigate to a parking: space, press on a colored marking on the map.
- ▶ Select: ☒ > **Start**.

Depending on availability, colored markings on the map indicate the probability of open parking spaces.

Color	Description
Green	High probability
Orange	Medium probability
Red	Low probability

Satellite map

Applies to: vehicles with navigation system and satellite map

You can display the navigation map with satellite images.

Requirement: the MMI must be connected to the Internet ⇒ page 185, *Audi connect*. ▶

- Applies to: MMI: Select on the home screen: **NAVIGATION** >  > **Map settings** > **Satellite map**¹⁾.

The map view is based on data packets received from the Internet in the form of satellite images, which are then combined with the roadways from the  *page 197, fig. 137* standard map view.

Tips

- The satellite map¹⁾ is updated regularly whenever the function is opened. The process may take several seconds.
- Depending on the Internet connection, the standard map may also be displayed when the satellite map is switched on¹⁾.

Electric range

Applies to: vehicles with electric range display



Fig. 141 Electric range display

The electric range shows the distance that can be driven using electric power. Information such as the type of road, speeds, and altitude will be taken into account.

- Applies to: MMI: Select on the home screen: **NAVIGATION** >  > **Map settings** > **Range map**.



- ① Depending on environmental conditions, the start of the colored section shows the probable minimum electric range for your vehicle.
- ② The border indicates the maximum electric range for your vehicle under optimal conditions.

Map update

Introduction

Applies to: vehicles with navigation system

You can update the map data in the MMI with a map update. The functions depend on the country and vehicle equipment.

- Map update through **online map update**  *page 201*.
- Import a map update from the **USB connection** to your MMI  *page 202*.

Online map update

Applies to: vehicles with online map update

Using the online map update, you can update the map content for your navigation system in your vehicle.

The MMI determines regions based on the vehicle position. Based on this, update data for these regions are available for your MMI.



Starting the update

Requirement: the MMI must be connected to the Internet  *page 185, Audi connect*.

- Applies to: MMI: To allow automatic map updates, select on the home screen: **SETTINGS** > **System maintenance** > **Automatic online map update**. The MMI starts the map update automatically in the background when new map material is available.

You can check the status of the download process and the installation in the notification center  *page 23*.

Note

Read the information about Audi connect, and be sure to note the connectivity costs section   in *General information on page 185*.

¹⁾ Audi provides access to services from third party providers. Permanent availability cannot be guaranteed, because that depends on the third party provider.

i Tips

Because of the high volume of data, Audi recommends performing the map update using the USB connection ⇒ *page 202*.

Map update using the USB connection

Applies to: vehicle with map updates using the USB connection

With the map update, you can update the map material in your navigation system.

Requirement: you must have created a myAudi account at my.audi.com. Your vehicle must be registered in your myAudi account.

Downloading updates

- ▶ Download the map update at my.audi.com and store it on a USB flash drive. For additional information, visit my.audi.com.

Installing updates

- ▶ Connect the USB flash drive to the USB port with charging function ⇒ *page 213*.
- ▶ Open the notification in the notification center on ⇒ *page 23* and press on the notification.
- ▶ Press **Next**. The status of the installation is shown in the display.

Traffic information

Introduction

Applies to: vehicles with navigation system and online traffic information



Fig. 142 Traffic information overview

Open traffic information

Requirement: the map must be displayed ⇒ *page 198*.

- ▶ Press on the traffic jam symbol in the side menu on the map ⇒ *page 197, fig. 137*.

Display traffic report details

- ▶ Press on the traffic report ②.
- ▶ To display the previous or next traffic report, press ← or →.

The following information can be displayed:

- ① A message will appear if the MMI calculates a better route for the current route guidance. The predicted delay takes into account future changes to the traffic situation on the route. Press on an item in a list ① and select the better route. More information can be found under ⇒ *page 199*.
- ② A traffic message is displayed. The distance to the hazardous area is calculated from the current vehicle position.
- ③ The traffic messages are only shown when route guidance is active. Press on a line to display details about it.

i Tips

- Particularly critical traffic information, such as warnings about wrong-way drivers, is automatically displayed as a notification.
- Traffic information is not available in some countries.

Traffic rerouting

Applies to: vehicles with navigation system

By receiving traffic information, your MMI calculates a better route if available and the possible time saved compared to the current route.

Traffic rerouting

- ▶ Start route guidance.

The MMI uses a notification or a note in the traffic information ① ⇒ *page 202, fig. 142* to indicate a better route. You can decide which route you would like to use.

To select a better route, you have the following options:

- ▶ **Notification:** press . The better route will be used for route guidance, or press on the notification. Press on the information window for the better route (for example ② ⇒ *page 199, fig. 140*).

- ▶ **Note in the traffic information:** press on the list entry ① ⇒ page 202, fig. 142. Press on the information window for the better route (for example ② ⇒ page 199, fig. 140).

Online traffic information

Applies to: vehicles with navigation system and online traffic information.

The MMI can receive real-time online traffic information about congestion, accidents, road construction, and other incidents.

Requirement: the MMI must be connected to the Internet ⇒ page 185, *Audi connect*. Traffic information must be switched on in the MMI ⇒ page 203.

Traffic information will be displayed on the standard map ⇒ page 197, fig. 137.

Depending on vehicle equipment, online traffic information may also be displayed on the satellite map ⇒ page 200.

Tips

- Having the **online traffic information** function switched on provides the most accurate reports of traffic situations and traffic forecasting. Your vehicle transmits and processes its anonymous, encrypted position information at regular intervals to the traffic data provider. You can switch off data transfer at any time ⇒ page 283.
- The **online traffic information** network is not available in all countries, and the coverage is not nationwide.

Settings

Applies to: vehicles with navigation system

You can adjust the navigation system settings in the instrument cluster and in the MMI display separately. The settings depend on the country and vehicle equipment.

Accessing settings

- ▶ Applies to: MMI: Select on the home screen: **NAVIGATION** > .

Accessing settings using the multifunction steering wheel

- ▶ Select in the instrument cluster: Navigation tab >  button.

A setting made using the multifunction steering wheel only applies to the instrument cluster map.

Map settings

Satellite map: see ⇒ page 200.

Traffic info: you can display current traffic information on the map.

- **Free flowing traffic**
- **Traffic obstructions**
- **Traffic incidents**

Map colors

- **Automatic:** the map display adapts to the lighting conditions (for example, by changing from day to night when driving through a tunnel).
- **Day or Night**

Map orientation

- **2D heading up/2D north up:** the current vehicle position is displayed. The map is oriented in the direction of travel or to the north.
- **3D map:** the current vehicle position is shown on a three-dimensional map and is aligned to the direction of travel.
- **Overview:** the entire route from the vehicle position to the destination or the next stopover is displayed on the map. The map is oriented to the north.

Automatic zoom

- **On:** the map scale is adapted automatically depending on the type of road being traveled (expressway, highway, other roads) so that you always have an optimal overview of the road ahead. When route guidance is active, the scale is adjusted automatically for a better detailed view when there are upcoming maneuvers.
- **Intersection:** when route guidance is active, the scale is adjusted automatically for a better detailed view when there are upcoming maneuvers.
- **Off**

MMI map contents/Map content: you can switch the display of additional information (such as POIs) on the map in the center display on or off.

Voice guidance

Voice guidance: with the **Traffic info** setting, the MMI will only give prompts if there are traffic incidents on your route.

Voice guidance during phone call

Entertainment fader during navigation: the audio playback volume is temporarily lowered when navigation prompts are active.

Route criteria

You can adjust which route criteria should be allowed or avoided for the route calculation.

HOV/carpool lanes

Highways

Toll roads

Ferries

e-tron route planner

This function can be switched on and off.

Prefer Electrify America charger station

When this function is switched on, the e-tron route planner will give preference to Electrify America charging stations.

Route information

When this function is switched on and route guidance is active, route information [⇒ page 197, fig. 137](#) is displayed. The next maneuver will be displayed at the bottom. POIs and traffic information will also be displayed. Press route information to display a preview of the next maneuver on the map. You can switch the following information on or off in route information.

- **Points of interest along the route**
- **Traffic information along the route**

Predictive route guidance

The predictive route guidance is switched off when the vehicle is delivered from the factory.

Your trips are recorded and destinations are suggested by the MMI when this function is switched on [⇒ page 199](#).

Presentation mode

In presentation mode, the system simulates driving on the display along the planned route without the vehicle actually moving. You can use **Specify starting point** when you would like to calculate a route starting from a location other than the current vehicle position, for example. **Simulating route guidance:** start route guidance and press presentation mode.

Tips

You can change the volume of navigation announcements while one is playing [⇒ page 30](#).

Radio

General information

Selecting the radio



Fig. 143 Center display: FM station list



Fig. 144 Center display: SiriusXM station list

Depending on the vehicle equipment, the radio may support the FM and SiriusXM (satellite radio) frequency bands. Using the HD Radio receiver* also allows you to receive radio stations on the FM bands in digital format.

Depending on the vehicle equipment and the selected station list, the following information will be displayed:

① Station list

Shows the stations that are currently available. The station list updates automatically.

② Stations

For example, the station name may be displayed depending on availability.

③ HD Radio technology

FM stations that can be received by digital radio are marked with the HD Radio technology symbol **HD**.

If reception quality declines, the radio will automatically switch to the analog FM station depending on availability.

④ Additional audio programs

Digital HD Radio stations may contain multiple additional audio programs. If you lose reception, the additional audio programs will

be muted since they can no longer be received.

⑤ Radio ID

Your radio ID and contact data for your satellite radio provider are displayed.

⑥ Channel number

⑦ No reception

The station cannot be received.

In addition to the symbols for the usual frequency bands, the following information may also be available depending on vehicle equipment:

Symbol	Description
	The station provides information in the background for an online station alternative. Online station tracking must be switched on for this ⇒ <i>page 211</i> .
	The station is received through the Internet.
	The system attempts to receive the station/podcast through the Internet.

i Tips



- Contact the SiriusXM* provider if you would like to receive satellite programming.
- Buildings, tunnels, bridges, open areas, other vehicles or objects on the vehicle roof can affect reception.
- Satellite radio* is not available in all regions.

Adjusting the radio using the MMI

- ▶ Applies to: MMI: To set a frequency band, select on the home screen: **RADIO > Source a category**.
- ▶ Applies to: MMI: To set a station, select on the home screen: **RADIO > Source > a category > a station/podcast***.
- ▶ To select a frequency, follow the instructions under ⇒ *page 207, Free text search*.

Adjusting the radio using the multifunction steering wheel

Requirement: radio mode must be on. ▶

- ▶ Select the radio/media tab in the instrument cluster.
- ▶ Press the  button to toggle between the radio and media or to select a different source.
- ▶ Press the  button to select a channel or source, or
- ▶ To control using gestures, swipe your finger up or down in area  ⇒ page 14, fig. 5.

▶ To confirm a channel or source, press .

i Tips

Applies to: multifunction steering wheel: Depending on the selected function, operation through the MMI may be required.

Radio functions

Overview















Fig. 145 Center display: left side: playback view of radio functions, right side: sources

Operating

- ▶ Applies to: MMI: To open the playback view , select on the home screen: **RADIO > Source > a category > a station/podcast***.
- ▶ Applies to: MMI: To open the sources , select on the home screen: **RADIO > Source**.

The following functions may be available depending on the selected radio station/podcast* and the vehicle equipment:

Symbol/Description	Description
 	Displaying categories in a frequency band.
 Source	Displays sources in the Radio menu.
 Frequency band	Shows the current station frequency band.
 ON	Indicates that on demand content is playing. The MMI must be connected to the Internet for this.
 	Presets ⇒ page 208
 	Settings ⇒ page 210.
 Station logo	Depending on availability, you can switch between the image views: press on the station logo. Use one finger to swipe to the right or left to switch between the Station logo and Cover art (album cover). Also see ⇒ page 211, Online additional data .
 	Go back one level.

	Symbol/Description	Description
11	Search	See ⇨ page 207.
12	Last stations	See ⇨ page 208.
13	Presets	See ⇨ page 208.
14	FM	Displays stations from the FM frequency band.
15	Online	See ⇨ page 209.
16	SiriusXM	Displays stations from the SiriusXM frequency band. Combines SiriusXM Live channels and on demand content, depending on vehicle equipment.
17	Start Over	Go to the beginning of the broadcast.
	Related	Channels, artists, and shows related to the content that is currently playing.
	Subscribe	Log in to be able to play the content.
	Switch to WEB	Switch manually to Internet reception.
	Switch to SAT	Switch manually to satellite reception.
18	More	Access options for the current station ⇨ page 210.
19	⏮/⏭	Selecting the previous or next track: press ⏮ or ⏭. Going to the beginning of the recording: press and hold ⏮. Going to the live program: press and hold ⏭. The LIVE symbol will be displayed.
20	⏪/⏩	Select the previous/next station.
21	▶/⏸	Start or stop playback
	🔊/🔇	Unmutes or mutes playback.
22	List	The station list is displayed ⇨ page 205.
23	Info section	Depending on availability, the station name as well as program information, for example, may be displayed. Also see ⇨ page 211, Online additional data.

! Note

Read the information about Audi connect, and be sure to note the connectivity costs section ⇨ ! in *General information on page 185.*

i Tips

Not all functions are available in every source and on every touch display.

Free text search

Using intelligent search, you can search for station names, frequencies, program types (such as **News**), podcasts*, or online radio stations*.

Opening free text search

► Applies to: MMI: Select on the home screen: **RADIO > Source > Search.**

Entering search terms

You can enter multiple search terms at once in any order.

The following information may be available:

Symbol	Description
🕒	Results from the list: Last stations
☆	Results from the list: Presets
📻	Results from a Station list
For example, FM	Station frequency band

Last stations

You can listen to the last stations that were played in all frequency bands.

Accessing last stations

- ▶ Applies to: MMI: Select on the home screen: **RADIO > Source > Last stations.**

Listening to last stations

- ▶ Press on a station.

Deleting last stations

- ▶ Select:  > *select one or more stations* or **Select all > Delete > (Done).**

Presets



You can store your favorite stations from every frequency band in the presets list.

Applies to: SiriusXM: Channels, shows, and sports teams will be stored in the presets as Smart Favorites. After switching the ignition and the MMI on, the Smart Favorites store radio programs at a specific time.

Selecting presets using the MMI

- ▶ Applies to: MMI: Select on the home screen: **RADIO > Source > Presets > a preset.**

Storing presets

- ▶ Press on   in the playback view
⇒ *page 206, fig. 145.*



Requirement: a list with radio stations must be displayed ⇒ *page 205, fig. 143.*

- ▶ Press and hold an entry in the list until the **Options** menu appears.
- ▶ Press **Store as preset.**

Editing presets

- ▶ **Deleting presets:** press  in the playback view, or
- ▶ In the presets list, select:  > *one or more stations* or **Select all > Delete > (Done).**

Requirement: the presets list must be displayed.

- ▶ **Moving a preset:** press .
- ▶ Touch the  symbol and move the entry to the desired position.

- ▶ Press **Done.**

Live Sports

Applies to: vehicles with SiriusXM



Using the Live Sports category, you can find live commentary about your favorite teams during a live sports broadcast. Depending on vehicle equipment, you may be able to switch commentary that favors a certain side on or off.

Accessing live games

- ▶ Applies to: MMI: Select on the home screen: **RADIO > Source > SiriusXM >  > Sports > Live Sports > a game.**



The score, the status of the game, and, if available, the current possession of the ball are displayed.

Saving/deleting a favorite team

- ▶ Press /.

Switching commentary on or off

Requirement: the MMI must be connected to the Internet.

- ▶ Press /.

Radio text

Program information (for example, general text messages, artist, composer, song) is displayed in the radio text.

Requirement: the selected radio station must support the radio text function.

Opening radio text

- ▶ Applies to: MMI: Select on the home screen: **RADIO > select a frequency band (such as FM) > select a station > More > Radio text.**

Depending on vehicle equipment, the following functions may be available:

Displaying previous radio text entries

- ▶ Swipe downward with one finger. The last radio text entries are displayed if they are available. ▶

Scrolling through radio text entries

- ▶ Swipe upward or downward with one finger.

Showing Radio Text Plus information

If a radio text entry is displayed with a color, a phone number or a navigation destination for the station is available as radio text plus information.

You have the following options:

Selecting the destination

- ▶ Select: *a navigation destination marked in color* > **Set as destination**.

Call

- ▶ Select: *a phone number marked in color* > **Call**.

Tips

A call to a phone number stored in the radio text will start immediately.

Online radio

General information

Applies to: vehicles with Audi connect Infotainment and online radio

You can listen to various radio stations or podcasts on the Internet using online radio.

Requirement: the MMI must be connected to the Internet. A data plan must be available
⇒ *page 188*.

Accessing online radio through the MMI

- ▶ Applies to: MMI: Select on the home screen: **RADIO > Source > Online**.

The following functions are available:

Previous selection

The station/podcast list for the last station or podcast that was playing will be displayed.

Top stations

The favorite online radio stations are displayed.

Filter list

- ▶ Select:  > *(a category)* > *a station/podcast*.

Note

Read the information about Audi connect, and be sure to note the connectivity costs section
⇒  in *General information on page 185*.

Tips

- Depending on the Internet connection and network traffic, the connection may be lost when online radio is playing.
- Online radio reception may not be possible if Internet service is throttled.
- Online media usage depends on the service availability of the third party provider.
- The range and screen display of online media services from third party providers in the vehicle can vary.
- Please note that it may not be possible to play some online radio stations in certain countries.
- Audi only provides access to online radio and does not assume any responsibility for the content of these services.

Podcasts

Applies to: vehicles with Audi connect Infotainment and online radio

Opening podcasts using the MMI

- ▶ Applies to: MMI: Select on the home screen: **RADIO > Source > Online > Podcasts**.

The following functions are available:

Listening to a podcast

- ▶ Select: *a podcast* > *a podcast episode*.

Search

- ▶ Press .

The following functions are available in the podcast playback view:

Displaying podcast episodes

- ▶ Press **List**.

Starting/stopping podcast playback

- ▶ Press **▷ / ||**.

Previous/next podcast

- ▶ Press **K** / **D**.

Changing the playback position

- ▶ Move the slider into the desired position.

Displaying the online radio menu

- ▶ Press **☰**.

Switching to radio

- ▶ Press **Source**. The sources in the Radio menu are displayed.

Podcast favorites

You can store podcasts in the podcast favorites.

Requirement: the playback view for a podcast must be displayed.

- ▶ Press **☆** **7** ⇒ page 206, fig. 145.

Requirement: a list with podcasts must be displayed.

- ▶ Press and hold an entry in the list until the **Options** menu appears.
- ▶ Press **Save podcast**.

Listening to podcast favorites

Requirement: the podcast favorites list must be displayed. At least one podcast favorite must be stored.

- ▶ Select: *a podcast* > *a podcast episode*.

Browsing through podcast favorites

Requirement: the podcast favorites list must be displayed. At least one podcast favorite must be stored.

- ▶ Press **<** or **>**.

Displaying all podcast favorites

Requirement: the podcast favorites list must be displayed. At least one podcast favorite must be stored.

- ▶ Press **All**.

Editing podcast favorites

- ▶ **Deleting podcast favorites:** press **★** in the playback view, or

- ▶ In the podcast favorites list, select: **All** > **✎** > *one or more podcasts*, or **Select All** > **Delete** > **(Done)**.

Requirement: the podcast favorites list must be displayed.

- ▶ **Moving podcast favorites:** Select: **All** > **✎**.
- ▶ Touch the **◆** symbol and move the entry to the desired position.
- ▶ Press **Done**.

Options and settings

Options

Requirement: the playback view **1** ⇒ page 206, fig. 145 must be displayed.

- ▶ Press **More** **18**, or

Requirement: a list with radio stations or podcasts* must be displayed ⇒ page 205, fig. 143.

- ▶ Press and hold an entry in the list until the **Options** menu appears.

Depending on the selected source and vehicle equipment, the following functions may be available.

- **Store as favorite** ⇒ page 208.
- **Radio text** ⇒ page 208.
- **Save podcast** ⇒ page 210, **Podcast favorites**.

Related content

Channels, artists, and shows related to the content that is currently playing.

Settings

- ▶ Applies to: MMI: Select on the home screen: **RADIO** > **⚙**.

Depending on the vehicle equipment, the following settings may be available:

FM HD Radio

You can switch HD Radio reception on or off.

SiriusXM Tune Start

If you play a Smart Favorite or Internet radio station when this function is switched on, the song ▶

currently playing on the channel will play from the beginning.

SiriusXM subscription status

The status of your license is displayed.

Call SiriusXM: the telephone number and radio ID of your satellite radio provider are displayed. To call your satellite radio provider using the MMI, press **Call SiriusXM**.

Online additional data



Requirement: the MMI must be connected to the Internet. A data plan must be available
⇒ *page 188*.

When the function is switched on, additional information (such as album cover, artist, track) will be loaded depending on the availability.

Online station tracking

Requirement: the MMI must be connected to the Internet. A data plan must be available
⇒ *page 188*. A station provides information in the background for its online station alternative and is identified with the  symbol.

During reception loss in the FM frequency band, the radio tuner can establish a data connection and switch to an online station alternative, if it is

available. If available, you can receive your local radio stations in every region of your country online. This may result in additional costs ⇒ . The  symbol indicates a station that is currently being received online.

- **Automatic/Off:** activates or deactivates automatic switching to online station alternatives.
- **With request:** switching to online station alternatives must be confirmed manually.

Preferred online radio data rate

Depending on the selected radio station, you may be able to adjust the data rate for Internet radio ⇒ *page 209* and for the **Online station tracking**.

For optimal sound playback, press **High**. To reduce data usage, press **Low**.

Note

Read the information about Audi connect, and be sure to note the connectivity costs section ⇒  in *General information on page 185*.

Tips

Delays may occur when switching automatically between normal frequency bands and online radio.

Troubleshooting

The information that follows lists some troubleshooting options. They depend on the equipment.

Problem	Solution
A station is no longer displayed in the station list.	Store the station as a preset in advance. Access the presets using the presets list ⇒ <i>page 208</i> .
Online radio: no playback from online radio.	Check if a data plan has been purchased for the applicable country and it is available ⇒ <i>page 188</i> .

Media

General information

There may be different media sources and connections available depending on the vehicle equipment. For example, you can play media files using a connected USB drive or connect your mobile devices to the USB ports with charging function and operate them through the MMI.

Media and format restrictions: the MMI (including the USB storage device connection) was tested with a variety of products and media on the market. However, there may be cases where individual devices/media and media files may not be recognized, may play only with restrictions, or may not play at all.

Restricted functionality: reset the MMI to the factory default settings if functionality is restricted ⇒ *page 226*.

Digital Rights Management: please note that the media files are subject to copyright protection.

Files that are protected by DRM and are identified with the symbol  will not play.

Data security: never store important information on mobile devices. Audi is not responsible for damaged or lost files and media.

Loading times: the more files/folders/playlists there are on a storage medium, the longer it will take to load. To reduce the amount of time it takes the media files to load, use a storage medium that only contains media files, and create subfolders (for example, for each artist or album).

Additional information: when playing, audio files are automatically displayed with any additional information that is stored (such as the artist, track and album cover). If this information is not available on the medium, the MMI will revert to the local Gracenote metadata database or search online if necessary. See ⇒ *page 218*, **Online additional data**. However, in some cases, the additional information may not be displayed.

Note

Read the information about Audi connect, and be sure to note the connectivity costs section ⇒  in *General information on page 185*.

Bluetooth audio player

Applies to: vehicles with Bluetooth audio player

With the Bluetooth audio player, you can play music wirelessly through the MMI from your Bluetooth-capable mobile device (such as a cell phone).

Requirement: the vehicle must be stationary. The Bluetooth settings will open on your mobile device during the connection setup. The Bluetooth function and visibility of the MMI ⇒ *page 225* and mobile device must be switched on.

Connecting a mobile device

- ▶ Applies to: MMI: Select on the home screen: **MEDIA > Source > Connect external device > New connection**. The available Bluetooth devices will be displayed after several seconds.
- ▶ Press on the desired mobile device in the list of displayed Bluetooth devices.
- ▶ To update the list, press .

A PIN for a secure Bluetooth connection will be generated.

- ▶ Confirm the PIN on your mobile device.

After connecting successfully, the mobile device will be displayed in the **Connected devices** menu as a Bluetooth audio player.

Playing media ⇒ *page 214*.

Tips

- Check for any connection requests on your Bluetooth device.
- Multiple Bluetooth audio players can be paired with the MMI, but only one at a time can be active as a Bluetooth audio player ⇒ *page 227*.
- The supported media functions (such as shuffle, list view, categories, search, options) depend on the Bluetooth device being used.

- Note the volume setting on your Bluetooth device. Audi recommends setting your mobile device to the maximum volume when using it as a Bluetooth audio player.
- A selection of supported Bluetooth devices can be found in the database for tested mobile devices at www.audi.com/bluetooth.

Amazon Alexa

Applies to: vehicles with Amazon Alexa Integration

You can play various Amazon Alexa content using the MMI. The voice recognition system is used to operate it.

Requirement: Amazon Alexa must be activated
⇒ *page 28*. A data plan must be available
⇒ *page 188*.

- ▶ Start Amazon Alexa using the voice recognition system.
- ▶ Applies to: MMI: Select on the home screen: **MEDIA > Source > Alexa**.

WARNING

Always follow the information found in ⇒  in *General information on page 185*.

Note

Read the information about Audi connect, and be sure to note the connectivity costs section
⇒ *page 185*.

Multimedia connections

USB adapter

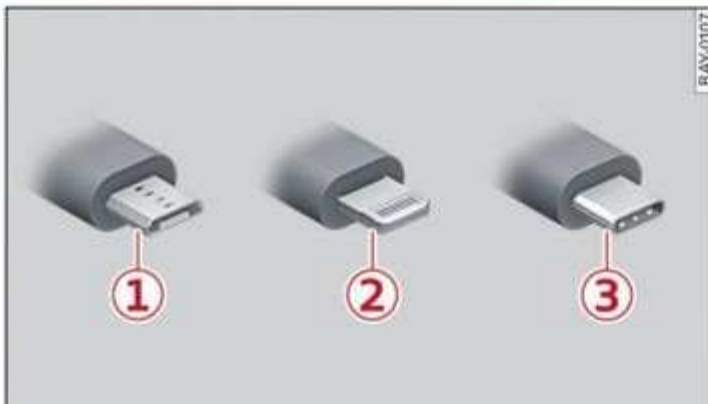

Fig. 146 Audi Genuine Accessories: USB adapter

You can connect your mobile devices to the MMI using the USB ports with charging function with a

USB adapter, and charge the battery at the same time.

You can purchase the USB adapter cable from an authorized Audi dealer or at specialty stores:

- ① USB adapter for devices with a micro USB connection
- ② USB adapter for Apple devices with a Lightning connection
- ③ USB adapter for devices with USB type C connection

Note

Handle the USB adapter carefully. Do not allow it to be pinched.

Tips

Apple devices with a dock connector can only be charged using a USB adapter designed for devices with a dock connector. Data cannot be transmitted.

USB ports with charging function

Connect your mobile devices to the USB ports in order to operate the devices through the MMI and charge the batteries.

The USB ports are located in the front center console and are labeled with the  symbol. If multiple USB devices are connected to the USB ports (for example, a smartphone and a USB flash drive), any of these devices can be used as the playback source.

Connecting or charging mobile devices using a USB adapter

- ▶ Connect the matching USB adapter to a USB port and to the mobile device, such as a smartphone.

The battery will charge automatically.

Mobile devices connected to the USB ports are started and operated using the MMI ⇒ *page 214*.

Disconnecting a mobile device from the USB port

- ▶ Remove the USB adapter cable from the USB port.

! WARNING

Driving requires your complete and undivided attention. As the driver of the vehicle, you have complete responsibility for safety in traffic. Never operate mobile devices while driving, because this increases the risk of an accident.

! Note

- Disconnect the connector from the USB port carefully to reduce the risk of damaging them.
- Use a USB extension cable to connect devices that have an integrated USB connector (such as a USB stick) to reduce the risk of damage to your USB device and the USB port.
- Extremely high or low temperatures that can occur inside vehicles can damage mobile devices and/or impair their performance. Never leave mobile devices in the vehicle in extremely high or low temperatures.

i Tips

- Always follow the information found in ⇒ *page 79*.
- When you switch the ignition off, the USB ports will still be supplied with power until the energy management system switches them off.
- Do not use additional adapter cables or USB extension cables to connect mobile devices to USB ports that already have a cable or that must be connected with a USB adapter cable (⇒ *page 213, fig. 146*). Using an additional adapter or USB extension cable may impair functionality.
- Functionality is not guaranteed for mobile devices that do not conform to the USB 2.0 specification.
- USB hubs are not supported.
- Video playback through the USB ports is not supported on Apple devices and MTP devices (such as smartphones).
- iPod touch or iPhone malfunctions also affect the operation of the MMI. Reset your mobile device in these situations.

- Audi recommends updating the iPod touch or iPhone software to the latest version. Refer to your mobile device owner's manual for more information.
- USB adapters on the USB ports will support iPod touch or iPhone devices from the 5th generation or newer with a lightning connector.
- A selection of supported devices can be found in the database for tested mobile devices at www.audi.com/mp3.

Playing media

Media sources

The following sources can be selected depending on the vehicle equipment:

- **Alexa** ⇒ *page 213*.
- **USB device** ⇒ *page 213*.
- **Connect external device:** you can connect external devices via Bluetooth and use the Bluetooth audio player ⇒ *page 212*, or you can connect an external device directly to the USB port with charging function ⇒ *page 213*.



Accessing media

Playing media files using the MMI

- ▶ Applies to: MMI: Select on the home screen: **MEDIA > Source > a source**. Depending on the connected device, the symbol for a source may change. The device name may be displayed (for example: myPhone).
- ▶ Select a track from the categories in the media center ⇒ *page 215*.

Playing media files using the multifunction steering wheel

Requirement: a media source must contain media files ⇒ *page 214*.

- ▶ Select the radio/media tab in the instrument cluster.
- ▶ Press the  button to toggle between the radio and media or to select a different source.
- ▶ Press the  button to select a media file or source, or

- ▶ To control using gestures, swipe your finger up or down in area ⑦ ⇒ page 14, fig. 5.
- ▶ To confirm a media file or source, press **OK**.

i Tips

- For safety reasons, the video image is only displayed when the vehicle is stationary. Only the sound from the video plays while driving.
- Applies to: multifunction steering wheel: Depending on the selected function, operation through the MMI may be required.

Media center

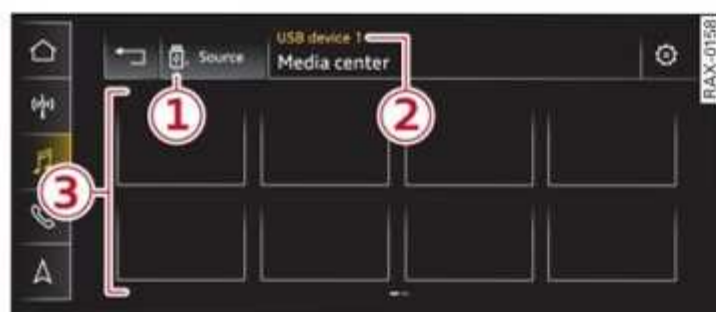

Fig. 147 Center display: media center

There are various categories available in the media center. You can also search for media files across sources. The current music track continues playing while you search the MMI.

Opening the media center

- ▶ Applies to: MMI: Select on the home screen: **MEDIA > Source > a source > a category.**

① Source symbol

The symbol for the source that is currently in use is displayed. Depending on the connected device, the symbol for the source may change. As an example, a USB stick is shown connected to the USB port with charging function.

② Source device name

The device name of the source that is currently in use is displayed.

③ Categories

The media center will display categories depending on vehicle equipment, the connected device,

the content of the selected source, and the connection type:

- Last played tracks
- Artists
- Compilations
- Composers
- iTunes Radio
- Audio books
- Podcasts
- Genres
- Videos
- Tracks
- Albums

Playlists

All playlists and smart playlists in the source are displayed.

Smart playlists

- Last played tracks
- Most played tracks

Folders

The folder structure or track/chapter list is displayed.

! Note

Applies to: vehicles with Audi connect Infotainment

- Cloud services and the iTunes radio category always require an Internet connection.
- Read the information about Audi connect, and be sure to note the connectivity costs section ⇒ **i** in *General information on page 185.*

i Tips

- Only the categories supported by the medium are available.
- For safety reasons, the video image is only displayed when the vehicle is stationary. Only the sound from the video plays while driving.
- When synchronizing a mobile device with Cloud services, playlists may display incorrectly in the MMI. Use the media center in the device.

– Applies to: iPod touch/iPhone: Note the information about the USB port with charging

function and the supported devices
⇒ page 213.

Media functions

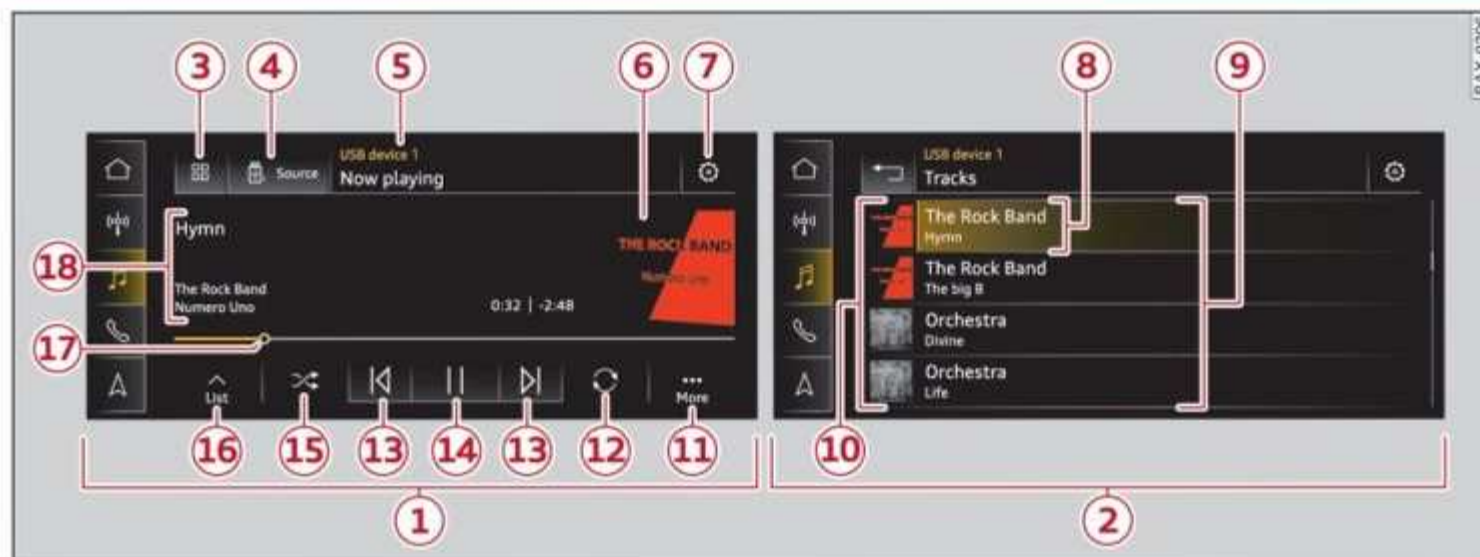

Fig. 148 Center display: left side: playback view; right side: playlist

Operating

► Applies to: MMI: To open the playback view (1), select on the home screen: **MEDIA** > **Source** > *a source* > *a category* (for example, **Artists** > *Album*) > *a track*.

► To open the playlist (2), select **List** in the playback view (16).

The following functions may be available depending on the selected media source and the vehicle equipment:

	Symbol/Description	Description
(3)		The media center categories are displayed based on the active source ⇒ page 215.
(4)	Source	Displays sources in the Media menu.
(5)	Source/device name	device name of the source that is currently playing.
(6)	Album cover in the playback view	Requirement: a media source with album covers must be selected or the covers must be available online ⇒ page 218, Online additional data . Displays the current album cover. Display the playlist: press on the cover.
(7)		Settings ⇒ page 218.
(8)	Current track information	Display of Track and Artist . Highlights the track that is currently playing.
(9)	List	Browsing in the list: drag your finger upward or downward.
(10)	Album cover in the playlist	Requirement: a media source with album covers must be selected or the covers must be available online ⇒ page 218, Online additional data . Displays the current album cover.
(11)	More	Opens options ⇒ page 217.

	Symbol/Description	Description
12	Off	Switching between off/playlist/track: press 12.
	Playlist	The tracks in the current playlist will repeat continuously in a loop.
	Track	The current track will repeat continuously in a loop.
13		Selecting the previous/next track (or station/chapter): press K or DI.
		Fast forward/rewind: to fast forward or rewind within a track, press and hold DI or K. Jumping to the beginning of a track: press on K after the first three seconds of play time.
14		Start or stop playback
15		When this function is switched on, all files in the playlist will play in random order.
16	List	The playlist 2 is displayed.
17	Playback position	The bar shows the current playback position in the track. Fast-forward or rewind: to fast forward or rewind within a track, move the bar to the right or left.
		Changing the playback position: press the desired playback position.
18	Info section	Display of Track, Artist, and Album.

Tips

Not all functions are available in every source and on every touch display.

Free text search

Applies to: vehicles with free text search

You can search across all active sources, for example for tracks and artists.

Opening the search

Requirement: the selected source must support the search function.

► Applies to: MMI: Select on the home screen: **MEDIA > Search**.

Entries that contain the entered search term are listed in the results list. Each result is marked with the symbol for a category in the media center ⇒ page 215.

You can search for the following categories:

- Artists
- Albums
- Tracks
- Genres

– Videos

Options and settings

Options

Context-dependent functions and settings may be available depending on vehicle equipment, the selected source, the connected mobile device, and the connection type.

Requirement: the playback view must be displayed 1 ⇒ page 216, fig. 148.

► Press **More** 11.

Play more like this

The track currently playing is quickly analyzed for features such as artist, genre, mood, and beat, and a smart playlist with similar tracks will be shown.

Aspect ratio

Audi recommends the **Auto** setting for the picture format. If you press on an aspect ratio, you will see a preview of the setting on the screen. Press **OK** to apply the selected aspect ratio. ►

The following table gives an overview of the aspect ratios. The possible aspect ratios depend on the source or video file being played.

Aspect ratio	Description
Auto	The MMI detects the picture format of the source and displays the image in the optimal ratio.
4:3, 16:9	The image is fixed in the corresponding ratio. Select one of these options if the image is distorted or a section of the image is cut off or blurry when Auto is selected.
Zoom	The image is enlarged to fill the entire display.
Original	The image is displayed in the ratio of the source format. Select this option if the image is distorted or a section of the image is cut off or blurry when Auto is selected.

Settings

Accessing settings

- Applies to: MMI: Select on the home screen: **MEDIA** > .

Depending on the vehicle equipment, the following settings may be available:

Online additional data

Requirement: the MMI must be connected to the Internet. A data plan must be available
⇒ *page 188*.

When the function is switched on, additional information (such as album cover, artist, track) will be loaded depending on the availability.

Supported media and file formats

Overview

Depending on the vehicle equipment, media files with the following properties may be supported by the connection for USB storage devices:

Audio/video files	
Supported media	USB ports with charging function: mobile devices ⇒ <i>page 213</i> such as iPhones, MTP players, and USB storage devices in "USB Device Sub-class 1 and 6" that conform to USB 2.0: USB sticks, USB MP3 players (Plug-and-Play capable), external USB flash drives, and hard drives
File system	USB storage devices: exFAT, FAT, FAT32, NTFS. USB storage device partitions (primary/logical*): 2 per USB connection.
Metadata	Album cover: GIF, JPG, PNG with max. 800x800 px. The album cover from the medium or from Gracenote* is displayed, depending on availability.
Playlists	.M3U; .PLS; .WPL; .M3U8; .ASX
Number of files	USB mass storage device: max. 50,000 files per medium; max. 1,000 files per playlist/folder

Audio files		
Format	File extension	
MPEG 1/2 Layer 3	.mp3	Up to maximum 320 kbit/s 48 kHz sampling frequencies
Windows Media Audio 9/10	.wma	
MPEG 2/4	.m4a; .m4b; .aac	
Opus	.opus; .ogg; .oga	
FLAC	.flac	48 kHz sampling frequency
ALAC	.m4a	
Monkey's Audio	.ape	

Video files		
Format	File extension	
MPEG 1/2	.mpg; .mpeg	up to maximum 15 Mbit/s and 1920x1080 px at maximum 30 fps
MPEG4 AVC (H.264)	.mp4; .m4v; .mov; .avi	
Windows Media Video 9	.wmv; .asf	
MPEG-H (H.265/HEVC)	.mp4; .mov	
VP8/VP9	.webm	
Flash video	.flv; .f4v	

Tips

- The media sources do not support the Windows Media Audio 9 Voice format.
- For compressing MP3 files, Audi recommends a bit rate of at least 160 kbit/s. The display showing the remaining play time may differ for audio files with variable bit rate.
- Special characters (such as those in ID3 tag information) may display differently or may

not always display, depending on the system language.

- The manufacturer of the storage device can provide information about its "USB Device Subclass".
- Some MTP player functions are not supported, such as rating music tracks and video playback.

Troubleshooting

The information that follows lists some troubleshooting options. They depend on the equipment.

Problem	Solution
USB ports with charging function/Bluetooth® audio player: the mobile device is not supported.	Read the instructions in the chapter ⇒ <i>page 213, Multimedia connections</i> /⇒ <i>page 212, Bluetooth audio player</i> .
USB ports with charging function: the mobile device is not recognized as a source.	For many mobile phones or mobile devices, playback is not possible when the battery level is too low (less than 5% charge level). The mobile device will only be recognized as a media source in the MMI after connecting if the battery charge level is sufficient. ▶

Problem	Solution
USB ports with charging function: malfunctions during audio playback through an iPod touch/iPhone.	The Bluetooth® audio player function is switched on. Switch this function off ⇒ <i>page 225</i> when you are not using the Bluetooth® audio player .
USB ports with charging function: audio playback through the connected mobile device is not possible.	Make sure the USB mode <i>MTP</i> is selected in the settings on your mobile device.
Bluetooth® audio player: interference with track display and audio playback.	Playback interference can occur when using the Bluetooth® audio player if a music player app from a third party provider is open. Audi recommends using the integrated media player on your Bluetooth device (such as a smartphone).

Interactive experience

Themes¹⁾

Applies to: vehicles with themes

This function offers the option to customize the Infotainment system, for example by changing the background image.

Selecting a theme will change the appearance of the Infotainment system and the interior lighting if applicable.

Downloading themes

Requirements: You must have the myAudi app installed on your mobile device. You added your vehicle to the myAudi app. You are logged into the vehicle with your myAudi user.

- ▶ Open the myAudi app and download the desired theme.

Managing themes

Requirement: you have already downloaded a theme.

- ▶ Choose your desired theme in the myAudi app, or
- ▶ Applies to: MMI: To activate a theme, select on the home screen: **THEMES** > *a theme*.
- ▶ Applies to: MMI: To go back to the default appearance, select on the home screen: **SETTINGS** > **Display & Brightness** > **MMI** > **Themes** > **Deactivate**.

Using as a screensaver

The screensaver will display the background image without showing the menu icons.

Requirement: you have already activated a theme.

- ▶ Applies to: MMI: Swipe to the right until the background image is displayed without menu icons.

¹⁾ The function or equipment that is described was in development at the time this manual was published and may not be available in your vehicle.

Smartphone interface

Setup

Applies to: vehicles with smartphone interface

You can connect your smartphone to the MMI with a cable or wirelessly* using the smartphone interface. Certain content on your smartphone is adapted in the MMI while driving and can be operated through the MMI.

Connecting smartphones with a cable

Requirement: the vehicle must be stationary. An iPhone from the 6th generation or newer with lightning connection must have the latest operating system installed or a smartphone with Android Auto app must have Android 5.0 Lollipop or newer installed.

- ▶ Connect your smartphone to the USB port with charging function ⇨ *page 213* using a USB adapter ⇨ *page 213, fig. 146*.

Connecting smartphones wirelessly

Applies to: vehicles with wireless Apple CarPlay/wireless Android Auto

Requirement: the vehicle must be stationary. An iPhone from the 6th generation or newer with lightning connection must have the latest operating system installed or a smartphone with Android Auto app must have Android 11 or newer installed.

- ▶ To connect your smartphone wirelessly, switch on the Bluetooth function and Wi-Fi on your smartphone.
- ▶ Applies to: Apple CarPlay: Open the Apple CarPlay settings in your iPhone.
- ▶ Applies to: Android Auto: Make sure that wireless Android Auto is allowed in the app settings in your smartphone.
- ▶ Enable the Bluetooth function and visibility on the MMI ⇨ *page 225*.
- ▶ Applies to: MMI: Select on the home screen: **SETTINGS > Connected devices > Smartphone interface > New connection**.
- ▶ In the MMI, press on your smartphone in the list of displayed devices.
- ▶ To update the list, press ↻.

Establishing a wired/wireless* connection

- ▶ Follow the system instructions if necessary.
- ▶ Pay attention to any additional system prompts on your smartphone, if applicable.
- ▶ Applies to: MMI: If you declined use of Apple CarPlay or Android Auto the first time you connected your smartphone, then select on the home screen: **SETTINGS > Connected devices > Smartphone interface > a smartphone**.
- ▶ Follow the system instructions.



WARNING

Driving requires your complete and undivided attention. As the driver of the vehicle, you have complete responsibility for safety in traffic. Never operate mobile devices while driving, because this increases the risk of an accident.



Note

Read the information about Audi connect, and be sure to note the connectivity costs section ⇨ *page 185*.



Tips

- The functions that can be used depend on the following factors, among others:
 - The brand of your smartphone
 - The version of the operating system in your smartphone
 - The software version of the app used
 - The USB adapter cable and correct connection
 - Your cell phone service provider
 - The customized settings on your smartphone
- One of the factors above or a combination of any of them could cause incompatibility with the smartphone interface. Compatibility cannot be guaranteed for all types of smartphones. For more information and assistance, refer to the user guide and the manufacturer of your smartphone.
- Please note that in order to use the smartphone interface, you can only connect your smartphone via the front USB port with charging function.

- Wireless Apple CarPlay*/wireless Android Auto* is not available in all countries.
 - Wireless Apple CarPlay*/wireless Android Auto* is only possible in vehicles without a navigation system or without a detected vehicle position (GPS data) if the following requirement is met: the embedded SIM card for the vehicle must be logged into the mobile phone network ⇒ *page 186*.
 - If the connected smartphone has voice control, you can operate your smartphone using the external voice recognition system ⇒ *page 28*.
 - The MMI uses the menu language selected in your smartphone settings.
- Some MMI functions are not available when there is an active smartphone interface connection.
 - You cannot connect any mobile devices via Bluetooth when a smartphone interface connection is active.
 - Usage of the smartphone interface depends on the availability of services through third party providers.
 - Audi merely provides access to third party services through the MMI and does not assume any responsibility for the content of these services.

Troubleshooting

Applies to: vehicles with smartphone interface

The information that follows lists some troubleshooting options. They depend on the equipment.

Problem	Solution
Smartphone interface cannot be opened.	Check the battery charge level on your smartphone. Check the USB adapter and use a different one if necessary. Check if Android Auto or Apple CarPlay is available in the country where the vehicle is being operated.
	Android Auto: check if the Android Auto app is installed on your smartphone.
Connecting the smartphone to the MMI failed.	Make sure that you are using the correct USB adapter and check if the USB adapter is connected correctly to your smartphone and the USB port with charging function ⇒ <i>page 213</i> .
	Apple CarPlay: check if Apple CarPlay is activated on your iPhone.
	Android Auto: check in the Android Auto app if Android Auto permits new vehicles.

Problem	Solution
Wireless connection between the smartphone and the MMI failed.	Apple CarPlay: open the settings for Bluetooth and Apple CarPlay on your iPhone. Remove your vehicle.
	Android Auto: open the settings for Bluetooth on your smartphone. Remove your vehicle. Also remove your vehicle in the Android Auto app.
	Open the Connected devices menu ⇒ <i>page 227</i> . Delete your smartphone in the Telephone 1 and smartphone interface menu items. Repeat the connection process. Restart the MMI ⇒ <i>page 20</i> . Restart your smartphone. Open the Wi-Fi settings in your smartphone. Check if your smartphone has connected to the 5 GHz vehicle Wi-Fi. Try connecting to the 5 GHz Wi-Fi manually.
The smartphone is not automatically detected.	Make sure that you are using the correct USB adapter and check if the USB adapter is connected correctly to your smartphone and the USB port with charging function ⇒ <i>page 213</i> . Check if the requirements needed to connect a smartphone have been met.

Additional settings

System settings

Introduction

General settings are described in this chapter. You can find specific settings in the chapters about those settings. The available settings depend on the vehicle equipment.

Date and time

- Applies to: MMI: Select on the home screen: **SETTINGS > General > Date & time.**

Possible settings:

- Automatically set date and time
- Date
- Time
- Date format
- Time format
- Automatic time zone
- Time zone

Measurement units

- Applies to: MMI: Select on the home screen: **SETTINGS > General > Measurement units.**

Possible settings:

- Speed
- Distance
- Temperature
- Volume
- Pressure
- Consumption (electric motor)

Language and keyboard

- Applies to MMI: Select on the home screen: **SETTINGS > Language & Keyboard.**

Language

You can change the languages for the display, navigation announcements, and the voice recognition system.

Keyboard

See ⇨ page 24.

Sound

Requirement: an audio source must be active.

- Applies to MMI: Select on the home screen: **SETTINGS > Sound.**

Possible settings:

- Treble
- Bass
- Balance/fader
- Speed dependent volume control
- Subwoofer
- Surround Level
- Focus
- Panorama

Announcements and tones

- Applies to: MMI: Select on the home screen: **SETTINGS > Announcements & Tones.**

Possible settings:

- Announcement volume



WARNING

Adjust the volume of the audio system so that signals from outside the vehicle, such as police and fire sirens, can be heard easily at all times.



Tips

The volume is automatically adjusted to a pre-set level when the MMI is switched on.

Bluetooth

- Applies to MMI: Select on the home screen: **SETTINGS > Connection settings > Bluetooth®**

Bluetooth

You can select a setting for visibility of the MMI to other Bluetooth devices. To connect a new Bluetooth device, the **Visible** setting must be

selected. If **Invisible** is selected, a Bluetooth connection will only be possible with paired devices. If **Off** is selected, no Bluetooth device can be connected.

Bluetooth® audio player

When this function is switched on, the profile will load automatically when your Bluetooth audio player is within range.

Bluetooth® name

The MMI's Bluetooth name is displayed and can be changed.

Tips

The *name of the Wi-Fi hotspot* and the *Bluetooth name* are automatically compared when there are changes.

Factory default settings

- ▶ Applies to MMI: Select on the home screen: **SETTINGS > System maintenance > Restore factory settings.**
- ▶ Follow the system instructions.

The settings will be reset. The system will restart. This may take some time.

Tips

Make sure that not only the settings were deleted but also the stored data, if applicable.

Software update

Introduction

Applies to: vehicles with software update

You can update your vehicle's software.

The functions depend on the country and vehicle equipment:

- Update through the online system update ¹⁾
⇒ *page 226.*
- Map material update for the navigation system
⇒ *page 201.*

¹⁾ The function or equipment that is described was in development at the time this manual was published and may not be available in your vehicle.

- Have the software update performed by an authorized Audi dealer or authorized Audi Service Facility. This can result in additional costs.

WARNING

- Perform the installation only when the vehicle is stationary. Otherwise, this increases the risk of an accident
- If the installation fails, contact an authorized Audi dealer or authorized Audi Service Facility immediately to have the malfunction corrected.

Online system update¹⁾

Applies to: vehicles with online system update

With the online system update, you can update the software directly in the vehicle.

Requirement: the MMI must be connected to the Internet ⇒ *page 185, Audi connect.* you must be logged in to your myAudi account in the vehicle.

Downloading updates

Online system updates are downloaded automatically and without prior notice, and will resume if necessary once the ignition is turned on again. A message will be displayed in the center screen after the download is complete.

Installing updates

Requirement: an online system update must be downloaded and a notification must be shown in the center display.

- ▶ Stop the vehicle safely.
- ▶ Switch the emergency flashers off, if necessary
- ▶ Make sure that the 12 volt vehicle battery is charged.
- ▶ Make sure that the high-voltage battery is not being charged and that no charging connector is connected to the charging port.
- ▶ Press on the notification, or
- ▶ Open the notification in the notification center on ⇒ *page 23* and press on the notification.
- ▶ Follow the system instructions. ▶

- ▶ To start the update, exit and lock the vehicle.

The MMI will start the installation. When the update has ended, a notification will be displayed.

WARNING

To ensure the installation is completed successfully, the ignition must not be switched on during the installation.

Note

Read the information about Audi connect, and be sure to note the section about connectivity costs ⇨  in *General information on page 185*.

Connected devices

Displayed connected devices

Requirement: the vehicle must be stationary.

- ▶ Applies to: MMI: Select on the home screen: **SETTINGS > Connected devices**.

Possible menu items:

- Telephone 1
- Telephone 2
- Audio player
- Wi-Fi hotspot
- Headset

Smartphone interface

You can connect your smartphone to the MMI ⇨ *page 222*.

myAudi app

This function is available if an appropriate Audi app is installed on your mobile device and started, and if the mobile device is connected to the vehicle's Wi-Fi hotspot.

Note

Read the information about Audi connect, and be sure to note the connectivity costs section ⇨ *page 185*.

Managing connected devices

Requirement: the connected devices menu must be displayed ⇨ *page 227*.

Connecting a device

Requirement: Bluetooth visibility must be activated in the MMI ⇨ *page 225* and mobile device.

- ▶ Press on a menu item, such as **Telephone 1**.
- ▶ To search for and connect your mobile device, press **New connection** ⇨ *page 174*.

Selecting a connected device

- ▶ Press on a menu item, such as **Telephone 1**.
- ▶ Press on the desired mobile device in the list of displayed devices. The connection will be made.

Disconnecting a connected device

- ▶ Press on a menu item, such as **Telephone 1**.
- ▶ Press on the connected mobile device. The selected mobile device will be disconnected from the MMI.

Deleting a device

- ▶ Press on a menu item, such as **Telephone 1**.
- ▶ Press and hold an element until the **Options** menu is displayed.
- ▶ Press **Delete**.

If a device is listed multiple times, it will be deleted from all menu items.

Additional options

Depending on the selected function, additional options may be available.

Requirement: the connected devices menu must be displayed ⇨ *page 227*.

- ▶ Press on a menu item, such as **Telephone 1**.
- ▶ Press and hold an element until the **Options** menu is displayed.

Bluetooth® profiles

You can switch desired profiles on or off separately in the MMI. ▶

Favorite

To set a paired mobile device as the default phone, activate this function in the MMI.

When the mobile device is in range and the Bluetooth function on the mobile device and in the MMI is switched on, the default phone will be given priority over the other Bluetooth devices and will be connected directly to the MMI.

Legal information

General information

Information on the software licenses can be found online at www.audi.com/softwareinfo.

Multi Media Interface

- ▶ Applies to: MMI: Select on the home screen: **SETTINGS > General**.

Licenses

Version information

Legal notes

Possible options:

- **Software information**
- **About Audi connect**

Smartphone interface

Applies to: vehicles with smartphone interface

Requirement: a smartphone must be connected to the MMI ⇨ *page 222*.

- ▶ Applies to: MMI: Select on the home screen: **SETTINGS > Connected devices > Smartphone interface**.
- ▶ Press and hold an element until the **Options** menu is displayed.
- ▶ Press **Legal notes**.

Instrument cluster

Requirement: the vehicle must be stationary and the ignition must be switched on.

- ▶ Select in the instrument cluster: vehicle functions tab ⇨ *page 14*.

- ▶ Press and hold the  button on the multifunction steering wheel until the display appears.

Possible options:

- **Engine code**
- **Software information**
- **Version information**

Head-up display

Applies to: vehicles with head-up display

Requirement: the vehicle must be stationary and the head-up display is switched on.

- ▶ Applies to: MMI: Select on the home screen: **SETTINGS > Display & Brightness > Head-up display > Display contents > Show the license text in the head-up display**.









Checking and Filling Front compartment

General information

Special care is required if you are working in the front compartment

For work in the front compartment, such as checking and filling fluids, there is a risk of injury, scalding, accidents, and burns. For this reason, follow all the warnings and general safety precautions provided in the following information. The front compartment of the vehicle is a potentially dangerous area. ⇨ ⚠.

Explanation of warning symbols:

	Observe all warnings - there is a risk for injury!
	Hot components! Rotating parts!
	Hot surfaces. The surfaces of individual components may become hot due to the heat generated during operation. Do not touch components - there is a risk of burns!
	
	The radiator fan can switch on at any time!
	High voltage! The voltage in the high-voltage system is high enough to cause fatal injuries. Touching a damaged high-voltage component can result in a fatal electric shock.
	
	Hot coolant - there is a risk of scalding!
	Always follow the instructions in the operating manual.

⚠ WARNING

- Switch the ignition off.
- Set the parking brake.
- Keep children away from the front compartment.
- Never spill operating fluids in the front compartment.
- Avoid short circuits in the electrical system.

- Never reach into the radiator fan. The fan is temperature-controlled and can turn on suddenly, even when the ignition is switched off.
- Never open the hood when there is steam or coolant escaping from the front compartment, because there is a risk that you could be burned. Wait until no steam or coolant is escaping.
- The cap on the coolant expansion tank must never be opened when the coolant is hot. The cooling system is under pressure.
- To protect your face, hands, and arms from hot steam or coolant, cover the cap with a thick cloth when opening.
- All work on the battery or electrical system in your vehicle can result in injuries, chemical burns, accidents, or burns. Because of this, all work must be performed **only** by an authorized Audi dealer or authorized Audi Service Facility.
- Limit your exposure to chemicals to as short a time as possible.

⚠ WARNING

- The voltage in the high-voltage system is high enough to cause fatal injuries. Touching a damaged high-voltage component can result in a fatal electric shock. The components in the high-voltage system are marked with a warning label which warns of the high-voltage.
- The voltage level in the high-voltage system is still dangerous and potentially life-threatening when the ignition is switched off.
 - Never perform work on orange high-voltage cables or on high-voltage components. Only authorized repair facilities that are certified may perform work on the high-voltage system.

⚠ WARNING

- California Proposition 65 Warning:
- Engine exhaust, some of its constituents, and certain vehicle components contain or emit chemicals known to the State of California to cause cancer and birth defects and

reproductive harm. In addition, certain fluids contained in vehicles and certain products of component wear contain or emit chemicals known to the State of California to cause cancer and birth defects or other reproductive harm.

- Battery posts, terminals and related accessories contain lead and lead compounds, chemicals known to the State of California to cause cancer and reproductive harms. Wash hands after handling.

Note

When filling fluids, be sure not to add any fluids to the wrong reservoirs. Otherwise, severe malfunctions and damage will occur.

For the sake of the environment

You should regularly check the ground under your vehicle in order to detect leaks quickly. If there are visible spots from operating fluids, bring your vehicle to an authorized Audi dealer or authorized Audi Service Facility to be checked.

Opening and closing the hood

The hood is released from inside the vehicle.



Fig. 149 ① Footwell: release lever; ② front compartment: lever to open the hood

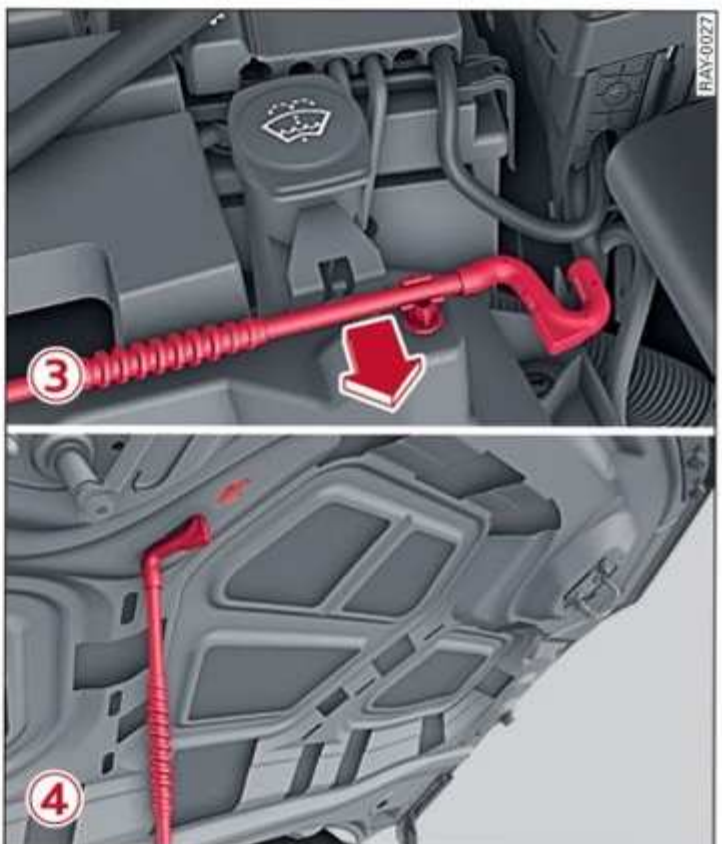



Fig. 150 ③ Front compartment: hood support in the re-
tainer; ④ the hood support is inserted in the hood

Observe the safety precautions ⇒ page 229, *General information*.

Make sure the wiper arms are not raised up from the windshield. Otherwise the paint could be damaged.

Opening the hood

- ▶ With the door open, pull the lever ① ¹⁾ below the instrument panel in the direction of the arrow.
- ▶ Lift the hood slightly ⇒ .
- ▶ Press the lever under the hood ② in the direction of the arrow. This releases the hooks.
- ▶ Open the hood.
- ▶ Pull the hood support out of its retainer ③ and insert it into the hood ④.

Closing the hood

- ▶ Lift the hood slightly.
- ▶ Remove the hood support from the opening ④ and press it into the retainer ③.

Messages

The following messages may appear depending on the vehicle equipment:

Warning! Hood is not locked. Stop vehicle and check the lock

The hood latch is not locked correctly. Stop immediately and close the hood.

WARNING

- Never open the hood when there is steam or coolant escaping from the front compartment, because there is a risk that you could be burned. Wait until no steam or coolant is escaping.
- For safety reasons, the hood must always be latched securely while driving. Because of this, always check the hood after closing it to make sure it is latched correctly. If the front corners of the hood cannot be lifted, then the lid is latched correctly.
- If you notice that the hood is not latched while you are driving, stop immediately and close it, because driving when the hood is not latched increases the risk of an accident.

¹⁾ The  symbol is not available in all countries.

Front compartment overview

The most important check points.

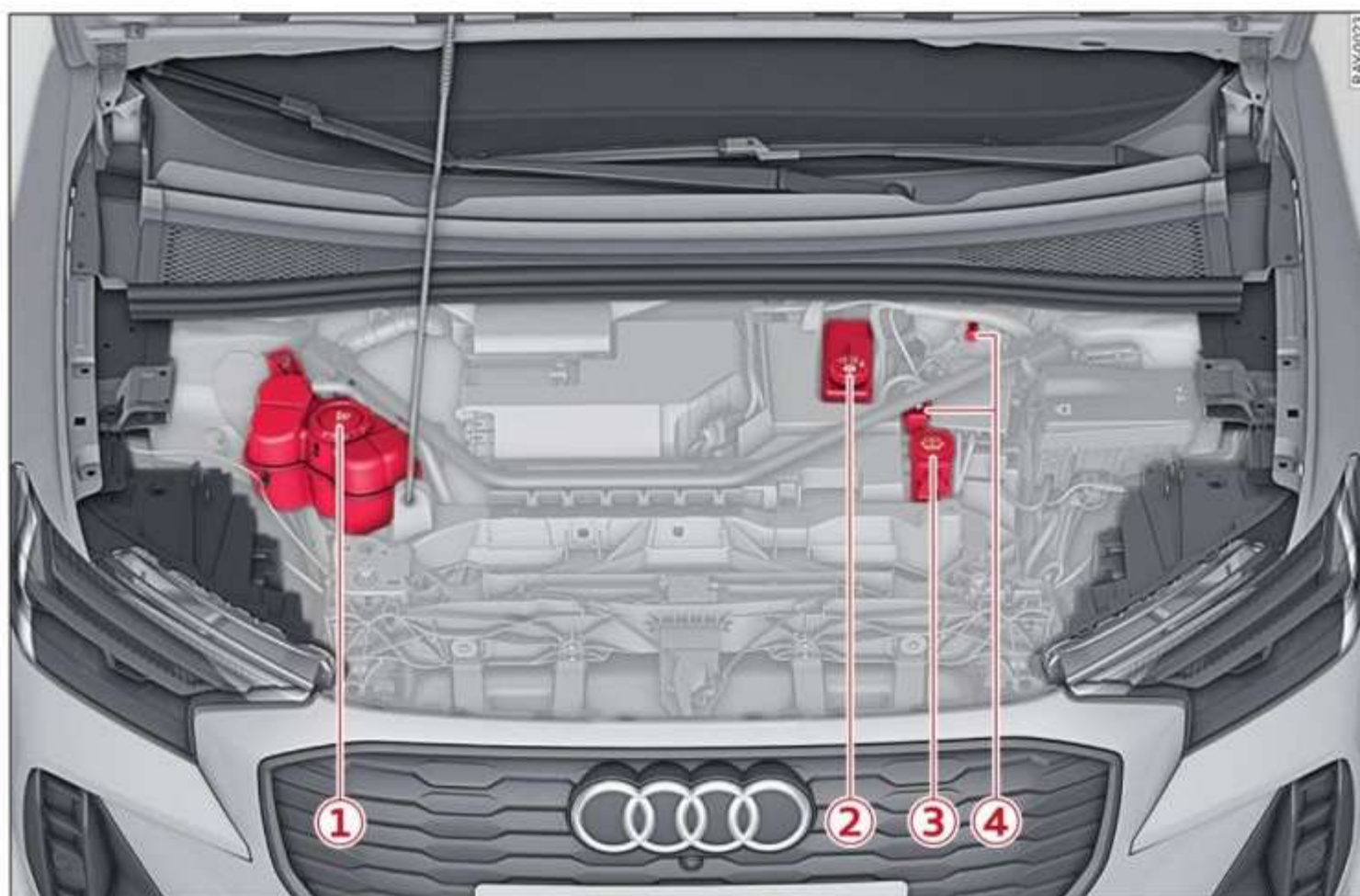

Fig. 151 Overview: diagram

Observe the safety precautions ⇒ page 229, *General information*.

- ① Coolant expansion tank (☹) ⇒ page 233
- ② Brake fluid reservoir (⊖) ⇒ page 234
- ③ Washer fluid reservoir (☹) ⇒ page 239
- ④ Charge points: (+) under a cover, (-) with hex head screw ⇒ page 238, *Charging the 12 volt vehicle battery*, ⇒ page 272, *Jump starting*

Cooling system

Coolant

The cooling system is filled with a mixture of purified water and coolant additive at the factory. This coolant must not be changed.

The coolant level is monitored using the  indicator light. However, you should occasionally check the coolant level.

Messages

The following messages may appear depending on the vehicle equipment:

 **Turn off engine and check coolant level. See owner's manual**

The coolant level is too low.

Do not continue driving and switch the ignition off. Check the coolant level ⇒ page 233.

 **Electric drive: overheated! Safely stop vehicle and check coolant**

Do not continue driving and switch the ignition off. See an authorized Audi dealer or authorized Audi Service Facility for assistance.

Coolant additive

The coolant additive is made of anti-freezing and corrosion protection agents. Only add the following coolant additives mixed with distilled water. ►

Coolant additive	Specification
G12evo	TL 774 L

The amount of coolant additive that needs to be mixed with water depends on the climate where the vehicle will be operated. If the coolant additive percentage is too low, the coolant can freeze and cause damage to the cooling system.

	Coolant additive	Freeze protection
Warm regions	min. 40% max. 45%	min. -13 °F (-25 °C)
Cold regions	min. 50% max. 55%	max. -40 °F (-40 °C)

! Note

- Before the start of winter, have an authorized Audi dealer or authorized Audi Service Facility check if the coolant additive in your vehicle matches the percentage appropriate for the climate. This is especially important when driving in colder climates.
- If the G12evo coolant additive is not available in an emergency, do not add any other additive. You could damage the motor and the high-voltage battery. If this happens, only use distilled water and restore the correct mixture ratio with the specified coolant additive as soon as possible.
- Only refill with new coolant.
- Radiator sealant must not be mixed with the coolant.
- You can continue driving if the permitted G12evo coolant additive was not added. However, go to an authorized Audi dealer or authorized Audi Service Facility immediately to have the coolant replaced in order to reduce the risk of damage to the motor and the high-voltage battery.
- Due to the risk of damage to the electric motor and the high-voltage battery, the cooling system should only be refilled by an authorized Audi dealer or authorized Audi Service Facility. An authorized Audi dealer or authorized Audi Service Facility can also provide you with important information about the recommended coolant additive.

Checking coolant

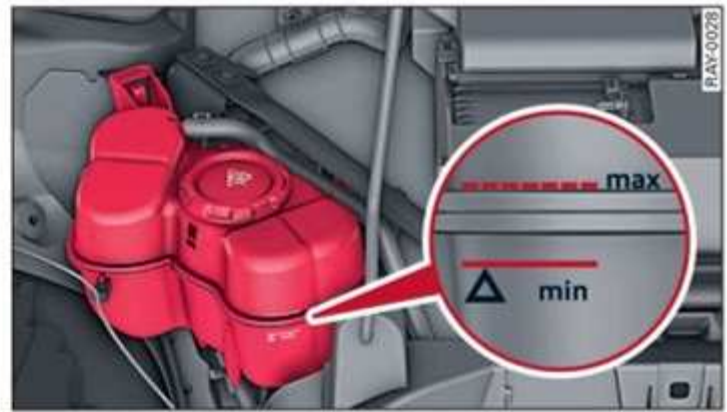

Fig. 152 Front compartment: coolant expansion tank (diagram)

Observe the safety precautions ⇒ page 229, General information.

Checking the coolant level

- ▶ Park the vehicle on a level surface.
- ▶ Switch the ignition off.
- ▶ Open the hood ⇒ page 230.
- ▶ Check the coolant level in the coolant expansion tank ⇒ page 232, fig. 151 using the outer markings ⇒ fig. 152. The coolant level must be between the min and max markings when the coolant is cold. When the coolant is warm, it can be slightly above the upper marking.

Adding coolant

See ⇒ ⚠.

Requirement: there must be a residual amount of coolant in the expansion tank ⇒ !.

If you must add coolant, use a mixture of water and coolant additive. Audi recommends mixing the coolant additive with distilled water.

- ▶ Allow the cooling system to cool down.
- ▶ Place a large, thick towel on the coolant expansion tank cap.
- ▶ Unscrew the cap ⇒ fig. 152 carefully by turning it to the left ⇒ ⚠.
- ▶ Add coolant mixed in the correct ratio ⇒ page 232 up to the max marking.
- ▶ Make sure that the fluid level remains stable. Add more coolant if necessary.
- ▶ Screw on the cap securely to the right. ▶

! WARNING

- The front compartment in any vehicle is a potentially dangerous area. Before performing work in the front compartment, switch the ignition off and allow the cooling system to cool down. Always follow the information found in ⇒ *page 229, General information*.
- Never open the hood if you can see or hear steam or coolant escaping from the front compartment, because there is a risk that you could be burned. The cooling system is under pressure. When you no longer see or hear steam or coolant escaping, you may open the engine compartment with caution.
- Coolant must not be added if the  indicator light turns on because doing so increases the risk of fire.
- Coolant additive and coolant can be dangerous to your health. For this reason, store the coolant in the original container and away from children. There is a risk of poisoning.

! Note

Coolant loss that results in the coolant expansion tank becoming nearly empty primarily indicates that there are significant leaks in the cooling system, which can lead to further damage.

- Do not add coolant if the expansion tank is empty. Air could enter the cooling system and increase the risk of damage. If this is the case, do not continue driving. See an authorized Audi dealer or authorized Audi Service Facility for assistance.
- If there is any coolant remaining, add additional coolant. Drive to an authorized Audi dealer or authorized Audi Service Facility immediately to have the malfunction corrected. If the  indicator light turns on again, do not continue driving and switch the ignition off. See an authorized Audi dealer or authorized Audi Service Facility for assistance.
- If a large amount (approximately 0.5 qt or 0.5 L) of coolant needed to be added, then check the coolant level again the next day. If the coolant level has decreased again, see

an authorized Audi dealer or authorized Audi Service Facility for assistance.

- If smaller amounts (0.25 qt or 0.25 L) of coolant needed to be added multiple times (up to two times) within two months, visit an authorized Audi dealer or authorized Audi Service Facility because there is a risk of damage.
- If there is too much coolant in the expansion tank after adding coolant, drive to an authorized Audi dealer or authorized Audi Service Facility as soon as possible to have the coolant level corrected.

Brake fluid



Fig. 153 Front compartment: brake fluid reservoir cover

Observe the safety precautions ⇒ *page 229, General information*.

Checking the brake fluid level

- ▶ Park the vehicle on a level surface.
- ▶ Read the brake fluid level on the brake fluid reservoir ⇒ *page 232, fig. 151*. The brake fluid level must be between the MIN and MAX markings ⇒ .

The brake fluid level is monitored automatically.

Messages

The following messages may appear depending on the vehicle equipment:

BRAKE /  **Brakes: stop vehicle and check brake fluid level**

Stop the vehicle and check the brake fluid level. See an authorized Audi dealer or authorized Audi Service Facility for assistance. ▶

Changing the brake fluid

Brake fluid should be changed at regular intervals. Have the brake fluid changed by an authorized Audi dealer or authorized Audi Service Facility. The authorized Audi dealer or authorized Audi Service Facility will inform you of the replacement intervals.

WARNING



- If the brake fluid level is below the MIN marking, it can impair the braking effect and driving safety, which increase the risk of an accident. Do not continue driving. See an authorized Audi dealer or authorized Audi Service Facility for assistance.
- If the brake fluid is old, bubbles may form in the brake system during heavy braking. This could impair braking performance and driving safety, which increases the risk of an accident.
- The brake fluid in your vehicle must meet the standard VW 501 14 and is available at an authorized Audi dealer or authorized Audi Service Facility. If this brake fluid is not available, another high-grade brake fluid of equivalent quality may be used, and it must meet the U.S. Federal Motor Vehicle Standard (FMVSS) 116 DOT 4, Class 6.
- Reusing brake fluid or using brake fluid that is not permitted for your vehicle will significantly impair the braking performance and can even lead to a failure of the brake system. The manufacturer of the vehicle is not liable for failures or damage resulting from this. It will also not be covered by the warranty.

Note

- If the brake fluid level is above the MAX marking, brake fluid may leak out over the edge of the reservoir and result in damage to the vehicle.
- Do not allow any brake fluid to come into contact with the vehicle paint, because it will corrode the paint.

Electrical system

The following messages may appear depending on the vehicle equipment:

If the  /  or  indicator light turns on, there is a malfunction in the power supply, the battery, or the vehicle electrical system.

/ Electrical system: malfunction! Safely stop vehicle

Safely stop your vehicle, do not continue driving and switch the ignition off \Rightarrow . See an authorized Audi dealer or authorized Audi Service Facility for assistance.

Electrical system: malfunction! Restart not possible. Please contact Service

If you switch the ignition off, you will not be able to restart the vehicle. Vehicle functions or driving stability may be limited. Drive to an authorized Audi dealer or authorized Audi Service Facility immediately.

Electrical system: malfunction! Please contact Service

Switch off all electrical equipment that is not needed. If necessary, some equipment will be switched off automatically. Vehicle functions or driving stability may be limited. Drive to an authorized Audi dealer or authorized Audi Service Facility immediately.

Electrical system: low battery charge. Battery will be charged while driving

- If this message turns off after a little while, the vehicle battery has been charged enough by the high-voltage battery while driving.
- If the message does not turn off, drive immediately to an authorized Audi dealer or authorized Audi Service Facility to have the malfunction repaired.

Electrical system: currently limited. Drive with greater care

The energy supply to the 12 volt electrical system is limited, for example because the 12 volt vehicle battery is drained or is not fully functional at this time. The 12 volt vehicle battery can be recharged while driving. Please drive carefully until ►

the message disappears. Turn off any unnecessary electrical equipment during that time. Have an authorized Audi dealer or authorized Audi Service Facility repair the malfunction if the indicator light does not turn off after some time.

WARNING

When there is an electrical system malfunction, vehicle functions may not work and driving stability may be limited, which increases the risk of an accident. Do not continue driving and switch the ignition off. See an authorized Audi dealer or authorized Audi Service Facility for assistance.

Battery

Battery general information

Because of the complex power supply, all work on batteries such as disconnecting, replacing, etc., should **only** be performed by an authorized Audi dealer or authorized Audi Service Facility ⇨ .

Batteries with different technologies are installed in your vehicle:

- 12 volt vehicle battery (for example, for basic power supply) ⇨ *page 237, Safety precautions*
- High-voltage battery (for example, for electric drive system, climate control) ⇨ *page 105, Introduction*

Not running the vehicle for long periods of time

If the vehicle is left parked for long periods of time, the 12 volt vehicle battery will drain gradually. To ensure that the vehicle can still be started, the electrical equipment will be limited or switched off. Some convenience functions, such as interior lighting or power seat adjustment, may not be available under certain circumstances. The convenience functions will be available again when you establish drive ready mode.

Even when electrical equipment is switched off, the equipment can still drain the 12 Volt vehicle battery if the vehicle is not driven for long periods of time. Deep draining results in a chemical

reaction that destroys the inside of the battery. The battery must be charged every month to prevent this ⇨ *page 238*. Contact an authorized Audi dealer or authorized Audi Service Facility for more information.

Winter operation

Cold weather places an especially high load on the 12 volt vehicle battery. Have the battery checked by an authorized Audi dealer or authorized Audi Service Facility before cold weather begins.

Replacing the battery

Applies to: 12 volt vehicle battery

All work on the battery must **only** be performed by an authorized Audi dealer or authorized Audi Service Facility.

The 12 volt vehicle battery was developed based on the installation location and is equipped with safety features. If a 12 volt vehicle battery must be replaced, ask your authorized Audi dealer or authorized Audi Service Facility about the electromagnetic compatibility, size, and the necessary maintenance, power, and safety standards for the new 12 volt vehicle battery. The battery vent of the 12 volt vehicle battery must always be on the negative terminal side. The battery vent on the positive terminal side must always be closed.

When replacing the 12 volt lead-acid vehicle battery, only use a maintenance-free 12 volt lead-acid battery that conforms to the TL 825 06 and VW 7 50 73 standards. These standards must be from October 2014 or newer.

WARNING

- All work on the battery or electrical system in your vehicle can result in injuries, chemical burns, accidents, or burns. Because of this, all work must be performed **only** by an authorized Audi dealer or authorized Audi Service Facility.
- Always have an authorized Audi dealer or authorized Audi Service Facility replace the 12 volt vehicle battery, because and adaptation must be performed on the vehicle electrical system when the battery is replaced.

Only an authorized Audi dealer or authorized Audi Service Facility has the necessary technology to perform the adaption correctly. Otherwise, there could be a loss of safety-related functions among other things, which increases the risk of an accident.

- Never connect a charging cable or jump start cable directly to the 12 volt vehicle battery. Only use the connections in the front compartment ⇒ *page 238*.

 **WARNING**

California Proposition 65 Warning:

- Battery posts, terminals and related accessories contain lead and lead compounds, chemicals known to the State of California to cause cancer and reproductive harms. Wash hands after handling.

 **Note**













- If the vehicle will be parked for long periods of time, protect the 12 volt vehicle battery against the cold so that it will not “freeze” and become damaged ⇒ *page 238, Charging the 12 volt vehicle battery*.
- Always have an authorized Audi dealer or authorized Audi Service Facility replace the 12 volt vehicle battery, because and adaptation must be performed on the vehicle electrical system when the battery is replaced. Only an authorized Audi dealer or authorized Audi Service Facility has the necessary technology to perform the adaption correctly.
- Using unsuitable batteries may void the vehicle’s operating license.



 **For the sake of the environment**

 Batteries and electrical/electronic devices must be disposed of in an environmentally safe manner ⇒ *page 291, Disposal instructions*.

Safety precautions

Explanation of warning symbols:

	Observe all warnings - there is a risk for injury!
	Always follow the instructions in the operating manual.
	High voltage! The voltage in the high-voltage system is high enough to cause fatal injuries. Touching a damaged high-voltage component can result in a fatal electric shock.
	
	
	Electrolyte fluid is highly corrosive. Always wear protective gloves and eye protection. First aid: if electrolyte fluid enters the eyes, immediately flush with clean water for several minutes. Seek medical attention immediately. Immediately neutralize electrolyte fluid on the skin or clothing using a soap solution and rinse with plenty of water. Seek medical attention immediately if electrolyte fluid is ingested.
	Always wear eye protection.
	If electrolyte fluid enters the eyes, immediately flush with clean water for several minutes. Seek medical attention immediately.
	Fire, sparks, open flame, and smoking are prohibited. Avoid creation of sparks and short circuits when handling cables and electrical devices.
	The high-voltage battery is flammable. The high-voltage battery must never be exposed to fire, sparks, or open flame. Always handle the high-voltage battery with care to reduce the risk of damage and leaking fluids.
	Always keep children away from battery electrolyte fluid and the battery.
	A highly explosive mixture of gases can form when charging batteries.

	<p>Applies to: high-voltage battery: Handling the high-voltage battery incorrectly can lead to serious injuries or death. Never remove the cover from the high-voltage battery and never disassemble the high-voltage battery.</p>
	<p>Applies to: high-voltage battery: Handling the high-voltage battery incorrectly can lead to serious injuries or death. The high-voltage battery must only be serviced by qualified and trained technicians. Never make modifications to the high-voltage battery. If the high-voltage battery is open, it must not come into contact with water or other liquids. Liquids may cause short circuits, electric shocks, and burns. Have the high-voltage battery replaced only by an authorized Audi dealer or authorized Audi Service Facility. Audi recommends an authorized Audi dealer or authorized Audi Service Facility, because these locations have trained personnel and the required parts and tools.</p>
	<p>Applies to: high-voltage battery: Handling the high-voltage battery incorrectly can lead to serious injuries or death. The high-voltage battery must only be serviced by qualified and trained technicians. Never make modifications to the high-voltage battery. If the high-voltage battery is open, it must not come into contact with water or other liquids. Liquids may cause short circuits, electric shocks, and burns. Have the high-voltage battery replaced only by an authorized Audi dealer or authorized Audi Service Facility. Audi recommends an authorized Audi dealer or authorized Audi Service Facility, because these locations have trained personnel and the required parts and tools.</p>

WARNING

- All work on the batteries must **only** be performed by an authorized Audi dealer or authorized Audi Service Facility.
- Gases that escape from these batteries can be poisonous or flammable.
 - The contents of these batteries can be corrosive. If any battery contents come into contact with the skin, flush the affected area for at least 15 minutes with clean water. Then wash the affected area with soap. Have the affected area examined by a medical professional.

Charging the 12 volt vehicle battery

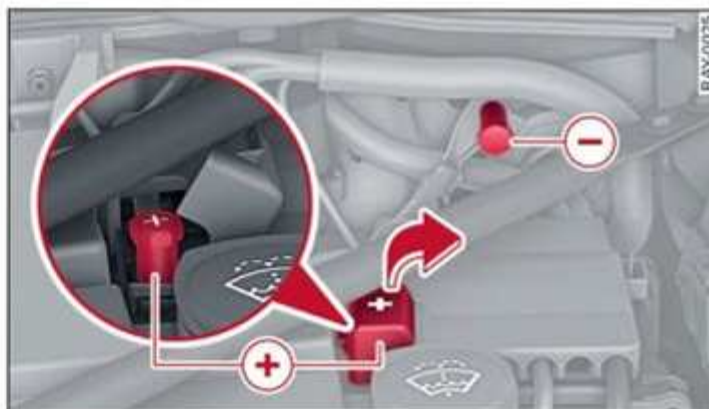







Fig. 154 Front compartment: connectors for a charger or jump start cables

Observe the safety precautions ⇒ *page 229, General information*, ⇒  in *Battery general information on page 236* and ⇒ .

Requirement: only use chargers with a **maximum charging current of 14.8 volts**. The battery cables remain connected.

The charging cable connections are located in the front compartment. The ground point  is always located on the vehicle body.

- ▶ Switch off the ignition and all electrical equipment.
- ▶ Open the hood ⇒ *page 230*.
- ▶ Open the cover on the positive terminal ⇒ *fig. 154*.
- ▶ Clamp the terminal clamps on the charger correctly onto the positive terminal  and the ground point .
- ▶ Insert the power cable for the charger into the socket and switch the charger on.
- ▶ At the end of the charging process, switch the charger off and pull the power cable out of the socket.
- ▶ Remove the charger terminal clamps.
- ▶ Close the cover on the positive terminal.
- ▶ Close the hood ⇒ *page 230*.

WARNING

- Never use charging equipment that is unsuitable, visibly damaged, and/or dirty. Check the charging equipment for damage before every use.
- Never connect a charging cable or jump start cable directly to the 12 volt vehicle

- battery. Only use the connections in the front compartment ⇒ *page 238*.
- A highly explosive mixture of gases can form when charging batteries. Only charge the battery in well-ventilated areas.
 - A drained battery can freeze at temperatures around 32 °F (0 °C). Do not charge or use a frozen or thawed battery. If ice forms, the battery housing can crack and battery electrolyte fluid can leak, which increases the risk of an explosion and chemical burns. Contact an authorized Audi dealer or authorized Audi Service Facility for more information.
 - Do not connect or disconnect the charging cable while charging because this increases the risk of an explosion.

i Tips

- Only charge the battery using the connections in the front compartment.
- Read all of the manufacturer's instructions for the charger before charging the battery.

Windshield washer system



Fig. 155 Front compartment: washer fluid reservoir cover

Observe the safety precautions ⇒ *page 229, General information*.

The windshield washer reservoir  contains the cleaning solution for the windshield/rear window and the headlight washer system* ⇒ *fig. 155, page 232*. The reservoir capacity can be found in ⇒ *page 289*.

To reduce the risk of lime scale deposits on the spray nozzles, use clean water with low amounts

of calcium. Always add window cleaner to the water. When the outside temperatures are cold, an anti-freezing agent should be added to the water so that it does not freeze.

Messages

The following messages may appear depending on the vehicle equipment:

 **Please add washer fluid**

Fill the washer fluid for the windshield washer system and the headlight washer system* when the ignition is switched off.

 **Note**

- The concentration of anti-freezing agent must be adjusted to the vehicle operating conditions and the climate. A concentration that is too high can lead to vehicle damage.
- Never add radiator anti-freeze or other additives to the washer fluid.
- Do not use a glass cleaner that contains paint solvents, because this could damage the paint.

Service interval display

The service interval display detects when your vehicle is due for service.

The service interval display works in two stages:

- **Inspection reminder:** after driving a certain distance and depending on vehicle equipment, a message will appear in the instrument cluster display each time the ignition is switched on or off.
- **Inspection due:** if your vehicle has reached an inspection interval, the message **Inspection due!** appears briefly after the ignition is switched on and off.

Checking service intervals

You can check the remaining distance or time until the next service.

Applies to MMI: Select on the home screen: **VEHICLE > Settings & Service > Service intervals** ▶

WARNING

Inadequate service, a lack of service, or failing to adhere to the service intervals can result in the vehicle breaking down in traffic, accidents, and serious injuries.

Note

- Regular service work on the vehicle is not only beneficial for the sustainable use and retention of the vehicle value, but also for the operational and traffic safety. For this reason, always have service work performed according to the Audi guidelines.
- Even if the mileage on the vehicle is low, do not exceed the time for the next service.
- Audi is not responsible for damage to the vehicle that occurred due to inadequate service or insufficient part availability.

Wheels

Tires and rims

General information

The combination of a rim and tire will be referred to as a wheel in this Owner's Manual. If only one of the components is referred to, then the term tire or rim will be used.

- ▶ Check your tires regularly for damage, such as punctures, cuts, cracks, and bulges. Remove foreign objects from the tire tread.
- ▶ If driving over curbs or similar obstacles, drive slowly and approach the curb at an angle.
- ▶ Have faulty tires or rims replaced immediately.
- ▶ Protect your tires from oil, grease, and fuel.
- ▶ Mark tires before removing them so that the same running direction can be maintained if they are reinstalled.
- ▶ Lay tires flat when storing and store them in a cool, dry location with as little exposure to light as possible.



WARNING

- Never drive faster than the maximum permitted speed for your tires. This could cause the tires to heat up too much. This increases the risk of an accident because it can cause the tire to burst.
- Always adapt your driving to the road and traffic conditions. Drive carefully and reduce your speed on icy or slippery roads. Even winter tires can lose traction on black ice.



Note

- Please note that summer and winter tires are designed for the conditions that are typical in those seasons. Audi recommends winter tires during the winter months. Low temperatures significantly decrease the elasticity of summer tires, which affects traction and braking ability. If summer tires are used in very cold temperatures, cracks can form on the tread bars, resulting in permanent tire damage that can cause loud driving noise and unbalanced tires.

–Burnished, polished or chromed rims must not be used in winter driving conditions. The surface of the rims does not have sufficient corrosion protection for this and could be permanently damaged by road salt or similar substances. The exception to this are rims that are part of complete winter wheels provided by the factory.

Tire designations

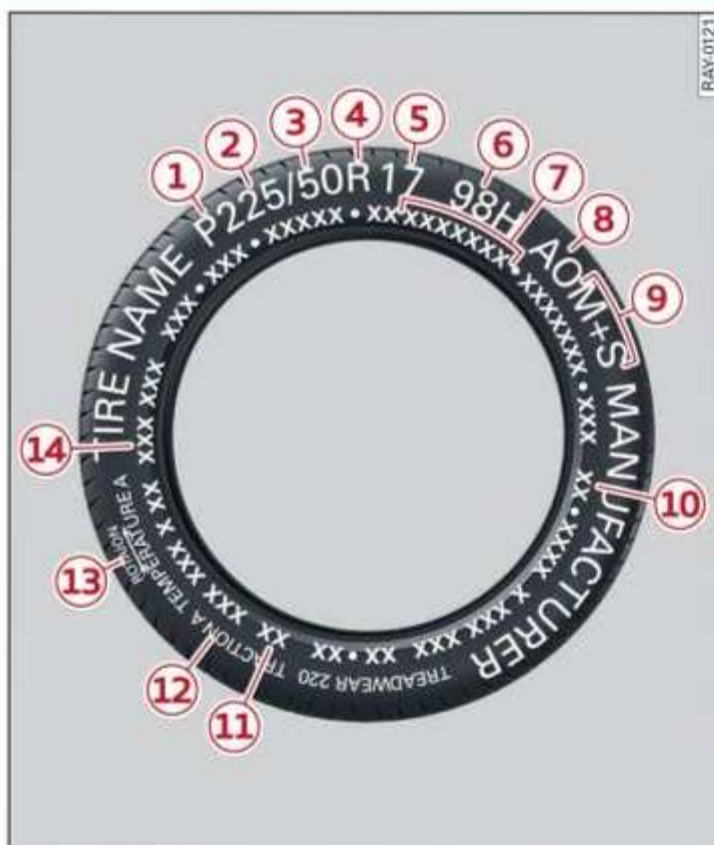

Fig. 156 Tire designations on the sidewall

① Tires for passenger vehicles (if applicable)

“P” indicates a tire for a passenger vehicle. “T” indicates a tire designated for temporary use.

HL indicates High Load Capacity tires.

② Nominal width

Nominal width of the tire between the sidewalls in millimeters. In general: the larger the number, the wider the tire.

③ Aspect ratio

Height/width ratio expressed as a percentage.

④ Tire construction

“R” indicates a radial tire.

⑤ Rim diameter

Size of the rim diameter in inches.

⑥ Load index and speed rating

The load index indicates the tire's load-carrying capacity.

The speed rating indicates the maximum permitted speed. Also see ⇨ **▲** in *General information on page 241*.

“EXTRA LOAD”, “xl” or “RF” indicates that the tire is reinforced or is an Extra Load tire. ▶

Speed rating	Maximum permitted speed
P	up to 93 mph (150 km/h)
Q	up to 99 mph (160 km/h)
R	up to 106 mph (170 km/h)
S	up to 110 mph (180 km/h)
T	up to 118 mph (190 km/h)
U	up to 124 mph (200 km/h)
H	up to 130 mph (210 km/h)
V	up to 149 mph (240 km/h) ^{a)}
Z	above 149 mph (240 km/h) ^{a)}
W	up to 168 mph (270 km/h) ^{a)}
Y	up to 186 mph (300 km/h) ^{a)}

^{a)} For tires above 149 mph (240 km/h), tire manufacturers sometimes use the code “ZR”.

⑦ US DOT number (TIN) and manufacture date

The manufacture date is listed on the tire sidewall (it may only appear on the inner side of the tire):

DOT ... 2223 ...

means, for example, that the tire was produced in the 22nd week of the year 2023.

⑧ AO or RO

Tires with the designation “AO” or “RO” that have been specifically matched to your Audi are installed at the factory. When used correctly, these tires meet very high standards for safety and handling. An authorized Audi dealer or authorized Audi Service Facility

will be able to provide you with more information.

⑨ Mud and snow capability

“M/S” or “M+S” indicates the tire is suitable for driving on mud and snow.  indicates a winter tire.

⑩ Composition of the tire cord and materials

The number of plies indicates the number of rubberized fabric layers in the tire. In general: the more layers, the more weight a tire can carry. Tire manufacturers must also specify the materials used in the tire. These include steel, nylon, polyester and other materials.

⑪ Maximum permitted load

This number indicates the maximum load in kilograms and pounds that the tire can carry.

⑫ Uniform tire quality grade standards for treadwear, traction and temperature resistance

Treadwear, traction, and temperature ranges ⇨ *page 257*.

⑬ Running direction

The arrows indicate the running direction of unidirectional tires. ▶

You must always follow the specified running direction
⇒ *page 272*.

14 Maximum permitted inflation pressure

This number indicates the maximum pressure to which a tire can be inflated under normal operating conditions.

Glossary of tire and loading terminology

Accessory weight

means the combined weight (in excess of those standard items which may be replaced) of automatic transmission, power steering, power brakes, power windows, power seats, radio, and heater, to the extent that these items are available as factory-installed equipment (whether installed or not).

Aspect ratio

means the ratio of the height to the width of the tire in percent. Numbers of 55 or lower indicate a low sidewall for improved steering response and better overall handling on dry pavement.

Bead

means the part of the tire that is made of steel wires, wrapped or reinforced by ply cords and that is shaped to fit the rim.

Bead separation

means a breakdown of the bond between components in the bead.

Cord

means the strands forming the plies in the tire.

Cold tire inflation pressure

means the tire pressure recommended by the vehicle manufacturer for a tire of a designated size that has not been driven for more than a couple of miles (kilometers) at low speeds in the three hour period before the tire pressure is measured or adjusted.

Curb weight

means the weight of a motor vehicle with standard equipment including the maximum capacity of fuel, oil, and coolant, air conditioning and additional weight of optional equipment.

Extra load tire

means a tire designed to operate at higher loads and at higher

inflation pressures than the corresponding standard tire. Extra load tires may be identified as “XL”, “xl”, “EXTRA LOAD”, or “RF” on the sidewall.

Gross Axle Weight Rating (“GAWR”)

means the load-carrying capacity of a single axle system, measured at the tire-ground interfaces.

Gross Vehicle Weight Rating (“GVWR”)

means the maximum total loaded weight of the vehicle.

Groove

means the space between two adjacent tread ribs.

High load capacity tire

High load capacity tires are extra load tires that are designed to carry a higher load at the same pressure. High load capacity tires are identified with the prefix “HL” in front of the tire size designation.

Load rating (code)

means the maximum load that a tire is rated to carry for a given inflation pressure. You may not find

this information on all tires because it is not required by law.

Maximum load rating

means the load rating for a tire at the maximum permissible inflation pressure for that tire.

Maximum loaded vehicle weight

means the sum of:

- (a) Curb weight
- (b) Accessory weight
- (c) Vehicle capacity weight, and
- (d) Production options weight

Maximum (permissible) inflation pressure

means the maximum cold inflation pressure to which a tire may be inflated. Also called “maximum inflation pressure.”

Normal occupant weight

means 150 lbs. (68 kilograms) times the number of occupants seated in the vehicle up to the total seating capacity of your vehicle.

Occupant distribution

means distribution of occupants in a vehicle. ►

Outer diameter

means the overall diameter of an inflated new tire.

Overall width

means the linear distance between the exteriors of the sidewalls of an inflated tire, including elevations due to labeling, decorations, or protective bands or ribs.

Ply

means a layer of rubber-coated parallel cords.

Production options weight

means the combined weight of those installed regular production options weighing over 5 lbs.

(2.3 kg) in excess of those standard items which they replace, not previously considered in curb weight or accessory weight, including heavy duty brakes, ride levelers, roof rack, heavy duty battery, and special trim.

Radial ply tire

means a pneumatic tire in which the ply cords that extend to the beads are laid at substantially 90 degrees to the centerline of the tread.

Recommended inflation pressure

see ⇒ *page 244, Cold tire inflation pressure.*

Reinforced tire

means a tire designed to operate at higher loads and at higher inflation pressures than the corresponding standard tire. Reinforced tires may be identified as “XL”, “xl”, “EXTRA LOAD”, or “RF” on the sidewall.

Rim

means a metal support for a tire or a tire and tube assembly upon which the tire beads are seated.

Rim diameter

means nominal diameter of the bead seat. If you change your wheel size, you will have to purchase new tires to match the new rim diameter.

Rim size designation

means rim diameter and width.

Rim width

means nominal distance between rim flanges. ▶

Sidewall

means that portion of a tire between the tread and bead.

Speed rating (letter code)

means the speed at which a tire is designed to be driven for extended periods of time. The ratings range from 93 mph (150 km/h) to 186 mph (298 km/h) ⇒ *table on page 243*. You may not find this information on all tires because it is not required by law.

The speed rating letter code, where applicable, is molded on the tire sidewall and indicates the maximum permissible road speeds. See also ⇒  *in General information on page 241*.

Tire pressure monitoring system

means a system that detects when one or more of a vehicle's tires are underinflated and illuminates a low tire pressure warning telltale.

Tread

means that portion of a tire that comes into contact with the road.

Tread separation

means pulling away of the tread from the tire carcass.

Treadwear indicators (TWI)

means the projections within the principal grooves designed to give a visual indication of the degrees of wear of the tread. See ⇒ *page 251, Treadwear indicator* for more information on measuring tire wear.

Uniform Tire Quality Grading

is a tire information system developed by the United States National Highway Traffic Safety Administration (NHTSA) that is designed to help buyers make relative comparisons among tires. The UTQG is not a safety rating and not a guarantee that a tire will last for a prescribed number of miles (kilometers) or perform in a certain way. It simply gives tire buyers additional information to combine with other considerations, such as price, brand loyalty and dealer recommendations. Under UTQG, tires are graded by the tire manufacturers in three areas: ►

treadwear, traction, and temperature resistance. The UTQG information on the tires, molded into the sidewalls.

U.S. DOT Tire Identification Number (TIN)

This is the tire's "serial number". It begins with the letters "DOT" and indicates that the tire meets all federal standards. The next two numbers or letters indicate the plant where it was manufactured, and the last four numbers represent the week and year of manufacture. For example,

DOT ... 2223 ...

means that the tire was produced in the 22nd week of 2023. The other numbers are marketing codes that may or may not be used by the tire manufacturer. This information is used to contact consumers if a tire defect requires a recall.

Vehicle capacity weight

means the rated cargo and luggage load plus 150 lbs. (68 kilograms) times the vehicle's designated seating capacity.

Vehicle maximum load on the tire

means that load on an individual tire that is determined by distributing to each axle its share of the maximum loaded vehicle weight and dividing by two.

Vehicle normal load on the tire

means that load on an individual tire that is determined by distributing to each axle its share of the curb weight, accessory weight, and normal occupant weight (distributed in accordance with \Rightarrow *table on page 253*) and dividing by two.

Occupant loading and distribution for vehicle normal load for various designated seating capacities

Refer to the tire inflation pressure label \Rightarrow *page 252, fig. 159* for the number of seating positions. Refer to the table \Rightarrow *table on page 253* for the number of people that correspond to the vehicle normal load.

New tires or wheels

Audi recommends having all work on tires or wheels performed by an authorized Audi dealer or ▶

authorized Audi Service Facility. These facilities have the proper knowledge and are equipped with the required tools and replacement parts.

- ▶ New tires do not yet have the optimal gripping properties. Drive carefully and at moderate speeds for the first 350 miles (500 km) with new tires.
- ▶ Tires with different dimensions on the front and rear axle are installed as standard equipment. Use tires of the same dimension, construction, size (rolling circumference), and tread pattern on each axle.
- ▶ Do not replace tires individually. At least replace both tires on the same axle at the same time.
- ▶ Audi recommends using Audi Genuine Tires. If you would like to use different tires, please note that the tires may perform differently even if they are the same size ⇒ ⚠.
- ▶ If you would like to equip your vehicle with a tire and rim combination that is different from what was installed at the factory, consult with an authorized Audi dealer or authorized Audi

Service Facility before making a purchase ⇒ ⚠.

Because the spare tire* is different from the regular tires installed on the vehicle (such as winter tires or wide tires), only use the spare tire* temporarily in case of emergency and drive carefully while it is in use. It should be replaced with a regular tire as soon as possible.

Applies to: vehicles with all wheel drive: All four wheels must be equipped with tires that are the same brand and have the same construction and tread pattern so that the drive system is not damaged by different wheel speeds. For this reason, in case of emergency, only use a spare tire* that is the same circumference as the regular tires.

WARNING

- Only use tire/rim combinations and suitable wheel bolts that have been approved by Audi. Otherwise, damage to the vehicle and an accident could result.
- For technical reasons, it is not possible to use tires from

other vehicles. In some cases, you cannot even use tires from the same vehicle model.

- Make sure that the tires you select have enough clearance to the vehicle. Replacement tires should not be chosen simply based on the nominal size, because tires with a different construction can differ greatly even if they are the same size. If there is not enough clearance, the tires or the vehicle can be damaged and this can reduce driving safety and increase the risk of an accident.
- Only use tires that are more than six years old when absolutely necessary and drive carefully when doing so.
- Do not use run-flat tires on your vehicle. Using them when not permitted can lead to vehicle damage or accidents.
- If you install wheel covers on the vehicle, make sure they allow enough air circulation to cool the brake system. If they do not, this could increase the risk of an accident.
- Mounting a tire on the rim incorrectly can result in tire

damage or failure. To reduce the risk of an accident, only trained personnel may mount a tire on the rim.

Tire wear and damage



Fig. 157 Tire profile: treadwear indicator

Tire wear

Check the tires regularly for wear.

- Inflation pressure that is too low or high can increase tire wear considerably.
- Driving quickly through curves, rapid acceleration, and heavy braking increase tire wear. When driving under these conditions, check the tread depth every 3,100 miles (5,000 km) to 6,200 miles (10,000 km).
- Have an authorized Audi dealer or authorized Audi Service Facility check the wheel alignment if there is unusual wear.
- Have the wheels rebalanced if an imbalance is causing noticeable ►

vibration in the steering wheel. If you do not, the tires and other vehicle components could wear more quickly.

Treadwear indicator

Original equipment tires contain treadwear indicators in the tread pattern, which are bars that are 1/16 inch (1.6 mm) high and are spaced evenly around the tire perpendicular to the running direction ⇒ *fig. 157*. The letters “TWI” or triangles on the tire sidewall indicate the location of the treadwear indicators.

When checking tread depth, you must check the wear indicators across the entire width of the tire and on all four tires.

The tires have reached the minimum tread depth ¹⁾ when they have worn down to the treadwear indicators. Replace the tires with new ones ⇒ .

Tire rotation

Tires with different dimensions on the front and rear axle are installed as standard equipment.

The wider tires are mounted on the rear axle. The tires must not be rotated.

For unidirectional tires, make sure the tires are installed according to the running direction indicated on the tire sidewall ⇒ *page 272*.

Hidden damage

Damage to tires and rims can often occur in locations that are hidden. Unusual vibrations in the vehicle or pulling to one side may indicate that there is tire damage. Reduce your speed immediately. Check the tires for damage. If no damage is visible from the outside, drive slowly and carefully to the nearest authorized Audi dealer or authorized Audi Service Facility to have the vehicle inspected.



WARNING

Tread that has worn too low or uneven tread depths on the tires can reduce driving safety. This can increase the risk of an accident because it has a

¹⁾ Obey any applicable regulations in the country where the vehicle is being operated.

negative effect on handling, driving through curves, and braking, and because it increases the risk of hydroplaning when driving through deep puddles.

Tire pressure



Fig. 158 Driver's side B-pillar: tire pressure label

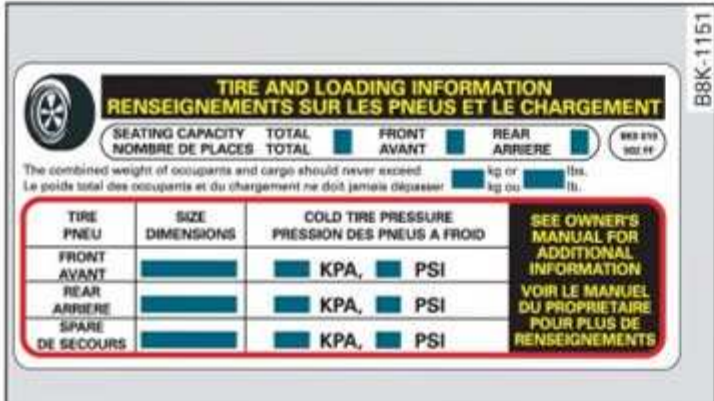

Fig. 159 Tire pressure label

The correct tire pressure for tires installed at the factory is listed on a label. The label is located on the B-pillar (driver's side) ⇒ *fig. 158*, ⇒ *fig. 159*. The location may vary depending on the model.

Use the tire pressure specified for a normal vehicle load when the

vehicle is partially loaded ⇒ *table on page 253*. If driving the vehicle when fully loaded, you must increase the tire pressure to the maximum specified pressure

⇒ ⚠.

Checking and correcting tire pressure

- ▶ Check the tire pressure at least once per month and also check it before every long drive.
- ▶ Always check the tire pressure when the tires are *cold*. Do not reduce the pressure if it increases when the tires are warm.
- ▶ Refer to the sticker ⇒ *fig. 159* for the correct tire pressure.
- ▶ Correct the tire pressure if necessary.
- ▶ Save the changed tire pressure ⇒ *page 260*.



WARNING

Always adapt the tire pressure to your driving style and the vehicle load.

–Overloading can lead to loss of vehicle control and increase the risk of an accident. Read and follow the important safety precautions in ⇒ *page 254*.

- The tire must flex more if the tire pressure is too low or if the vehicle speed or load are too high. This heats the tire up too much. This increases the risk of an accident because it can cause the tire to burst and result in loss of vehicle control.
- Incorrect tire pressure increases tire wear and has a negative effect on driving and braking

behavior, which increases the risk of an accident.



Note

Replace lost valve caps to reduce the risk of damage to the tire valves.



For the sake of the environment

Tire pressure that is too low increases energy use.

Tire pressure table

Please note that the information contained in the following table was correct at the time of printing, and the information is subject to change. If there are any differences, you should always follow the tire pressure sticker ⇒ *page 252, fig. 158.*

Make sure that the tire designation on your tire matches the designation on the tire pressure label and the tire pressure table.

The following table lists recommended tire pressures in cold tires according to the load and the size of the tires installed.

Model	Tire designation	Tire pressure			
		Maximum load			
		Front		Rear	
		kPA	PSI	kPA	PSI
Q4 e-tron 40	235/55 R19 105T	290	42	-	-
	255/50 R19 107T	-	-	290	42
	235/50 R20 104T	290	42	-	-
	255/45 R20 105T	-	-	290	42
Q4 e-tron 50 quattro and Q4 Sportback e-tron 50 quattro	235/55 R19 105T	300	44	-	-
	255/50 R19 107T	-	-	300	44
	235/50 R20 104T	300	44	-	-
	255/45 R20 105T	-	-	300	44

**WARNING**

Please note the important safety precautions regarding tire pressure ⇒ *page 252* and load limits ⇒ *page 254*.

Tires and vehicle load limits

There are limits to the amount of load or weight that any vehicle and any tire can carry. A vehicle that is overloaded will not handle well and is more difficult to stop. Overloading can not only lead to loss of vehicle control, but can also damage important parts of the vehicle and can lead to sudden tire failure, including a blowout and sudden deflation that can cause the vehicle to crash.

Your safety and that of your passengers also depends on making sure that load limits are not exceeded. Vehicle load includes everybody and everything in and on the vehicle. These load limits are technically referred to as the vehicle's **Gross Vehicle Weight Rating** ("GVWR").

The "GVWR" includes the weight of the basic vehicle, all factory installed accessories, a full tank of fuel, oil, coolant and other fluids

plus maximum load. The maximum load includes the number of passengers that the vehicle is intended to carry ("seating capacity") with an assumed weight of 150 lbs. (68 kg) for each passenger at a designated seating position and the total weight of any luggage in the vehicle. If you tow a trailer, the weight of the trailer hitch and the tongue weight of the loaded trailer must be included as part of the vehicle load.

The **Gross Axle Weight Rating** ("GAWR") is the maximum load that can be applied at each of the vehicle's two axles.

The fact that there is an upper limit to your vehicle's Gross Vehicle Weight Rating means that the total weight of whatever is being carried in the vehicle (including the weight of a trailer hitch and the tongue weight of the loaded trailer) is limited. The more passengers in the vehicle or passengers who are heavier than the standard weights assumed mean that less weight can be carried as luggage.

The Gross Vehicle Weight Rating and the Gross Axle Weight Rating ►

are listed on the safety compliance sticker label located on the driver's side B-pillar.



WARNING

Overloading a vehicle can cause loss of vehicle control, a crash or other accident, serious personal injury, and even death.

–Carrying more weight than your vehicle was designed to carry will prevent the vehicle from handling properly and increase the risk of the loss of vehicle control.

–The brakes on a vehicle that has been overloaded may not be able to stop the vehicle within a safe distance.

–Tires on a vehicle that has been overloaded can fail suddenly, including a blowout and sudden deflation, causing loss of control and a crash.

–Always make sure that the total load being transported – including the weight of a trailer hitch and the tongue weight of a loaded trailer – does not make the vehicle heavier than the vehicle's Gross Vehicle Weight Rating.

Determining correct load limit

Use the example below to calculate the total weight of the passengers and luggage or other things that you plan to transport so that you can make sure that your vehicle will not be overloaded.

Steps for Determining Correct Load Limit

1. Locate the statement "THE COMBINED WEIGHT OF OCCUPANTS AND CARGO SHOULD NEVER EXCEED XXX KG OR XXX LBS" on your vehicle's placard (tire inflation pressure label) ⇒ *page 252, fig. 159.*
2. Determine the combined weight of the driver and passengers that will be riding in your vehicle.
3. Subtract the combined weight of the driver and passengers from "XXX" kilograms or "XXX" pounds shown on the sticker ⇒ *page 252, fig. 159.*
4. The resulting figure equals the available amount of cargo and luggage load capacity. For example, if the "XXX" amount equals 1400 lbs. and there will ►

be five 150 lbs. passengers in your vehicle, the amount of available cargo and luggage load capacity is 650 lbs. (1400-750 (5 x 150) = 650 lbs.)

5. Determine the combined weight of luggage and cargo being loaded on the vehicle. That weight may not safely exceed the available cargo and luggage load capacity calculated in Step 4.
 6. If your vehicle will be towing a trailer, load from your trailer will be transferred to your vehicle. Consult this manual to determine how this reduces the available cargo and luggage load capacity of your vehicle.
- ▶ Check the tire sidewall (⇒ page 242, fig. 156) to determine the designated load rating for a specific tire.

Wheel bolts and rims

Wheel bolts

Wheel bolts must be clean and loosen/tighten easily.

Rims

Rims with a bolted rim ring* or with bolted wheel covers* consist of multiple pieces. These components were bolted together using special bolts

and a special procedure. You must not repair or disassemble them ⇒ ⚠.

WARNING

Wheel bolts that are tightened or repaired incorrectly can become loose and result in loss of vehicle control, which increases the risk of an accident. For the correct tightening specification, see ⇒ page 272, *Finishing*.

- Always keep the wheel bolts and the threads in the wheel hub clean and free of grease.
- Only use wheel bolts that fit the rim.
- Always have damaged rims repaired by an authorized Audi dealer or authorized Audi Service Facility. Never repair or disassemble rims yourself, because this increases the risk of an accident.

Winter tires

Winter tires significantly improve the vehicle's handling when driving in winter conditions. Because of their construction (width, compound, tread pattern), summer tires provide less traction on ice and snow.

- ▶ Use winter tires on all four wheels.
- ▶ Only use winter tires that are approved for your vehicle.
- ▶ Please note that the maximum permitted speed may be lower with winter tires ⇒ ⚠ in *General information on page 241*. An authorized Audi dealer or authorized Audi Service Facility can inform you about the maximum permitted speed for your tires.
- ▶ Check the tire pressure after installing wheels ⇒ page 252.

The effectiveness of winter tires is reduced greatly when the tread is worn down to a depth of 0.16 in (4 mm). The characteristics of winter tires also decrease greatly as the tire ages, regardless of the remaining tread.

For the sake of the environment

Reinstall summer tires at the appropriate time, because they provide better handling when roads are free of snow and ice. Summer

tires cause less road noise, tire wear, and energy use.

Tips

You can also use all season tires instead of winter tires. Please note that in some countries where winter tires are required, only winter tires with the  symbol may be permitted.

Snow chains

Snow chains improve both driving and braking in winter road conditions.

- ▶ Only install snow chains on the rear wheels.
- ▶ Check and correct the seating of the snow chains after driving a few feet, if necessary. Follow the instructions from the manufacturer.
- ▶ Note the maximum speed of 30 mph (50 km/h). Observe the local regulations.

Use of snow chains is only permitted with certain rim/tire combinations due to technical reasons. Check with an authorized Audi dealer or authorized Audi Service Facility to see if you may use snow chains.

Use **fine-mesh snow chains**. They must not add more than 0.47 inch (12 mm) in height, including the chain lock.

You must remove the snow chains on roads without snow. Otherwise, you could impair driving ability and damage the tires.

WARNING

Using incorrect snow chains or installing snow chains incorrectly can result in loss of vehicle control, which increases the risk of an accident.

Note

Snow chains can damage the rims and wheel covers* if the chains come into direct contact with them. Remove the wheel covers* first. Use coated snow chains.

Tips

When using snow chains, it may be advisable to limit the ESC \Rightarrow *page 103*.

Low-profile tires

Applies to: vehicles with low-profile tires

Compared to other tire/rim combinations, low-profile tires offer a wider tread surface and a larger rim diameter with shorter tire sidewalls. This results in an agile driving style. However, it may reduce the level of comfort and increase road noise when driving on roads in poor condition.

Low-profile tires can become damaged more quickly than standard tires when driving over large bumps, potholes, manhole covers, and curbs. Therefore, it is particularly important to maintain the correct tire pressure \Rightarrow *page 252*.

To reduce the risk of damage to the tires and rims, drive very carefully on poor roads.

Check your wheels regularly every 2,000 miles (3,000 km) for damage. For example, check for bulges/cracks on the tires or deformations/cracks on the rims.

After a heavy impact or damage, have the tires and rims inspected or replaced immediately by an authorized Audi dealer or authorized Audi Service Facility.

Low-profile tires can wear out faster than standard tires.

Uniform tire quality grading

- Tread wear
- Traction AA A B C
- Temperature A B C

Quality grades can be found where applicable on the tire side wall between tread shoulder and maximum section width \Rightarrow *page 242, fig. 156*.

For example: Tread wear **200**, Traction **AA**, Temperature **A**.

All passenger car tires must conform to Federal Safety Requirements in addition to these grades. ▶

Tread wear

The *tread wear* grade is a comparative rating based on the wear rate of the tire when tested under controlled conditions on a specified government test course.

For example, a tire graded 150 would wear one and one half (1 1/2) times as well on the government course as a tire graded 100.

The relative performance of tires depends upon the actual conditions of their use, however, and may depart significantly from the norm due to variations in driving habits, service practices and differences in road characteristics and climate.

Traction

The *traction* grades, from highest to lowest, are AA, A, B and C. Those grades represent the tire's ability to stop on wet pavement as measured under controlled conditions on specified government test surfaces of asphalt and concrete. A tire marked C may have poor traction performance ⇒ ⚠.

Temperature

The *temperature* grades are A (the highest), B, and C, representing the tire's resistance to the generation of heat and its ability to dissipate heat when tested under controlled conditions on a specified indoor laboratory test wheel.

Sustained high temperature can cause the material of the tire to degenerate and reduce tire life, and excessive temperature can lead to sudden tire failure ⇒ ⚠.

The grade C corresponds to a level of performance which all passenger car tires must meet under the Federal Motor Vehicle Safety Standard No. 109. Grades B and A represent higher levels of performance on the laboratory test wheel than the minimum required by law.

WARNING

The temperature grade for this tire is established for a tire that is properly inflated and not overloaded. Excessive speed, underinflation, or excessive loading, either separately or in combination, can cause heat buildup and possible tire failure.

WARNING

Temperature grades apply to tires that are properly inflated and not over or underinflated.

Tire pressure monitoring system

General notes

Each tire, including the spare (if provided), should be checked monthly when cold and inflated to the inflation pressure recommended by the vehicle manufacturer on the vehicle placard or tire inflation pressure label. (If your vehicle has tires of a different size than the size indicated on the vehicle placard or tire inflation pressure label, you should determine the proper tire inflation pressure for those tires).

As an added safety feature, your vehicle has been equipped with a tire pressure monitoring system (TPMS) that illuminates a low tire pressure telltale when one or more of your tires is significantly under-inflated. Accordingly, when the low tire pressure telltale illuminates, you should stop and check your tires as soon as possible, and inflate them to the proper pressure. Driving on a significantly under-inflated tire causes the tire to overheat and can lead to tire failure. Under-inflation also reduces fuel efficiency and tire tread life, and may affect the vehicle's handling and stopping ability.

Please note that the TPMS is not a substitute for proper tire maintenance, and it is the driver's responsibility to maintain correct tire pressure, even if under-inflation has not reached the level to trigger illumination of the TPMS low tire pressure telltale. ▶

WARNING

The traction grade assigned to this tire is based on straight-ahead braking traction tests, and does not include acceleration, cornering, hydroplaning or peak traction characteristics.

Your vehicle has also been equipped with a TPMS malfunction indicator to indicate when the system is not operating properly. The TPMS malfunction indicator is combined with the low tire pressure telltale. When the system detects a malfunction, the telltale will flash for approximately one minute and then remain continuously illuminated. This sequence will continue upon subsequent vehicle start-ups as long as the malfunction exists.

When the malfunction indicator is illuminated, the system may not be able to detect or signal low tire pressure as intended. TPMS malfunctions may occur for a variety of reasons, including the installation of replacement or alternate tires or wheels on the vehicle that prevent the TPMS from functioning properly. Always check the TPMS malfunction telltale after replacing one or more tires or wheels on your vehicle to ensure that the replacement or alternate tires and wheels allow the TPMS to continue to function properly.

If the tire pressure monitoring indicator appears

Applies to: vehicles with Tire Pressure Monitoring System indicator

The tire pressure indicator in the instrument cluster informs you if the tire pressure is too low or if there is a system malfunction.



Using the ABS sensors, the tire pressure monitoring system compares the tire tread circumference and vibration characteristics of the individual tires. If the pressure changes in one or more tires, this is indicated in the instrument cluster display with an indicator light  and a message. If only one tire is affected, the location of that tire will be indicated.

The tire pressures must be stored again each time you change the pressures (switching between partial and full load pressure) or after changing or replacing a tire on your vehicle \Rightarrow page 260. The tire pressure monitoring system only monitors the tire pressure you have stored. Refer to the tire pressure label for the recommended tire pressure for your vehicle \Rightarrow page 252, fig. 159.

Tire tread circumference and vibration characteristics can change and cause a tire pressure warning if:

- The tire pressure in one or more tires is too low
- The tires have structural damage
- The tire was replaced or the tire pressure was changed and it was not stored \Rightarrow page 260
- Tires that are only partially used are replaced with new tires

Indicator lights

If the  indicator light turns on, there is a loss of pressure in at least one tire. \Rightarrow  Check the tires and replace if necessary. Check and correct the pressures of all four tires and store the pressure again \Rightarrow page 260.

If you have not stored new tire pressures, but the indicator light  is blinking and an audio signal sounds, then drive to an authorized Audi dealer or authorized Audi Service Facility immediately to have the malfunction corrected.

TPMS Tire pressure: malfunction! See owner's manual

If **TPMS** appears after switching the ignition on or while driving and the  indicator light in the instrument cluster blinks for approximately one minute and then stays on, there is system malfunction. Try to store the correct tire pressures \Rightarrow page 260. In some cases, you must drive for several minutes after storing the pressures until the indicator light turns off. If the indicator light does turn off or turns on again after a short period of time, drive to an authorized Audi dealer or authorized Audi Service Facility immediately to have the malfunction corrected.



WARNING

- If the tire pressure indicator appears in the display, reduce your speed immediately and avoid any hard steering or braking maneuvers. Stop as soon as possible and check the tires and their pressure.
- The driver is responsible for maintaining the correct tire pressure. You must check the tire pressure regularly.

- Under certain conditions (such as a sporty driving style, winter conditions, or unpaved roads), the tire pressure monitoring system indicator may be delayed.

Tips

- The tire pressure monitoring system can also stop working when there is an ESC malfunction.
- Using snow chains may result in a system malfunction.
- The tire pressure monitoring system in your Audi was calibrated with “Audi Original Tires” ⇒ *page 248*. Audi recommends using these tires.

Storing tire pressures

Applies to: vehicles with Tire Pressure Monitoring System indicator

If the tire pressure changes or a tire is replaced, it must be confirmed in the system.

- ▶ Before storing the tire pressures, make sure the tire pressures of all four tires meet the specified values and are adapted to the load ⇒ *page 252*.
- ▶ Switch the ignition on.
- ▶ Applies to MMI: Select on the home screen: **VEHICLE > Settings & Service > Tire pressure monitoring > Store tire pressure > Yes, store now**.

Tips

Do not store the tire pressures if snow chains are installed.

Care and cleaning

General information

Regular, proper care helps to maintain your vehicle's value. It can also be a requirement when submitting warranty claims for corrosion damage and paint defects on the body.

The required cleaning and care products can be obtained from an authorized Audi dealer or authorized Service Facility. Read and follow the instructions for use on the packaging.

WARNING

- Using cleaning and care products incorrectly can be dangerous to your health.
- Always store cleaning and care products out of reach of children to reduce the risk of poisoning.

Car washes

The longer that deposits such as insects, bird droppings, tree sap or road salt remain on the vehicle, the more the surface can be damaged. High temperatures such as those caused by sunlight increase the damaging effect.

Before washing, rinse off heavy deposits with plenty of water.

Stubborn deposits such as bird droppings or tree sap are best removed with plenty of water and a microfiber cloth.

Also, wash the underside of your vehicle once road salt stops being used for the season.

Pressure washers

When washing your vehicle with a pressure washer, always follow the operating instructions provided with the pressure washer. This is especially important in regard to the pressure and spraying distance. Do not aim the spray directly at the seals on the side windows, doors, lids or the sunroof* or at tires, rubber hoses, insulating material, sensors* or camera lenses*. Maintain a distance of at least 16 inches (40 cm).

Do not direct the washer stream toward the wall mount clip*.

Do not remove snow and ice with a pressure washer.

Never use cone nozzles or high pressure nozzles.

The water temperature must not be above 140 °F (60 °C).

Automatic car wash

Spray off the vehicle before washing.

Make sure that the windows and roof* are closed and the windshield wipers are off. Make sure that the vehicle is still able to roll during the washing process in the car wash. Follow instructions from the car wash operator, especially if there are accessories attached to your vehicle.

If possible, use car washes that do not have brushes.

Washing by hand

Clean the vehicle starting from the top and working downward using a soft sponge or cleaning brush. Use solvent-free cleaning products.

Washing vehicles with matte finish paint by hand

To reduce the risk of damaging the paint when washing, first remove dust and large particles from your vehicle. Insects, grease spots, and fingerprints are best removed with a special cleaner for matte finish paint.

Apply the product using a microfiber cloth. To reduce the risk of damaging the paint surface, do not use too much pressure.

Rinse the vehicle thoroughly with water. Then clean using a neutral shampoo and a soft microfiber cloth.

Rinse the vehicle thoroughly again and let it air dry. Remove any water residue using a chamois.

WARNING

- To reduce the risk of accidents, only wash the vehicle when the ignition is off and follow the instructions from the car wash operator.

- To reduce the risk of cuts, protect yourself from sharp metal components when washing the underbody or the inside of the wheel housings.
- After washing the vehicle, the braking effect may be delayed due to moisture on the brake rotors or ice in the winter. This increases the risk of an accident. The brakes must be dried with a few careful brake applications.

Note

- If you wash the vehicle in an automatic car wash, you must fold the exterior mirrors in to reduce the risk of damage to the mirrors. Power folding exterior mirrors* must only be folded in and out using the power folding function.
- To reduce the risk of damage to the rims and tires, compare the width between the wheels on your vehicle with the distance between the guide rails in the car wash.
- To reduce the risk of damage, compare the height and width of your vehicle with the height and width of the inside of the car wash.
- Make sure there is sufficient ground clearance when driving into a car wash with a conveyor belt ⇒ *page 100*. There is risk of damage because the vehicle could come in contact with the guide rails.
- Using a pressure washer incorrectly can cause damage. Never direct a stream of wa-

ter directly onto electrical/electronic components when cleaning the front compartment. Such components can be seriously damaged by the entry of fluids and by pressure, and this can lead to component failure.

- To reduce the risk of paint damage, do not wash the vehicle in direct sunlight.
- To reduce the risk of damage, do not wash decorative decals* with a pressure washer.
- To reduce the risk of damage to the surface, do not use insect removing sponges, kitchen sponges, or similar items.
- When washing matte finish painted vehicle components:
 - To reduce the risk of damage to the surface, do not use polishing agents or hard wax.
 - Never use protective wax. It can destroy the matte finish effect.
 - Do not place any stickers or magnetic signs on vehicle components painted with matte finish paint. The paint could be damaged when the stickers or magnets are removed.

For the sake of the environment

Only wash the vehicle in facilities specially designed for that purpose. This will reduce the risk of dirty water contaminated with oil from entering the sewer system.

Cleaning and care information

When cleaning and caring for individual vehicle components, refer to the following tables. The information contained there is simply recommendations. For questions or for components

that are not listed, consult an authorized Audi dealer or authorized Audi Service Facility. Also follow the information found in ⇒ .

Exterior cleaning

Component	Situation	Solution
Windshield wiper blades	Deposits	Soft cloth with glass cleaner, ⇒ <i>page 57</i>
Headlights/ tail lights	Deposits	Soft sponge with a mild soap solution ^{a)}

Component	Situation	Solution
Sensors/ camera lenses	Deposits	Sensors: soft cloth with a solvent-free cleaning product Camera lenses: soft cloth with an alcohol-free cleaning solution
	Snow/ice	Hand brush/solvent-free de-icing spray
Wheels	Road salt	Water
	Brake dust	Acid-free special cleaning solution
Decorative parts and trim	Deposits	Mild soap solution ^{a)} , cleaning solution suitable for stainless steel, if necessary
Rubber seals	Deposits	Microfiber cloth with a mild soap solution ^{a)}
	Frost	Protect the seals on doors, covers, and lids from freezing using a suitable care product
Paint	Paint damage	Repair with touch-up paint
	Surface rust	Rust remover, then treat with hard wax; for questions, consult an authorized Audi dealer or authorized Audi Service Facility.
	Corrosion	Have it removed by an authorized Audi dealer or authorized Audi Service Facility.
	Water no longer beads on the surface of clean paint	Treat with hard wax (at least twice per year)
	No shine even though paint has been protected/paint looks poor	Treat with suitable polish; then apply paint protectant if the polish that was used does not contain any protectant
	Deposits such as insects, bird droppings, tree sap, and road salt	Dampen with water immediately and remove with a microfiber cloth
	Grease-based contaminants such as cosmetics or sunblock	Remove immediately with a mild soap solution ^{a)} and a soft cloth
Carbon components	Deposits	Clean the same way as painted parts ⇒ <i>page 261</i> ▶

Care and cleaning

Component	Situation	Solution
Decorative decals	Deposits	Soft sponge with a mild soap solution ^{a)}
	Deposits such as insects, bird droppings, tree sap, and road salt	Dampen with water immediately and remove with a micro-fiber cloth
	Grease-based contaminants such as cosmetics or sunblock	Remove immediately with a mild soap solution ^{a)} and a soft cloth
	Spilled fuel	Blot immediately with a soft cloth and then remove with a mild soap solution ^{a)} and a soft cloth
Audi e-tron charging system	Deposits	Soft, dry towel
Wall mount clip	Deposits	Soft towel with alcohol-free cleaning solution

^{a)} Mild soap solution: maximum two tablespoons of neutral soap in 1 quart (1 liter) of water

Interior cleaning

Component	Situation	Solution
Window glass	Deposits	Glass cleaner, then wipe dry
Decorative parts and trim	Deposits	Mild soap solution ^{a)}
Plastic parts	Deposits	Damp cloth
	Heavier deposits	Mild soap solution ^{a)} , detergent-free plastic cleaning solution, if necessary
Displays/instrument cluster	Deposits	Soft cloth with LCD cleaner; dust in the lower area of the instrument cluster can be removed using a soft brush.
Controls	Deposits	Soft brush, then a soft cloth with a mild soap solution ^{a)}
Safety belts	Deposits	Mild soap solution ^{a)} , allow to dry before letting them retract
Textiles, artificial leather, microfiber	Deposits adhering to the surface	Vacuum cleaner
	Water-based deposits such as coffee, tea, blood, etc.	Absorbent cloth and mild soap solution ^{a)}
	Oil-based deposits such as oil, make-up, etc.	Apply a mild soap solution ^{a)} , blot away the dissolved oil or dye, treat afterward with water, if necessary
	Certain types of deposits such as ink, nail polish, latex paint, shoe polish, etc.	Special stain remover, blot with absorbent material, treat afterward with mild soap solution, if necessary ^{a)}

Component	Situation	Solution
Natural leather	Fresh stains	Cotton cloth with a mild soap solution ^{a)}
	Water-based deposits such as coffee, tea, blood, etc.	Fresh stains: absorbent cloth dried stains: stain remover suitable for leather
	Oil-based deposits such as oil, make-up, etc.	Fresh stains: absorbent cloth and stain remover suitable for leather dried stains: oil cleaning spray
	Certain types of deposits such as ink, nail polish, latex paint, shoe polish, etc.	Spot remover suitable for leather
	Care	Regularly apply conditioning cream that protects from light and penetrates into the material. Use special colored conditioning cream, if necessary.
Carbon components	Deposits	Clean the same way as plastic components

^{a)} Mild soap solution: maximum two tablespoons of neutral soap in 1 quart (1 liter) of water

WARNING

The windshield must not be treated with water-repelling windshield coating agents. Under unfavorable conditions, such as wetness, darkness, and when the sun is low, these coatings can cause increased glare, which increases the risk of an accident. They can also cause wiper blade chatter.

WARNING

- Never immerse the Audi e-tron charging system and connectors in water.
- The Audi e-tron charging system must only be cleaned when the control unit is completely disconnected from the power supply and from the vehicle.

Note

- **Headlights and tail lights**
 - Never clean the headlights or tail lights with a dry cloth or sponge because the lights could be damaged.
 - Do not use any cleaning products that contain alcohol, because they could cause cracks to form.
- **Wheels**

- Never use any paint polish or other abrasive materials.
- Damage to the protective layer on the rims, such as stone chips or scratches, must be repaired immediately.

– **Camera lenses**

- Never use warm or hot water to remove snow or ice from the camera lens. This could cause the lens to crack.
- Never use abrasive cleaning materials or alcohol to clean the camera lens. This could cause scratches and cracks.

– **Door windows**

- Remove snow and ice on windows and exterior mirrors with a plastic scraper. To reduce the risk of scratches, move the scraper only in one direction and not back and forth.
- Never remove snow or ice from door windows and mirrors using warm or hot water because this could cause cracks to form.
- To reduce the risk of damage to the rear window defogger, do not apply any stickers on the heating wires on the inside of the window.

– **Decorative parts and trim**

- Never use chrome care or cleaning products.
- **Rubber seals**
 - There is a risk of damage if chemical cleaning solutions or solvents are used.
- **Paint**
 - To reduce the risk of scratches, the vehicle must be free of dirt and dust before polishing or waxing.
 - To prevent paint damage, do not polish or wax the vehicle in direct sunlight.
 - To reduce the risk of paint damage, do not polish away rust spots.
 - Remove cosmetics and sunscreen immediately because they could damage the paint.
- **Decorative decals**
 - Do not clean decorative decals with a pressure washer, because the decals could loosen.
 - To reduce the risk of damage, do not use any rough powder or abrasive cleaning products.
 - To reduce the risk of damage, do not polish decorative decals.
 - Due to the risk of damage, do not use an ice scraper to remove snow and ice on windows with decorative decals on them.
- **Displays and instrument cluster**
 - Make sure that the display and instrument cluster are switched off and have cooled down before cleaning. To switch off the center display, select on the MMI home screen: **SETTINGS > Display & Brightness > MMI > Screen cleaning**.
 - Displays, the instrument cluster, and the trim surrounding it must not be cleaned with dry cleaning methods because they could become scratched.
 - Make sure no fluids enter the spaces between the instrument cluster and the trim, because that could cause damage.
- **Controls**
 - Make sure that no fluids enter the controls, because this could cause damage.
- **Safety belts**
 - Do not remove the safety belts to clean them.
 - Never clean safety belts or their components with chemicals or with corrosive fluids or solvents and never allow sharp objects to come into contact with the safety belts. This could cause damage to the belt webbing.
 - If there is damage to the webbing, the connections, the retractors, or the buckles, have them replaced by an authorized Audi dealer or authorized Audi Service Facility.
- **Textiles/artificial leather/microfiber**
 - Never treat artificial leather or microfiber with leather care products, solvents, floor polish, shoe polish, spot remover, or similar products.
 - Have a cleaning specialist remove stubborn stains to reduce the risk of damage.
 - Never use steam cleaners, brushes, hard sponges, etc. when cleaning.
 - Do not turn on the seat heating* to dry the seat.
 - Objects with sharp edges, such as zippers or rivets on clothing or belts, can cause damage to the surface.
 - Open hook and loop fasteners, for example on clothing, can damage seat covers. Make sure hook and loop fasteners are closed.
- **Natural leather**
 - Never treat leather with solvents, floor polish, shoe polish, spot remover or similar products.
 - Objects with sharp edges, such as zippers or rivets on clothing or belts, can cause damage to the surface.
 - Never use steam cleaners, brushes, hard sponges, etc. when cleaning.
 - Do not turn on the seat heating* to dry the seat.
 - To help prevent the leather from fading, do not leave the vehicle in direct sunlight for long periods of time. If leaving the vehicle parked for long periods of time, you should cover the leather to protect it from direct sunlight.

– Wall mount clip

- Do not use any abrasive cleaning products or any that contain alcohol, because these increase the risk of discoloration.

i Tips

- Insects are easier to remove from paint that has been freshly waxed.
- Regular waxing can prevent rust spots from forming.
- Decorative decals can age due to environmental conditions, which can result in damage such as brittleness. The color may fade if exposed to excessive sunlight.

Taking your vehicle out of service

If you would like to take your vehicle out of service for a long period of time, contact an authorized Audi dealer or authorized Audi Service Facility. You can obtain information about the steps to complete depending on the conditions for taking the vehicle out of service (duration, location, etc.).

Emergency assistance

General information

- ▶ Park the vehicle as far as possible from moving traffic in the event of a breakdown. In the event of a flat tire, park the vehicle on a level surface. If you are on a steep hill, be especially careful.
- ▶ Set the parking brake.
- ▶ Switch the emergency flashers on.
- ▶ Have all passengers exit the vehicle. They should move to a safe place, for example behind a guard rail.

WARNING

Follow the steps given above. This is for your own protection and for the safety of other road users.

Equipment

Vehicle tool kit/tire mobility kit

Applies to: vehicles with vehicle tool kit and tire mobility kit



Fig. 160 Luggage compartment: cargo floor*

The vehicle tool kit, tire mobility kit, and compressor are located in the luggage compartment under the cargo floor*.

- ▶ Lift the cargo floor* using the handle ⇒ *fig. 160*.
- ▶ Fold the cargo floor mat up using the loop in order to open the compartment beneath.

The tire mobility kit and the compressor are located in the storage bag.

Tire mobility kit

Preparation

Applies to: vehicles with tire mobility kit

- ▶ Read and follow the important safety precautions ⇒ *page 268*.
- ▶ Set the parking brake.
- ▶ Check if a repair with the tire mobility kit is possible ⇒ *page 268*.

Using the tire mobility kit

Applies to: vehicles with tire mobility kit



Fig. 161 Tire: tire damage that cannot be repaired

The tire repair is only meant for temporary use. Change the damaged tire as soon as possible ⇒ .

If the tire is pierced by an object such as a nail, do not remove the object from the tire.

The tire mobility kit can be used at temperatures as low as -4 °F (-20 °C).

The tire mobility kit must not be used:

- If the tire has cuts or punctures that are larger than 0.16 inch (4 mm) (1) ⇒ *fig. 161*
- If the rim is damaged (2)
- If you have driven with very low tire pressure or without air in the tire (3)

See an authorized Audi dealer or authorized Audi Service Facility for assistance in these cases.

WARNING

- Please note that the tire mobility kit cannot be used in all situations, and that it may only be used temporarily.
- The tire sealant must not come in contact with skin, eyes, or clothing.

- If tire sealant comes into contact with your eyes or your skin, thoroughly rinse the affected area immediately with clean water.
- Do not inhale the fumes.
- If you swallow any of the tire sealant, thoroughly rinse your mouth immediately and drink a lot of water. Do not induce vomiting. Seek medical attention immediately.
- Change your clothing immediately if it comes into contact with tire sealant.
- Seek medical attention immediately if an allergic reaction occurs.
- Keep the tire sealant away from children.

For the sake of the environment

 Batteries and electrical/electronic devices must be disposed of in an environmentally safe manner ⇒ *page 291, Disposal instructions.*

Tips

- If sealant leaks, allow it to dry in place. You can then peel it off like a sticker.
- Note the expiration date on the sealant bottle. Replace the tire sealant at an authorized Audi dealer or authorized Audi Service Facility.
- Radio reception can be interrupted when operating the compressor.
- Follow the legal regulations that are applicable in the country where you are operating the vehicle.

Repairing tires

Applies to: vehicles with tire mobility kit

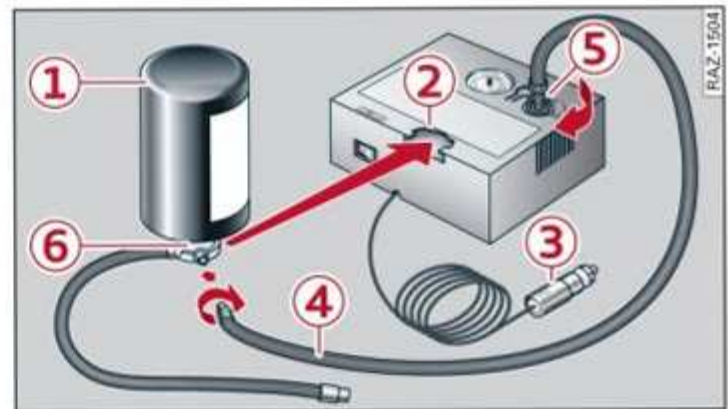

Fig. 162 Components of the tire mobility kit

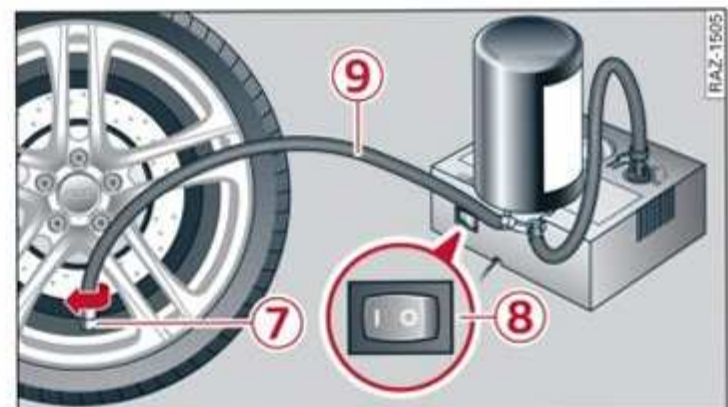

Fig. 163 Tire mobility kit connection



Requirement: the tire mobility kit must be laid out and ready for use ⇒ *page 268.*

Setting up the tire mobility kit

- ▶ Remove the “max. 50 mph (max. 80 km/h)” sticker from the socket of the compressor¹⁾.
- ▶ Take the connector ③ and pressure hose ④ from the bottom of the housing.
- ▶ Install one end of the pressure hose ④ all the way into the socket ⑤ of the compressor by turning it clockwise. Install the other end on the flange ⑥ of the tire sealant bottle ①.
- ▶ Insert the sealant bottle with the flange at the bottom into the opening ② on the compressor.
- ▶ Remove the valve cap from the faulty tire.
- ▶ Connect the filler hose ⑨ to the valve ⑦ ⇒ *fig. 163.*
- ▶ Connect the plug ③ ⇒ *fig. 162* to an outlet in the vehicle.
- ▶ Switch the ignition on.

¹⁾ The compressor may look different. However, the way it is operated is generally the same.

Inflating a tire

- ▶ Move the switch  ⇒ *fig. 163* on the compressor into position I.
- ▶ Inflate the tire to between 29 psi (200 kPa) and 36 psi (250 kPa) and read the pressure on the gauge.
- ▶ If this tire pressure is not reached, remove the filler hose. Drive slowly approximately 33 feet (10 m) forward or in reverse so that the sealant can be distributed in the tire. Inflate the tire again ⇒ .

WARNING

- Read and follow the manufacturer's safety precautions on the compressor and in the instructions on the bottle of sealant.
- If a tire pressure of 29 psi (200 kPa) cannot be reached after inflating for 10 minutes, then the tire is too severely damaged. Do not continue driving.
- If the tire cannot be repaired with the tire sealant, see an authorized Audi dealer or authorized Audi Service Facility for assistance.

Tips

Do not operate the compressor for more than ten minutes continuously, or it can overheat. Once the compressor has cooled, you can continue to use it.

Completing

Applies to: vehicles with tire mobility kit

- ▶ Affix the sticker that says "max. 50 mph (max. 80 km/h)" that is provided with the tire mobility kit within your field of vision.
- ▶ Stop the vehicle after driving for about 10 minutes and check the tire pressure.
- ▶ If the tire pressure is lower than 19 psi (130 kPa), then the tire is too severely damaged. Do not continue driving.

WARNING

- Pay attention to the following after repairing the tire:
- Do not drive faster than 50 mph (80 km/h).

- Avoid hard acceleration or braking and driving fast around curves.
- The vehicle may become more difficult to control.
- If the tire is too severely damaged, see an authorized Audi dealer or authorized Audi Service Facility for assistance.

For the sake of the environment

You can give the used tire sealant bottle to an authorized Audi dealer or authorized Audi Service Facility for disposal.

Tips

Remember to obtain a new bottle of sealant from an authorized Audi dealer or authorized Audi Service Facility after repairing a tire.

Changing a tire

Preparation

You must complete the preparation before changing a tire.

You should only perform the following steps if you have the necessary technical knowledge and tools. Audi recommends having the tires changed by an authorized Audi dealer or authorized Audi Service Facility.

Commercially available tools, such as a vehicle jack and a wheel wrench, are needed to change the tires. Have these ready when starting the procedure.

- ▶ Read and follow the important safety precautions ⇒ *page 268*.
- ▶ Set the parking brake.
- ▶ When towing a trailer: disconnect the trailer from your vehicle.
- ▶ Switch the ignition off.

WARNING

When using a vehicle jack*, the vehicle must also be secured to prevent it from rolling. Use suitable objects to block the front and back of the wheel that is diagonal from the wheel with the flat tire.

Removing the caps



Fig. 164 Wheel: wheel bolts with caps

- ▶ Slide the plastic clip from the vehicle tool kit onto the cap until it engages ⇒ *fig. 164*.
- ▶ Remove the cap with the plastic clip.

Loosening the wheel bolts

- ▶ Slide the wheel wrench* onto the wheel bolt as far as it will go.
- ▶ Turn the wheel bolt approximately one turn to the left to loosen it.

! WARNING

To reduce the risk of an accident, only loosen the wheel bolts gently one turn before raising the vehicle with the vehicle jack*.

Raising the vehicle



Fig. 165 Sill panels: markings

- ▶ Place the vehicle jack* on a firm surface. Use a flat, stable support if necessary. On a slippery surface such as tile, you should use a non-slip pad such as a rubber mat ⇒ **!**.
- ▶ Find the marking on the sill that is closest to the tire that will be changed ⇒ *fig. 165*. Behind

the marking, there is a lifting point on the side sill for the vehicle jack*.

- ▶ Lift the vehicle using the vehicle jack* until the wheel lifts off the ground slightly.

! WARNING

- To reduce the risk of injury, make sure no one is in the vehicle before raising it.
- Make sure the vehicle jack* is stable. The risk of injury is increased when the ground is slippery or soft, because the vehicle jack could slide or sink.
- Position the vehicle jack* only at the designated mounting points on the side sill and align the jack. Otherwise, the vehicle jack* could slip and cause an injury if it does not have sufficient hold on the vehicle.
- To reduce the risk of an accident, never start the drive system when the vehicle is raised.
- To reduce the risk of injury, no work should be performed under the vehicle while it is raised.

! Note

Do not lift the vehicle by the sill. Position the vehicle jack only at the designated mounting points on the side sill. Otherwise, your vehicle could be damaged.

Removing and installing a wheel

Removing a wheel

- ▶ Remove the loosened wheel bolts completely using the wheel wrench* and place them on a clean surface.
- ▶ Remove the wheel ⇒ **!**.

Installing a wheel

Read the directions on ⇒ *page 272* when installing unidirectional tires.

- ▶ Install the wheel.
- ▶ Install the wheel bolts and tighten them lightly.
- ▶ Carefully lower the vehicle using the vehicle jack*.
- ▶ Tighten the wheel bolts in a diagonal pattern using the wheel wrench*.

The wheel bolts must be clean and loosen and tighten easily. Check the contact surfaces for the wheel and hub. Contaminants on these surfaces must be removed before installing the wheel.

WARNING

Read and follow the important information and notes under ⇨ *page 248*.

Note

When removing or installing the wheel, the rim could hit the brake rotor and damage the rotor. Work carefully and have a second person help you.

Unidirectional tires

A unidirectional tire profile is identified by arrows on the tire sidewall that point in the running direction. You must always maintain the specified running direction. This is necessary to ensure the tire's optimal performance in regard to adhesion, running noise, and friction, and to reduce the risk of hydroplaning.

To benefit fully from the advantages of the unidirectional tire design, you should replace faulty tires as soon as possible and restore the correct running direction on all of the tires.

Finishing

- ▶ Reinstall any covers on the wheel bolts that were removed.
- ▶ Store the replaced tire securely in the luggage compartment ⇨ *page 80*.
- ▶ Check the tire pressure on the installed wheel as soon as possible.
- ▶ Correct the tire pressure and store it in the MMI ⇨ *page 260*.
- ▶ The wheel bolts must be tightened to 90 ft lbs (120 Nm). Have them checked as soon as possible with a torque wrench. Drive carefully until then.
- ▶ Have the faulty wheel replaced as soon as possible.

Jump starting

Preparation

You should only perform the following steps if you have the necessary technical knowledge and tools.

If drive ready mode cannot be established because the 12 volt vehicle battery is drained, you can use another vehicle to supply energy to the 12 volt vehicle battery. Jump start cables are needed to do this.

Both vehicle batteries must have 12 V nominal voltage. The voltage capacity (Ah) of the vehicle battery that is giving power must not be less than the capacity of the drained vehicle battery.

Jump start cable

Only use a jump start cable with a large enough diameter. Note the manufacturer's specifications.

Only use a jump start cable with insulated terminal clamps.

Positive cable - usually red.

Negative cable - usually black.

WARNING

- A drained battery can freeze at temperatures around 32 °F (0 °C). If the vehicle battery is frozen, it must be thawed before connecting the jump start cables. If it is not, the risk of an explosion and chemical burns increases. After supplying energy from an external source, drive to an authorized Audi dealer or authorized Audi Service Facility immediately to have the vehicle battery checked.
- Read the warnings when working in the front compartment ⇨ *page 229*.
- Handling the jump start cables incorrectly may cause the vehicle battery to explode and lead to serious injuries.

! Note

- Jump start cables can cause considerable damage to the vehicle electrical system if they are connected incorrectly.
- You must **not** give a jump start with your vehicle. This could cause significant damage to the electrical system in your vehicle.

i Tips

- There must be no contact between the vehicles, or else voltage could flow when connecting the positive terminal and drain the vehicle battery of the vehicle providing the jump start.
- The drained vehicle battery must be connected correctly to the electrical system.
- Switch off electrical equipment that is not needed.

Jump starting

Both jump start cables must be connected in the correct order.



Fig. 166 Front compartment: connectors for jump start cables or a charger

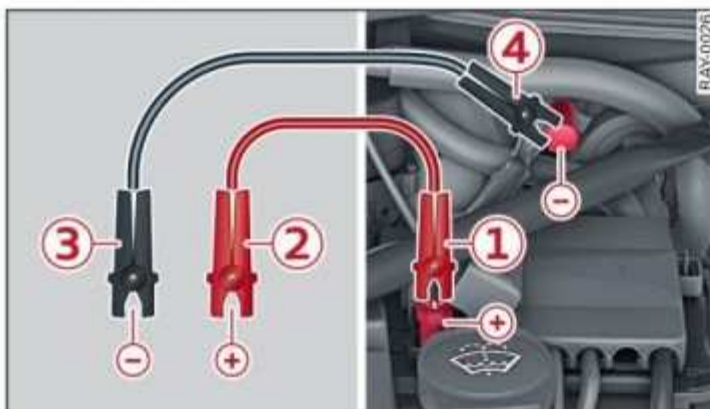

Fig. 167 Connecting the jump start cables

The jump start cables are located in the front compartment.

Follow the information about the vehicle battery ⇒ page 236.

Connecting the positive cable (red) to the positive terminal

- ▶ Open the cover on the positive terminal ⇒ fig. 166.
- 1. Attach one end of the positive cable (red) to the jump-start pin ① ⇒ fig. 167 on your vehicle.
- 2. Attach the other end of the positive cable (red) to the positive terminal ② on the power source.

Connecting the negative cable (black) to the negative terminal

- 3. Attach one end of the negative cable (black) to the negative terminal ③ on the power source.
- 4. Attach the other end of the negative cable (black) to the jump-start pin ④ on the vehicle.

Establishing drive ready mode

- ▶ Start the engine in the vehicle giving the charge and let it run at idle.
- ▶ Establish drive ready mode in your vehicle with the drained vehicle battery.
- ▶ If drive ready mode cannot be established, stop the procedure and try again after approximately one minute.
- ▶ Remove the cables in reverse order of the way they were installed.
- ▶ Close the cover on the positive terminal.
- ▶ Immediately visit an authorized Audi dealer or authorized Audi Service Facility to have the vehicle battery checked.

! WARNING

- Never connect the jump start cable directly to your vehicle battery. Only use the connections in the front compartment.
- Do not touch the non-insulated parts of the terminal clamps. The cable must also not come into contact with vehicle components that conduct electricity when it is connected to the positive vehicle battery terminal. This can cause a short circuit.

- The plugs on the battery cells must not be opened.
- Keep ignition sources (such as open flames, burning cigarettes, etc.) away from the vehicle batteries to reduce the risk of an explosion.
- Route the jump start cables so they cannot become caught in the moving parts in the other vehicle's front compartment.

Note

Please note that the connecting process previously described for the jump start cables is intended for when your vehicle is being jump started.

Tips

Make sure that the connected jump start cables have sufficient contact with metal.

Towing

General information

You should only perform the following steps if you have the necessary technical knowledge and tools.

Towing requires a certain amount of practice. Audi recommends contacting a towing company to have the vehicle transported.

You should only have your vehicle towed by another vehicle when disabled in exceptional circumstances. Inexperienced persons should not tow a vehicle.

Notes on towing

- The maximum permitted towing speed is 30 mph (50 km/h).
- The maximum permitted towing distance is 30 miles (50 km).

Additional information on towing with a tow truck

The vehicle must be transported with both axles on a tow truck or a special transporter. Contact a towing service.

Tow bar and towing cable

The vehicle can be towed with a tow bar or towing cable. Both persons should be familiar with the special considerations when towing, especially when using a towing cable.



Always make sure the traction force does not exceed the permitted level and there are no shock loading conditions. There is always the risk of the coupling becoming overloaded when driving off-road.

For the most safety and security, drive with a tow bar. You should use a towing cable only if a tow bar is not available. Use a towing cable made of synthetic elastic cable similar elastic material.

WARNING

- Towing highly increases the risk of an accident, for example from colliding with the towing vehicle.
- To reduce the risk of an accident, do not allow anyone to remain inside the vehicle when it is being transported by a tow truck or a special transporter.
- Never secure the tow bar or towing cable to parts of the vehicle's axles or suspension. These could be damaged, leading to accidents and severe injuries.

Note

- If the  indicator light turns on and the message **Vehicle must not be towed! See owner's manual** appears, then the vehicle must not be towed. The drive system can be severely damaged.
- If the  indicator light turns on, there is a fault in the cooling circuit. The vehicle must not be towed. The drive system can be severely damaged.
- If normal towing is not possible, for example if the transmission is faulty or if the towing distance is greater than 30 miles (50 km), then transport the vehicle on a special carrier.
- Towing must not be used to charge the high-voltage battery (recuperation), because this could result in major damages to the tow vehicle or the vehicle being towed.

- The vehicle must not be tow started for technical reasons.

i Tips

- The vehicle is not designed to tow other vehicles.
- Switch Audi pre sense* off ⇒ *page 156* when loading the vehicle onto a vehicle carrier, train, ship, or other type of transportation, or when towing the vehicle. This can prevent an undesired intervention from the pre sense* system.
- Do not wrap any chains or cables around the brake lines.
- Follow the local legal regulations for towing.

Towing eye for professional towing services

Applies to: vehicles with towing eye for professional towing services



Fig. 168 Rear of the vehicle: towing eye for professional towing services

A towing eye for professional towing services is provided for pulling the vehicle onto tow trucks. It is located at the rear of your vehicle on the driver's side below the bumper cover.

The towing eye is only designed for a towing cable or a towing chain.

! WARNING

- Any attempt to tow another vehicle by the towing eye for professional towing services may damage the vehicle or lead to an accident causing serious injury or loss of life.
- The towing eye for professional towing services must only be used to pull your own vehicle onto a tow truck.

- Never attempt to tow another vehicle using the towing eye for professional towing services.

Towing

Read and follow the important information under ⇒ *page 274*.

Preparations

- ▶ Only secure the towing cable or tow bar at the designated towing loops ⇒ *page 276*, ⇒ *page 276*.
- ▶ Make sure the towing cable is not twisted. Otherwise it could disconnect from the towing loop while towing.
- ▶ Switch the emergency flashers on in both vehicles ⇒ *page 52*. However, do not do this if it prohibited by law.

Towing vehicle (front)

- ▶ Only start to drive when the towing cable is taut.
- ▶ Press the brake pedal very carefully.
- ▶ Avoid sudden braking or driving maneuvers.

Vehicle being towed (rear)

- ▶ Make sure the ignition is switched on so that the steering wheel is not locked and so that you can use the turn signals, the horn, and the windshield wipers if needed ⇒ **!**.
- ▶ Switching it off before the vehicle has stopped may impair the function of the brake booster and power steering. You would then need to use more force to steer and brake the vehicle.
- ▶ Release the parking brake ⇒ *page 97*.
- ▶ Select the "N" selector lever position.
- ▶ Make sure the towing cable is always taut.

! WARNING

- Never tow a vehicle using a tow bar or towing cable if the vehicle does not have electrical power.
- If the vehicle loses power while it is being towed, stop towing the vehicle immediately and consult an authorized Audi dealer or qualified repair facility.

- In an emergency situation, the vehicle can still be towed or pulled on its own wheels until it can be transported by a recovery vehicle, even if the  indicator light is on and the corresponding message has appeared. However, the speed must not be faster than a walking pace and the distance must not exceed 328 feet (100 m). In this case, you may experience vibrations in the drive system and blocking of the rear wheels, especially in icy or wet road conditions. Blocked wheels can reduce steering ability and lead to accidents and severe injuries.

Front towing loop

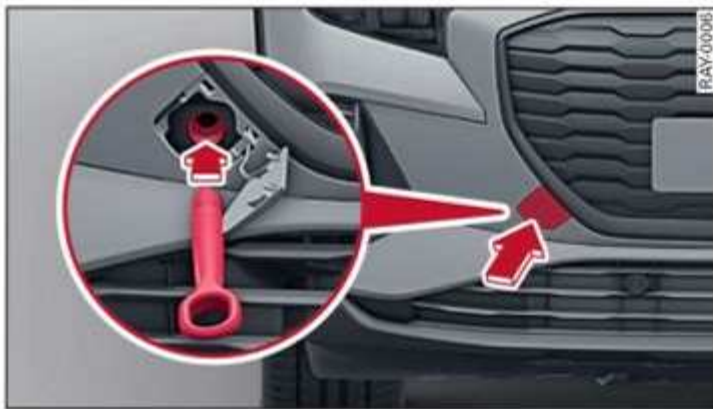

Fig. 169 Front bumper: installing the towing loop

The threaded opening for the towing loop is located on the right side of the front bumper.

- ▶ Remove the towing loop from the vehicle tool kit ⇒ *page 268*.
- ▶ Press the cap inward with brief, strong pressure ⇒ *fig. 169*. The cap will loosen from the bumper.
- ▶ Tighten the towing eye as far as it will go into the mount. Use a suitable object to tighten the towing eye completely and securely in the mount.
- ▶ After using, place the towing loop back in the vehicle tool kit.

WARNING

If the towing loop is not tightened all the way when installing, the threads may be pulled out when towing the vehicle and result in an accident.

Tips

Depending on the model, the shape of the cap can vary.

Rear towing loop

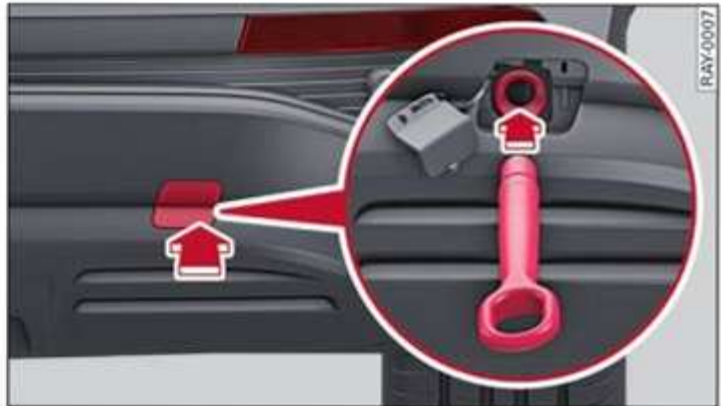

Fig. 170 Rear bumper: installing the towing loop

Vehicles with a towing loop

On vehicles without a factory-installed trailer hitch*, the towing loop threads are located on the right rear side of the bumper.

- ▶ Remove the towing loop from the vehicle tool kit ⇒ *page 268*.
- ▶ Press the cap inward with brief, strong pressure ⇒ *fig. 170*. The cap will loosen from the bumper.
- ▶ Tighten the towing eye as far as it will go into the mount. Use a suitable object to tighten the towing eye completely and securely in the mount.
- ▶ After using, place the towing loop back in the vehicle tool kit.

Vehicles with a trailer hitch*

- ▶ Attach the tow bar or the towing cable to the trailer hitch.

Vehicles with a factory-installed trailer hitch* are **not** equipped with towing loop threads at the rear.

WARNING

If the towing loop is not tightened all the way when installing, the threads may be pulled out when towing the vehicle and result in an accident.

! Note

To reduce the risk of damaging the trailer hitch*, only use suitable tow bars that are compatible with it. If a tow bar is not available, you can use a towing cable.

i Tips

Depending on the model, the shape of the cap can vary.

Fuses and bulbs

Fuses

Replacing fuses



Fig. 171 Left side of the cockpit: cover (left-hand drive) ① or cover in the glove compartment (right-hand drive) ②



Fig. 172 Left side of the front compartment: fuse panel cover ③

Fuses are installed in various locations in your vehicle. The following information only lists fuses that you can change yourself. To have other fuses changed, contact an authorized Audi dealer or authorized Audi Service Facility. The following table does not list fuse locations that are not used.

A fuse that has blown will have metal strips that have burned through.

Depending on vehicle equipment, the fuses may be located on the left side of the cockpit, behind a cover (left-hand drive) ①, or behind a cover in the glove compartment (right-hand drive) ②. Additional fuses are located under a cover on the left side of the front compartment ③.

- ▶ Switch the ignition and all electrical equipment off.
- ▶ Check the table that follows to see which fuse belongs to the affected equipment.
- ▶ Remove the appropriate cover.
- ▶ Remove the clip from the fuse panel in the front compartment ③.
- ▶ Remove the fuse using the clip.
- ▶ Replace the blown fuse only with a fuse that has the same amp rating.
- ▶ Install the cover.

Fuse color identification

Color	Current rating in amps
Black	1
Gray	2
Purple	3
Pink	4
Light brown	5
Brown	7.5
Red (narrow)	10
Light blue	15
Yellow	20
White or transparent	25
Light green	30
Teal	35
Orange	40
Red (wide)	50

WARNING

Do not repair fuses and never replace a blown fuse with one that has a higher amp rating. This can cause damage to the electrical system and increases the risk of fire.

Note

If a new fuse burns out again shortly after you have installed it, have the electrical system checked as soon as possible by an authorized Audi dealer or authorized Audi Service Facility.

Tips

Some of the equipment listed in the following tables applies only to certain model versions or certain optional equipment.

Cockpit fuse assignment

Fig. 173 Left side of cockpit: fuse assignment

No.	Equipment
2	Airbag control module
3	Trailer hitch
4	Driver assistance systems front camera
5	Vehicle electrical system control module, left tail light
6	Vehicle electrical system control module, interior lighting, ambient lighting
7	Air conditioning, seat heating
8	Panoramic glass roof
9	Left/right front door control module, left rear

No.	Equipment
10	Left front lumbar support
11	Trailer hitch
13	Vehicle electrical system control module, central locking, windshield washer system
14	Sound system
16	Power supply for measuring lead set
17	Parking aid, side assist, exterior mirrors
18	Steering column lock, convenience access and start authorization control module, anti-theft alarm, exterior sound generator
19	Instrument cluster, emergency call and communication control module
20	Audi phone box, USB connection, Audi connect apps control module
21	Camera systems
22	Drive system control module
23	Internet access control module
25	Driver's side safety belt tensioner
26	Left/right front door control module, right rear
27	Passenger's side safety belt tensioner
28	High-voltage battery emergency cut-off point, high-voltage charging system
29	Trailer hitch
30	Infotainment system
31	Trailer hitch
32	Vehicle electrical system control module, right tail light
33	Lumbar support
34	Climate control system - controls
36	Climate control system blower
37	Luggage compartment lid control module
39	Steering column electronics
40	Anti-theft alarm system
41	Diagnostic interface
42	Selector lever
43	Interior temperature sensor, air quality sensor, climate control system controls, rear window defogger

No.	Equipment
44	Light/rain/humidity sensor, interior lighting, roof module, anti-theft alarm system, diagnostic connection, light switch, driving and convenience functions
45	Steering column electronics
46	Volume control, center display, head-up display
47	Suspension control
48	USB connection
52	12 volt socket
59	Rearview mirror, 12 volt socket
60	Power supply for measuring lead set, diagnostic connection
61	Electric drive system
66	Rear window wiper
67	Rear window defogger

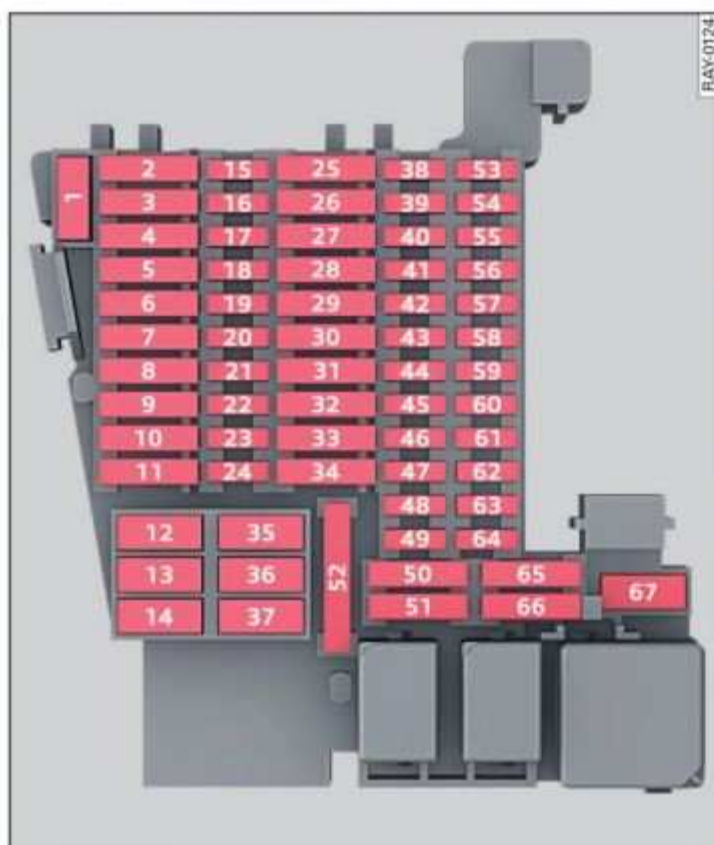
No.	Equipment
2	Anti-Lock Braking System (ABS), Electronic Stabilization Control (ESC), drive system, electromechanical steering
3	Electric drive system, high-voltage charger
4	Left headlight
5	Right headlight
6	Adaptive cruise assist
9	Horn
10	Windshield wipers
11	Relay, compressor and other climate control system components, climate control system - rear controls, air quality sensor, ionizer
12	Exterior sound generator
13	Anti-lock braking system (ABS), Electronic Stabilization Control (ESC)
15	Anti-lock braking system (ABS), Electronic Stabilization Control (ESC)
16	Engine cooling
17	Windshield defroster
18	Windshield defroster
23	Drive system control module
24	Engine cooling
25	Thermal management, high-voltage heating
26	High-voltage heating coolant pump, air intake (adjustable)
32	Brake system pressure reservoir

Fuse assignment - front compartment

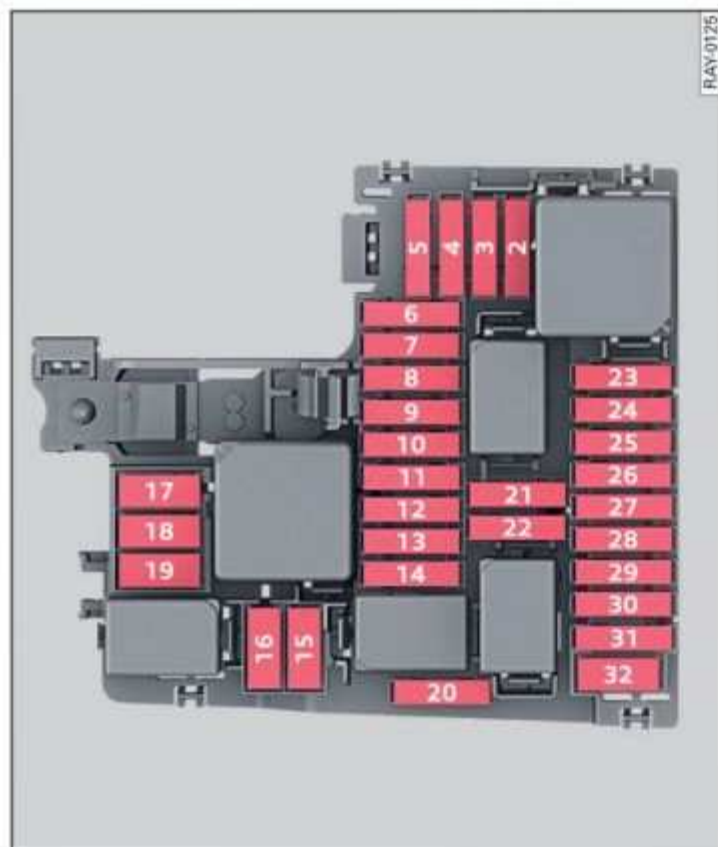

Fig. 174 Left front compartment: fuse assignment

Bulbs

Note

Your vehicle is equipped with maintenance-free headlights and tail lights. However, if a light bulb needs to be replaced, please contact an authorized Audi dealer or authorized Audi Service Facility.

Data privacy

Privacy notice

You can find information about responsibility for data privacy in the MMI.

Applies to: MMI: Select on the home screen: **SETTINGS > General > Legal notes > About Audi connect.**

Image recording

Surrounding area monitoring

Applies to: vehicles with surrounding area monitoring

The functionality of the park assist plus requires detecting and evaluating the vehicle's path. This is done by cameras installed permanently on the vehicle that detect objects in the vehicle's surroundings (such as obstacles or guard rails). The live images from the cameras are transmitted to the applicable control module.

The camera images are transferred to the responsible control module for processing and may be stored, depending on vehicle equipment. The control module analyzes the current camera image using image evaluation software. This image evaluation software detects anonymized technical measurements, such as distances to objects. The control module evaluates these technical measurements and makes it possible for the assist systems to control the vehicle as needed.

Data memories

Vehicle control modules



Fig. 175 Driver's side footwell: connection port for the On Board Diagnostic System (OBD)

Your vehicle is equipped with electronic control modules for various vehicle systems such as the airbags. These vehicle control modules store data while driving normally that is required by an authorized Audi dealer or authorized Audi Service Facility for diagnosis and repair purposes. Only certain types of data are recorded for a very short period of time if a control module has detected a system event. No noises, conversations, or images will be recorded in the vehicle.

The data may include information such as the vehicle speed, the direction of travel, and information about the brake system, or also the behavior of the restraint system in the event of an accident. The stored data can be exported and downloaded with special devices, which must be connected directly to the vehicle.

On Board Diagnostic System (OBD)

There is a diagnostic connector socket in the driver's side footwell to read out the various control modules and the event data recorder. Data regarding the function and condition of the electronic control modules is stored in the event memory. Only have an authorized Audi dealer or authorized Audi Service Facility read out and delete the event memory.

WARNING

- Incorrect use of the connection port for the On Board Diagnostic System can cause malfunctions, which can then result in accidents and serious injuries.
- Only allow an authorized Audi dealer or authorized Audi Service Facility to read out the motor data.

Crash data recorder

Event Data Recorder

This vehicle is equipped with an Event Data Recorder (EDR). The main purpose of an EDR is to record, in certain crash or near crash-like situations, such as an airbag deployment or hitting a road obstacle, data that will assist in understanding how a vehicle's system performed. The EDR is designed to record data related to vehicle dynamics and safety systems for a short period of ▶

time, typically 30 seconds or less. The EDR in this vehicle is designed to record such data as:

- How various systems in your vehicle were operating;
- Whether or not the driver and passenger safety belts were buckled/fastened;
- How far (if at all) the driver was depressing the accelerator and/or brake pedal; and,
- How fast the vehicle was traveling.

These data can help provide a better understanding of the circumstances in which crashes and injuries occur. NOTE: EDR data are recorded by your vehicle only if a non-trivial crash situation occurs; no data are recorded by the EDR under normal driving conditions and no personal data (e.g. name, gender, age, and crash location) are recorded. However, other parties, such as law enforcement, could combine the EDR data with the type of personally identifying data routinely acquired during a crash investigation.

To read data recorded by an EDR, special equipment is required, and access to the vehicle or the EDR is needed. In addition to the vehicle manufacturer, other parties, such as law enforcement, that have the special equipment, can read the information if they have access to the vehicle or the EDR.

Assist system monitor

This vehicle is equipped with an Assist System Monitor (ASM). The ASM collects data that is not stored by the EDR in the event of an accident. The main task of the ASM is to make it possible to understand the role and the behavior of the assist systems in these accident situations. In addition to the data that the EDR stores, the ASM records data related to the assist systems starting several seconds before the accident or near-accident. The data collected by ASM depends on the equipment and may include the following information: status information of the assist systems (for example, if they are switched on or off, system events, etc.), control interventions (for example, by ESC, ABS, Audi pre sense, etc.), and assist system settings (such as speed settings).

Special devices and access to the vehicle or to the ASM are necessary in order to read the data from

the ASM memory. In addition to the vehicle manufacturer, third parties such as law enforcement authorities can also read and analyze the stored data if they have access to the vehicle or to the ASM.

Data usage

Audi can read out the information stored in the data memories or similar data, or give this information to third parties, especially in the following situations:

- If the vehicle owner or lessee agrees
- If there is an official request from the police
- If a court or authorities request it

If legally permitted, Audi can also use the data for analysis of vehicle operation and safety performance or provide this data to third parties for research purposes.

Transmitted information

Data collection

Applies to: vehicles with data collection

Depending on the country, Audi may collect data for the following purposes, for example: offer and product optimization, public safety, provision of Audi connect remote vehicle services, and adaptation to customer expectations. For example, various technical function data, environmental data, driving data, and usage data will be collected for a specific purpose and forwarded to Audi. The data will be sent from the vehicle at the time the data was collected.

Applies to: MMI: You can find additional information about data collection in the MMI. Select on the home screen: **SETTINGS > General > Legal notes > About Audi connect.**

If you would like to deny data transmission to Audi, contact an authorized Audi dealer or authorized Audi Service Facility for more information. You also have the option to deactivate data transmission within the privacy settings.

Privacy settings

Applies to: vehicles with Audi connect

- ▶ Applies to MMI: Select on the home screen: **SETTINGS > Privacy mode settings**.
- ▶ To display additional information about the privacy settings and the associated symbols in the status bar, press ⓘ in the MMI.

Requirement: the ignition must be switched on.

Setting the maximum privacy settings

When the **Activate privacy mode** function is switched on, the data connection is deactivated or sending of data is restricted, but all safety-related, legal, or contractually required Audi connect services remain activated. The majority of the Audi connect services are deactivated.

When the function is switched off, the data connection will be available in order to use Audi connect services. After switching off the **Activate privacy mode** function, check the individual data categories as described under *Adjusting individual privacy settings*.

Adjusting individual privacy settings

In the MMI, you can adjust individually which data should be transmitted from the vehicle. If you switch on a data category, the data will be transmitted.

You can also deactivate individual services for your vehicle at my.audi.com if you are logged into the vehicle as the key user ⇒ *page 31*. These deactivated services will not be available in the vehicle. For additional information, visit my.audi.com.¹⁾

Note

You are responsible for all precautions taken for data protection, anti-virus protection, and protection against loss of data on mobile devices that are used to access the Internet through the Wi-Fi hotspot.

Tips

- The following interfaces are not affected by changes to the privacy settings: Bluetooth, Bluetooth Low Energy (BLE), Wi-Fi, smartphone interface, Near Field Communication (NFC), charging communication (high-voltage system), Electronic Toll Collect (ETC), On-Board Diagnostic System (OBD) if equipped.
- If the maximum privacy settings are switched on, your vehicle may not receive certificates and security updates for establishing a secure connection, depending on vehicle equipment. In order to receive security updates and certificates, switch the maximum privacy settings off for at least ten minutes every three months. Make sure that your vehicle is connected to the Internet. A symbol in the MMI status bar indicates if the required data connection is available ⇒ *page 23*.
- If the transmission of data is limited, it will have the following effects on the exchange of data for Audi connect services and emergency calls, if equipped:
 - The emergency call function will remain available without restrictions and will continue to transmit data.
 - If an online roadside assistance call is initiated, no data will be transmitted, but a call will be made.
 - Stored destinations (favorites, last destinations) are only stored in the vehicle. If you allow transmission of data again, these destinations will be synchronized via the myAudi account. To prevent synchronization of destinations, delete the destinations before you allow data to be transmitted again.

Audi connect

Applies to: vehicles with Audi connect Infotainment

Audi collects, uses, stores and shares your personal information, such as contact data, vehicle ▶

¹⁾ In certain countries.

data, usage data, driving data and precise geolocation, in order to provide you with the products and services you have purchased or requested, and for a number of other purposes, for example, to track quality issues, to performance and safety, to meet our internal compliance or legal requirements and to market to customers and potential customers. For a more complete list of the data we collect, how we use it and with whom we share it, please visit your Audi national/sales region website at www.audi.com.

The collection, use and sharing may vary depending on your model and model year, your subscription status, or the service offering. For example, collection, use and sharing may vary between Audi connect services, if you have designated a key user, or if you are driving a model equipped with persistent data logging. Please review the complete Privacy Statement to understand our data handling practices with respect to a particular service.

You can find additional information about our data privacy practices in your MMI.

- ▶ Applies to: MMI: On the home screen, select: **SETTINGS > General > Legal notes > About Audi connect.**

Information about our privacy practices in conjunction with the mobile Audi connect application can be found in the Application's Privacy Statement.

For additional information about the privacy practices relating to Audi connect, myAudi, or other websites, applications or online services as well as your obligations with respect to using these services, and for additional information regarding Audi connect terms and conditions, please visit your Audi national/sales region website at www.audi.com.

Accessories and technical changes

Warranty

Your vehicle is covered by various warranties:

- New Vehicle Limited Warranty
- Limited Warranty Against Corrosion Perforation
- High-Voltage System Limited Warranty
- Applies to: USA models: Kansas Safety Belt Limited Warranty

You can find detailed information in your Warranty & Maintenance Booklet or on the applicable website:

- Applies to: USA: maintenance.audiusa.com
- Applies to: Canada: www.audimaintenance.ca or www.audimaintenance.ca/#/search/fr

Audi Literature Shop

Service information is made available as soon as possible after a model is introduced and can be ordered in the Audi Literature Shop: <http://literature.audiusa.com>

Driving in other countries

Government regulations in the United States and Canada require motor vehicles to comply with emissions regulations and safety standards. Therefore, vehicles that were produced for the U.S. and Canadian markets are different from vehicles produced for other countries.

If you plan to use your vehicle outside of the United States or Canada, it is possible that:

- Proper maintenance and repair work may not be possible because special service equipment, tools, or measuring devices needed for your vehicle may not be available.
- Replacement parts may not always be available.
- Navigation systems for vehicles built for the U.S.A. and Canada will not necessarily work in Europe, and may not work in other countries.

Note

Audi is not liable for damage to the vehicle resulting from these country-specific differences.

Maintenance, repairs, and technical modifications

Observe the safety precautions ⇒ *page 229, General information* and ⇒ *page 271, Raising the vehicle*.

General information

Due to the increasing complexity of technology in these vehicles, as well as the safety and environmental standards that apply, you can only perform a very limited amount of repairs and modifications to the vehicle yourself.

Proof of maintenance work may be required to submit a claim within the warranty period.

We recommend that you have your vehicle serviced by an authorized Audi dealer or authorized Audi Service Facility and that Audi Genuine Parts and Audi Genuine Accessories are used. This helps to ensure that your vehicle's functionality, performance, and safety are not impaired.

Maintenance and repairs

Your vehicle was designed to help keep maintenance requirements to a minimum. Some regular maintenance is required to help ensure that your vehicle runs in a safe, economical, and reliable manner. Please refer to your Warranty & Maintenance Booklet for more detailed information about vehicle maintenance.

When operating the vehicle under more extreme operating conditions, for example when outside temperatures are very low or in very dusty environments, certain maintenance should be performed between the specified intervals.

Usually maintenance and repair work requires special tools, measuring devices, and other equipment that is available to trained vehicle technicians in order to help ensure that your vehicle and all of its systems operate correctly, ►

reliably, and safely. Performing work on the vehicle incorrectly can impair the operation and reliability of your vehicle and may void one or more of your vehicle's warranties.

Technical Modifications

Interference with electronic components, their software, the wiring, and data transfer may cause malfunctions. Because of the way electronic components are interconnected, such malfunctions can also impair systems that are not directly involved. This means that you risk both a substantial reduction in the operational safety of your vehicle and increased wear of vehicle components.

Some convenience functions, such as the convenience turn signal function, individual door opening function, and displays, can be reprogrammed using special workshop equipment. If functions are reprogrammed, the information and descriptions about these functions in this Owner's Manual may no longer apply to the changed functions. Audi recommends that an authorized Audi dealer or authorized Audi Service Facility perform and verify any reprogramming procedures.

WARNING

Maintenance work, repairs, or technical modifications to the vehicle (such as installing additional equipment) that is not performed correctly can cause serious injuries and increase the risk of an accident.

WARNING

The front compartment in any vehicle is a potentially dangerous area and can cause serious personal injury.

- Always use extreme caution when performing any work in the front compartment. Always follow commonly accepted safety practices and use common sense. Never risk personal injury.
- Never perform any work in the front compartment unless you know exactly how to carry out the job and have the correct technical information and the correct tools and equipment.

- If you are uncertain about what to do, have the work performed by an authorized Audi dealer, an authorized Audi Service Facility, or another qualified workshop. Serious personal injury may result from improperly performed work.

Note

- Maintenance work, repairs, or technical modifications to the vehicle (such as installing additional equipment) that is not performed correctly can cause vehicle damage.
- The New Vehicle Limited Warranty does not cover damage or malfunctions if the recommended intended use of the vehicle and maintenance measures listed in the Audi Owner's Manual and the Warranty & Maintenance Booklet were not followed.
- If emergency repairs must be performed, take your vehicle to an authorized Audi dealer or authorized Audi Service Facility as soon as possible.
- Audi is not liable for damage to the vehicle resulting from failure to comply with these guidelines.

For the sake of the environment

- Regular maintenance can help protect the environment.
- Technical modifications to the vehicle may have a negative affect on energy use.

Tips

Because of your vehicle's aluminum body design, all service and repair procedures affecting the body should be performed by an authorized Audi dealer or authorized Audi Service Facility, who will perform the work according to Audi factory specifications. Only Audi Genuine Parts are used when Audi experts perform repair or service procedures. Failure to use Audi Genuine Parts or Audi Genuine Accessories or performing repairs incorrectly may result in severe vehicle damage, such as corrosion.

Accessories and parts

Consult with an authorized Audi dealer or authorized Audi Service Facility before purchasing accessories or replacement parts. Audi recommends having your vehicle serviced by an authorized Audi dealer or authorized Audi Service Facility and using Audi Genuine Parts and Audi Genuine Accessories.

Audi does not endorse the use of products and accessories that it has not evaluated, even if the product is approved by a certified testing agency or government agency.

Radio communications equipment

A correctly-installed exterior antenna is required for operating radio equipment in the vehicle. Otherwise, the increased electromagnetic waves can cause malfunctions in the vehicle. Observe the regulations in the country where the vehicle is being operated and the instructions from the radio equipment manufacturer.

An authorized Audi dealer or authorized Audi Service Facility can inform you about installation options and radio communications equipment.

WARNING

- Installing unapproved accessories or incorrect replacement parts can cause vehicle damage and can increase the risk of an accident.
- Never attach accessories, such as telephone holders or cup holders, to the airbag covers or within the airbag deployment zone, because this increases the risk of injury if the airbag deploys.
- On vehicles that have factory-installed license plate brackets on the front of the vehicle, the brackets may only be replaced with ones that are the same size and made of the same material. Do not install any license plate brackets on the front of vehicles that do not have factory-installed brackets. Otherwise, the function of the system could be impaired.

Note

License plates or license plate holders in the front area must be installed by an authorized Audi dealer or authorized Audi Service Facility that will perform the work according to Audi factory specifications. Performing procedures incorrectly can lead to vehicle damage.

Reporting Safety Defects

Applicable to U.S.A.

If you believe that your vehicle has a defect which could cause a crash or could cause injury or death, you should immediately inform the National Highway Traffic Safety Administration (NHTSA) in addition to notifying

Audi of America, Inc.
2200 Ferdinand Porsche Drive
Herndon, VA 20171

If NHTSA receives similar complaints, it may open an investigation, and if it finds that a safety defect exists in a group of vehicles, it may order a recall and remedy campaign. However, NHTSA cannot become involved in individual problems between you, your dealer, or Audi of America, Inc.

To contact NHTSA, you may call the Vehicle Safety Hotline toll-free at 1-888-327-4236 (TTY: 1- ▶

800-424-9153); go to <http://www.safercar.gov>;

or write to:

Administrator NHTSA
1200 New Jersey Ave.,
S.E. West Building
Washington, DC
20590.

You can also obtain other information about motor vehicle safety from <http://www.safercar.gov>.

Applicable to Canada

If you live in Canada and you believe that your vehicle has a defect that could cause a crash, injury or death, you should immediately inform Transport Canada, Defect Investigations and Recalls. You should also notify Audi Canada.

Canadian customers who wish to report a safety-related defect to Transport Canada, Defect Investigations and Recalls, may either call Transport Canada toll-free at:

Tel.: 1-800-333-0510 or

Tel.: 1-819-994-3328 (Ottawa region and from other countries)

TTY for hearing impaired:

1-888-675-6863

or contact Transport Canada by mail at:

Transport Canada
Motor Vehicle Safety Investigations Laboratory
80 Noel Street
Gatineau, QC
J8Z 0A1

For additional road safety information, please visit the Road Safety website at:

English:

<http://www.tc.gc.ca/eng/motorvehiclesafety/menu.htm>

French:

<http://www.tc.gc.ca/fra/securiteautomobile/menu.htm>

Technical data

Identification data

Vehicle Identification Number

The Vehicle Identification Number (VIN) is located in the following areas:

- Applies to MMI: Select on the home screen: **VEHICLE > Settings & Service > Vehicle information**.
- At the front behind the windshield
- Stamped into the luggage compartment under the cargo floor cover near the rear bench seat

Notes about technical data

The values may vary based on special equipment as well as market-specific equipment and measuring methods.

Please note that the specifications listed in the vehicle documentation always take precedence.

Tips

Any technical data that is missing was not available at the time of printing.

Vehicle data

Dimensions

	Length (in (mm))	Width (in (mm))	Width across the mirrors (in (mm))	Height at curb weight (in (mm))
Q4	180.6 (4,588) - 180.8 (4,591)	73.4 (1,865)	83.0 (2,108)	64.7 (1,642) - 64.7 (1,644)
Q4 Sportback	180.6 (4,588) - 180.8 (4,591)	73.4 (1,865)	83.0 (2,108)	64.0 (1,627) - 64.1 (1,628)

Capacities

	Approximate capacities
Windshield washer system	3.0 qt (2.8 L) / 3.2 qt (3 L)
Windshield/headlamp washer system*	6.0 qt (5.7 L) / 6.3 qt (6.0 L)

A/C system refrigerant oil

The exact type and amount of refrigerant oil in the A/C system is specified on the sticker on the refrigerant compressor.

	Approximate capacities	Tolerance
Refrigerant oil	120 / 200 g ^{a)}	+/- 10 g

^{a)} The specifications depend on vehicle equipment.

Weights

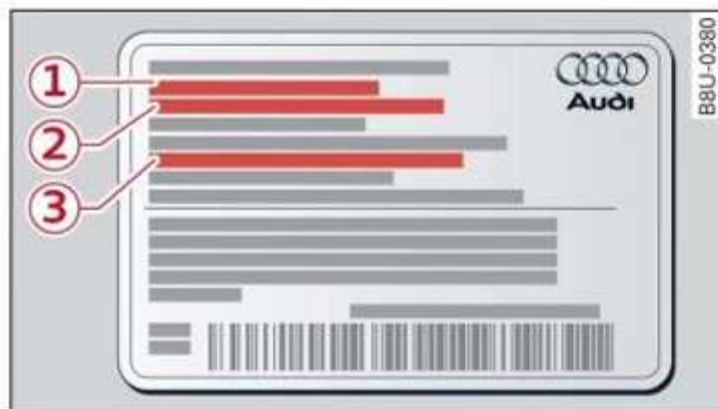

Fig. 176 Safety certificate

Gross Vehicle Weight Rating (GVWR)

The maximum permitted total weight ① of the vehicle is listed on the safety certificate on the side area of the door or on the driver's door pillar.

Trailer load

	Trailer with brakes up to 12% incline	Tongue weight on trailer ball hitch
Q4 e-tron 40	2,205 lbs (1,000 kg)	220 lbs (100 kg)
Q4 e-tron 50	2,646 lbs (1,200 kg)	265 lbs (120 kg)

Notes on the motor data

Applies to: Vehicles with 220 kW/295 hp

	Max. power output ^{a)}
Q4 e-tron 50, Q4 Sportback e-tron 50	220 kW (UN GTR)
	295 hp (SAE)

^{a)} Maximum power, which can be called up for a maximum of 30 seconds, is determined in accordance with the test standards noted above. Up to 25 kW / 34 hp of maximum power is accounted for by overboost.

The power available in a particular driving situation depends on a number of variables such as outside temperature and temperature, charge level and condition or physical aging of the high-voltage battery.

To achieve maximum power availability, including overboost, certain conditions must be in place, in particular a high-voltage battery temperature of between 73 °F and 122 °F (23 °C and 50 °C) and a charge level greater than 88 %.

Deviations in particular from the aforementioned parameters can lead to a reduction in perform-

Gross Axle Weight Rating (GAWR)

The maximum permitted load on the front axle ② or the rear axle ③ is listed on the safety certificate on the side area of the door or on the driver's door pillar.

Load

The maximum permitted load is listed on the tire pressure label on the driver's door pillar.

Roof load

The maximum permissible roof load is 165 lbs (75 kg).

ance or even to the unavailability of the overboost.

The battery temperature can, to a certain extent, be influenced indirectly via the air conditioning function. The state of charge can be set in the vehicle, among other settings. The power currently available is shown in the vehicle's power meter display.

In order to preserve the usable capacity of the high voltage battery the best possible, it is recommended setting a charging target of the battery of 80 % for a daily use (which can be switched to 100 % before long distance journeys, for example).

Other information

Brands and licenses

This manual does not contain any symbols, such as ® or ™, to identify trademarks or registered trademarks. However, the absence of these symbols does not constitute a waiver of any rights associated with these names.

Apple, iPhone, iPod touch, Apple CarPlay, Lightning, and iTunes Radio are trademarks of Apple Inc.

Other product and manufacturer names may be trademarks of their respective owners.

Disposal instructions

General information

Follow the legal regulations for disposal of electrical/electronic devices and the vehicle that are applicable in your country, as well as the information that follows.

Batteries

Handling batteries that contain lithium (Li) requires special care. For example, they must not be overheated or damaged. Battery components can be harmful to human and animal health and can accumulate in the environment. To reduce this risk, follow the legal regulations for disposal of batteries that are applicable in your country.

Vehicle

Certain components in your vehicle such as undeployed airbag modules, pretensioners and remote control batteries may contain Perchlorate Material – special handling may apply, See www.dtsc.ca.gov/hazardouswaste/perchlorate. When the vehicle or parts of the restraint system including airbag modules and safety belts with pretensioners are scrapped, all applicable laws and regulations must be observed. Your authorized Audi dealer is familiar with these requirements and we recommend that you have your dealer perform this service for you.

Declaration of compliance for telecommunications equipment and electronic systems

Your vehicle may be equipped with various radio systems, depending on vehicle equipment. The manufacturer is not liable for radio malfunctions that are caused by unauthorized changes to the equipment.

FCC Part 15.19

This device complies with part 15 of the FCC Rules. Operation is subject to the following two conditions: (1) This device may not cause harmful interference, and (2) this device must accept any interference received, including interference that may cause undesired operation.

FCC Part 15.21

Changes or modifications not expressly approved by the party responsible for compliance could void the user's authority to operate the equipment.

RSS-Gen

This device contains licence-exempt transmitter(s)/receiver(s) that comply with Innovation, Science and Economic Development Canada's licence-exempt RSS(s). Operation is subject to the following two conditions:

- (1) This device may not cause interference; and
- (2) This device must accept any interference, including interference that may cause undesired operation of the device.

Class B devices

This equipment has been tested and found to comply with the limits for a Class B digital device, pursuant to part 15 of the FCC Rules. These limits are designed to provide reasonable protection against harmful interference in a residential installation. This equipment generates, uses and can radiate radio frequency energy and, if not installed and used in accordance with the instructions, may cause harmful interference to radio communications. However, there is no guarantee ►

that interference will not occur in a particular installation. If this equipment does cause harmful interference to radio or television reception, which can be determined by turning the equipment off and on, the user is encouraged to try to correct the interference by one or more of the following measures:

- Reorient or relocate the receiving antenna.
- Increase the separation between the equipment and receiver.
- Connect the equipment into an outlet on a circuit different from that to which the receiver is connected.
- Consult the dealer or an experienced radio/TV technician for help.

This Class B digital apparatus complies with Canadian ICES-003.

Tips

Additional information, updates, and supplements about the radio systems or product names are based on the vehicle equipment and country can be found on the following website: www.audi.com/generalinfo

A

- A/C cooling mode 85
- A/C system refrigerant oil 289
- ABS
 - refer to Anti-Lock Braking System (ABS)* . . . 102
- Accelerator pedal 93
 - also refer to Accelerator pedal* 93
- Accessories 287
- Active combination filter 84
- Adaptive cruise assist 141
 - Cleaning the sensors 263
- Adaptive cruise control
 - Predictive control 146
- Adaptive dampers 100
- Adaptive speed assist 141
 - also refer to Adaptive cruise assist* 141
- Adjusting the air distribution 85
- Adjusting the brightness 53
- Adjusting the recuperation 93
- Adjusting the sound 225
- Adjusting the temperature 85
- Adjusting the volume 30
- Adjusting the volume (announcements) 225
- Airbag system 68
- Alarm system
 - refer to Anti-theft alarm system* 36
- All-weather lights 49
- All season tires 256
- All wheel drive
 - refer to quattro* 102
- Amazon Alexa integration
 - Media playback 213
 - Operation 28
- Android Auto
 - refer to Smartphone interface* 222
- Anti-Lock Braking System (ABS) 102
- Anti-Slip Regulation 102
- Anti-theft alarm system 36
- Apple CarPlay
 - refer to Smartphone interface* 222
- Aspect ratio
 - Video 217
- ASR
 - refer to Anti-Slip Regulation* 102
- Audi adaptive light 49
- Audi connect
 - refer to connect* 185, 186
- Audi connect Remote & Control 187
- Audi drive select 100
- Audi e-tron Charging System Compact 118
 - Adjusting the charging power level 119
 - Changing or attaching the power cable 123
 - Securing 124
 - Status and malfunction indicators 119
- Audio files 214
- Audi Online Owner's Manual 6
- Audi phone box 176
- Audi pre sense 153
 - Messages 156
 - Safety measures 154
- Audi pre sense front 154
- Audi virtual cockpit
 - refer to Instrument cluster* 14
- Augmented reality head-up display 26
- AUTO
 - Automatic climate control system 85
 - Automatic headlights 49
- Auto Lock (central locking) 33
- Automatic climate control system 84
- Automatic luggage compartment lid 40, 42
- Automatic transmission 92
- Automatic wipe/wash system 56
- Auxiliary climate control 88
- Average consumption 16
- Average speed 16

B

- Band
 - refer to Frequency band* 205
- Battery
 - Charging (12 volt vehicle battery) 238
 - High-voltage battery 105
 - Vehicle battery (12 volt) 236
 - Winter operation (12 volt vehicle battery) 236
- Battery protection function 113
- Battery (mobile device)
 - Charging via USB 177, 213
 - Wireless charging 177
- Battery (vehicle)
 - refer to High-voltage battery* 105
- Blower 85

- Bluetooth
 - Audio player 212
 - Connecting a device 227
 - Connecting a mobile phone 174
 - Deleting a device 227
 - Device overview 227
 - Disconnecting a device 227
 - Displaying profiles 227
 - Selecting a device 227
 - Specifying a favorite 227
 - Brake fluid
 - Checking the brake fluid level 234
 - Brakes 95
 - Brake fluid 234
 - Emergency braking function 98
 - Hot 98
 - New brake pads 95
 - Brands 291
 - Break-in security feature 36
 - Breaking in
 - New brake pads 95
 - New tires 248
 - Bulb replacement 280
 - Business address 200
- C**
- California Proposition 65 Warning 229
 - Battery specific 237
 - Call list 178
 - Cameras
 - Coverage areas 130
 - Locations 132
 - Capacities 289
 - Cargo floor 82
 - Car key 37
 - Car wash 261
 - Cell phone
 - refer to Telephone* 174
 - Cell phone compartment
 - refer to Audi phone box* 176
 - Center display
 - refer to Multi Media Interface* 20
 - Central locking 33
 - Auto Lock 33
 - Convenience key 38
 - Convenience opening and closing 44
 - Luggage compartment lid 40
 - Mechanically unlocking and locking 35
 - Messages 35
 - Remote control key 38
 - Setting 34
 - Vehicle key 38
 - Central locking switch 35
 - Certification 291
 - Changing light bulbs 280
 - Charge points (battery) 232
 - Charging
 - refer to Power sources* 79
 - Charging cable for household or industrial sockets
 - refer to Audi e-tron Charging System Compact* 118
 - Charging clip
 - refer to Wall mount clip* 124
 - Charging display 110
 - Charging mode 113
 - Charging system
 - refer to Audi e-tron Charging System Compact* 118
 - Charging time 107
 - Charging time frame
 - refer to Preferred charging time* 116
 - Charging wirelessly 177
 - Child safety lock
 - Climate control system controls in the rear 43
 - Power windows 43
 - Rear doors 43
 - Child safety seats 73
 - Securing to the top tether anchor 77
 - Securing with a safety belt 76
 - Securing with LATCH 75
 - Cleaning 261
 - Cleaning artificial leather 264
 - Cleaning carbon components 263, 265
 - Cleaning controls 264
 - Cleaning decorative parts and trim 263, 264
 - Cleaning microfiber 264
 - Cleaning plastic parts 264
 - Cleaning rubber seals 263
 - Cleaning textiles 264

- Climate control system 84
 - also refer to* Automatic climate control system 84
 - Climate control system controls in the rear
 - Child safety lock 43
 - Closing
 - Automatic luggage compartment lid 40
 - Convenience closing 44
 - Hood 230
 - Luggage compartment lid 40
 - Luggage compartment lid with foot motion 42
 - Panoramic glass roof 45
 - Sunshade (roof) 45
 - Windows 44
 - Cockpit dimming 53
 - Cockpit (overview) 9
 - Comfort auxiliary air conditioning 89
 - Coming to a stop 91
 - Compartments 80
 - Compass in the mirror 58
 - Compliance 291
 - Conference call 181
 - Configuration wizard 20
 - connect 185
 - Data plans 188
 - Data Privacy 283
 - Emergency call 190
 - Infotainment 186
 - Infotainment services 186
 - Online roadside assistance 191
 - Vehicle control services 187
 - Connected devices 227
 - Connections
 - refer to* Media 212, 214
 - Consumer information 285
 - Consumption
 - Saving 94
 - Contacts
 - Importing and exporting 182
 - Updating in the MMI 182
 - also refer to* Directory 179
 - Convenience key 33
 - also refer to* Vehicle key 37
 - Convenience opening and closing
 - Windows or panoramic glass roof 44
 - Cooling mode 85
 - Cooling system
 - Adding coolant 233
 - Checking the coolant level 233
 - Coolant 232
 - Cornering light 49
 - Cruise control system 138
 - Cup holders 79
 - Current consumption 16
- ## D
- Data module
 - Serial number (IMEI) 182
 - Data plans 188
 - Data Privacy 283
 - Date 16
 - Setting 225
 - Daytime running lights 49
 - Declaration of compliance 291
 - Defrosting the windows 85
 - Defrosting (windows) 85
 - Demo mode
 - refer to* Presentation mode 203
 - Determining correct load limit 255
 - Device overview 227
 - Digital compass 58
 - Dimensions 289
 - Dimming the exterior mirrors 54
 - Dimming the rearview mirror 54
 - Directory 179
 - Business card 180
 - Display
 - Cleaning 264
 - Displaying tool tips 20
 - Disposal 285
 - Distance 16
 - Distance warning 151
 - Doors
 - Child safety lock 43
 - Door contact switch 53
 - Mechanically unlocking and locking 35
 - Drive
 - Audi drive select 100
 - Driver assistance menu 132
 - Driver availability recognition 93
 - Driver information system 14

Drives		Emergency flashers	52
<i>refer to</i> Media	212, 214	Emergency mode	93
Drive select		Emergency operation	
<i>refer to</i> Audi drive select	100	Doors	35
Drive system	93	Panoramic glass roof	45
Breaking in	93	Energy	
Emergency off	90	Current consumption	16
Switching on and off	90	Energy recovery	93
Driving down hills	98	Engine braking effect	
Driving program	150	<i>refer to</i> Recuperation	93
Driving through water	99	Engine compartment	
Driving time	16	<i>refer to</i> Front compartment	229
Driving tips		Engine start system	91
Driving through water	99	Entering a destination	193
Efficient driving	94	Destination from the map	196
Uphill and downhill	98	Entry/exit lighting	51
Driving up hills	98	ESC	
Dust filter		<i>refer to</i> Electronic Stabilization Control	102
<i>refer to</i> Active combination filter	84	ESC Sport	103
E		eSIM	
E-mail	183	<i>refer to</i> Embedded SIM card	186
EDL		Event Data Recorder (EDR)	281
<i>refer to</i> Electronic Differential Lock	102	Exit warning	158
EDR		Exterior antenna	177
<i>refer to</i> Event Data Recorder (EDR)	281	Exterior lighting	49
Efficiency assist	139	Exterior mirrors	54
Predictive control	146	External voice operation	28
Electrical system	235	F	
Electric drive system	93	Factory default settings	
Electric motor		Multi Media Interface	226
Coolant	232	Fastest route	193
Electric range	201	Favorites	22
Electromechanical parking brake	97	Bluetooth	227
Electronic Differential Lock	102	Navigation	194
Electronic immobilizer	37	Podcast	210
Electronic Stabilization Control	102	Telephone	179
Embedded SIM card	186	Federal Communications Commission (FCC)	291
Emergency assist	159	File formats (media drives)	218
Emergency assistance	268	Floor mat	60
Towing eye for professional towing serv- ices	275	Folding the center armrest	82
Emergency braking function	98	Folding the rear seats	82
Emergency call	181, 190	For the sake of the environment	
Emergency charging	111, 112	Leaks	230

- Forward gear
refer to Gears 92
- Free text search
 Media 217
 Radio 207
- Freeze protection
 Coolant 232
 Windshield washer system 239
- Frequency band 205
also refer to Frequency band 205
- Front center armrest 62
- Front collision warning
refer to Audi pre sense front 153
- Front compartment
 Overview 232
 Safety precautions 229
- Front wiper blades
 Changing 57
 Cleaning 57
- Fuses
 Assignment 279
 Replacing 278
- G**
- Garage door opener 45
- Garment hooks 80
- GAWR
refer to Gross Axle Weight Rating (GAWR) . 290
- Gears 92
- Glossary of tire and loading terminology ... 244
- Glove compartment 80
- Gross Axle Weight Rating (GAWR) 290
- Gross Vehicle Weight Rating (GVWR) 290
- GVWR
refer to Gross Vehicle Weight Rating (GVWR) 290
- H**
- Hands-free 175
- Hands Free Profile 175
- Head-up display
 Adjusting 26
 Adjusting the brightness 53
 Operating 26
- Headlamp washer system
 Capacities 289
- Headlight range control 49
- Headlights
 Cleaning 262
 Headlight range control 49
 Washer system 56
 Washer system (filling washer fluid) 239
- Head restraints 64
- Heated
 Rear window 86
 Seats 86
- Heated steering wheel 87
- Heating 84
- HFP
refer to Hands Free Profile 174
- High-voltage battery 105
 Activating the battery protection function . 113
 Advanced charging settings 116
 Audi e-tron Charging System Compact ... 118
 Automatically unlocking the charging connector 114
 Charge level display 14
 Charging 106, 109
 Charging display on the vehicle 110
 Charging equipment 116
 Charging methods 106
 Charging ports on the vehicle 106
 Charging time 107
 Connecting the charging cable 109
 Messages while driving 112
 Not running for long periods of time 108
 Opening the charging port door 109
 Plug & charge 115
 Quick charging 106
 Setting the charging target 113
 Setting the timer 114
 Transporting charging equipment 117
- High-voltage system 105
- High beams
 High beam assistant 50
- Highway lights 49
- Hill descent control 98
- Home
refer to Home address 200
 Home address 200

HomeLink		
<i>refer to</i> Garage door opener	45	
Home screen	19	
Hood	230	
Opening and closing the lid	230	
<i>also refer to</i> Hood	230	
Horn	9	
Hotspot		
<i>refer to</i> Wi-Fi	188	
I		
Idle		
<i>refer to</i> Gears	92	
Ignition		
Switching on and off	90	
Imbalance (wheels)	250	
Immediate charging mode	112, 113	
Immobilizer		
<i>refer to</i> Electronic immobilizer	37	
Indicator lights	10	
Inspection interval		
<i>refer to</i> Service interval display	239	
Instrument cluster	14	
Adjusting the layout	15	
Cleaning	264	
Engine code	228	
Malfunction	14	
Operating	14	
Service interval display	239	
Software information	228	
Switching tabs	14	
Switching the view	15	
Trip computer	16	
Vehicle functions	16	
Version information	228	
Intelligent search		
Navigation	193	
Interference-Causing Equipment Standard (ICES)	291	
Interior lighting	53	
Interior monitoring	36	
Intermittent mode (windshield wipers)	56	
International travel	188	
Internet		
<i>refer to</i> connect	185, 186	
Internet radio		
<i>refer to</i> Online radio	209	
iPhone		
<i>refer to</i> USB ports with charging function	213	
J		
Jump starting	272	
Jump start points		
<i>refer to</i> Charge points (battery)	232	
K		
Key	33, 37	
Convenience opening	44	
Key replacement	37	
Mechanical key	37	
PANIC button	37	
Replacing the battery	38	
Unlocking and locking	38	
Key user	32	
Kick-down	93	
L		
Lane assist		
<i>refer to</i> Lane departure warning	145	
<i>refer to</i> Lane guidance (Adaptive cruise assist)	145	
Lane departure warning	151	
Cleaning the camera area	263	
Lane guidance (Adaptive cruise assist)	145	
LATCH (securing child safety seats)	75	
Leather care and cleaning	265	
Legal information		
License subscriptions	228	
Software information	228	
Software licenses	228	
Version information	228	
License plate bracket	287	
Lifting points (vehicle jack)	271	
Light/rain sensor		
Headlights	49	
Intermittent mode (windshield wipers)	56	
Lighting	49	
Exterior	49	
Interior	53	

- Lights on the charging port
 refer to Charging display 110
 - Listening to music
 refer to Media 212, 214
 - Load 290
 - Local users 31
 - Locking and unlocking
 - By remote control 38
 - Using the lock cylinder 35
 - With the convenience key 38
 - Low beam headlights 49
 - LTE
 refer to Exterior antenna 177
 - Luggage
 - Luggage compartment lid 39
 - Luggage compartment 80
 - Cover 81
 - Increasing the size 82
 - Power sources 79
 - Tie-downs 82
 - also refer to* Luggage compartment 80
 - Luggage compartment lid 39
 - Closing button 40
 - General information 39
 - Manually unlocking 43
 - Opening and closing 40
 - Opening and closing with foot motion 42
 - Power opening and closing 40
 - Lumbar support 61, 62
- M**
- Maintenance 285
 - Maintenance intervals
 refer to Service interval display 239
 - Manually releasing the charging connector 111
 - Manual operation
 - Charging connector 111
 - Luggage compartment lid 41, 43
 - Map
 - Changing the map scale 196
 - Display 198
 - Operating 197
 - Selecting a destination 196
 - MAP
 refer to Message Access Profile 183
 - Map preview 195
 - Map update 201
 - Online 201
 - USB connection 202
 - Matrix LED headlights 50
 - Mechanical key 37
 - Media 212, 214
 - Supported formats 218
 - Media center 215
 - Memory function 68
 - Menu language
 refer to Setting the language 225
 - Menu paths 19
 - Message Access Profile 183
 - Messages 183
 - Mirror compass 58
 - Mirrors
 - Adjusting exterior mirrors 54
 - Dimming 54
 - Vanity mirror 55
 - MMI
 refer to Multi Media Interface 20
 - Mobile device
 refer to Telephone 174
 - Mobile device reminder signal 178
 - Mountain passes 98
 - Mountain roads 98
 - Multifunction steering wheel
 - Buttons 14, 30
 - Operating 14
 - Programming buttons 30
 - Voice recognition system 27
 - Multi Media Interface 20
 - Menus and symbols 21
 - Operating 18, 21
 - Switching on or off 20
 - Muting 30
 - myAudi 31, 186
 - myAudi navigation 192, 195
 - myAudi users 31
- N**
- Natural leather care and cleaning 265
 - Navigation 192
 - Better route 202
 - Changing the scale 196
 - Destination details 195

Favorites	200
<i>also refer to</i> Map	197
Navigation database	
Version information	228
Navigation (instrument cluster)	198
Neutral	97
NHTSA	287
Notification center	23

O

Odometer	16
Resetting	16
Office address	
<i>refer to</i> Business address	200
OFF (button)	84
On Board Diagnostic System (OBD)	281
Online map	
<i>refer to</i> Satellite map	200
Online Owner's Manual	6
Online radio	209
<i>also refer to</i> Online radio	209
Online roadside assistance	191
Online services	
<i>refer to</i> connect	185, 186
Online system update	226
Online traffic information	203
Opening	33
Automatic luggage compartment lid	40
Convenience opening	44
Hood	230
Luggage compartment lid	40
Luggage compartment lid with foot motion	42
Panoramic glass roof	45
Sunshade (roof)	45
Windows	44
Opening and closing	
<i>refer to</i> Unlocking and locking	33, 38
Opening the charging port door	109
Operating	
Head-up display	26
Instrument cluster	14
Multifunction steering wheel	14
Multi Media Interface	18, 21
Text input	24
Touch display	18
Voice recognition system	27

Options	
Media	217
Radio	210
Outside noise	94
Overview (cockpit)	9
Owner's Manual	
Accessing the digital version	6

P

Paint damage	263
PANIC button	37
PANIC function	37
Panoramic glass roof	45
Convenience opening and closing	44
Emergency closing	45
Park assist plus	170
Parking	91
Parking aid	161
Adjusting the volume	162
Automatic activation	161
Cleaning the sensors and camera	263
Park assist plus	170
Parking aid plus	161
Parking space search	168
Peripheral cameras	163
Rear cross-traffic assist	167
Rearview camera	163
Trailer view	165
Parking aid menu	133
Parking and maneuvering	161
Parking brake	
<i>refer to</i> Electromechanical parking brake ..	97
Parking lights	49
Pedals	93
Perchlorate	285
Peripheral cameras	163
Phone	
Connecting a second mobile device	175
Disconnecting a mobile device	176
Phonebook	
<i>refer to</i> Directory	179
PIN	
4-digit myAudi PIN	31
Protection	32

- Playback
 - Media 214
 - Radio 206
 - Plug & charge 115
 - Erasing contract information 115
 - Switching on and off 115
 - Troubleshooting 115
 - Podcast
 - refer to* Online radio 209
 - Polishing 263
 - Pollen filter
 - refer to* Active combination filter 84
 - Power meter 14, 16
 - Power sources 79, 213
 - Power windows 44
 - Malfunction 44
 - Power windows malfunction 44
 - Predictive control 146
 - Predictive messages 140
 - Predictive route guidance 199
 - Preferred charging time 116
 - pre sense
 - refer to* Audi pre sense 153
 - Presentation mode 204
 - Presets
 - Radio 208
 - Presets list
 - refer to* Presets 208
 - Pressure
 - Tire pressure monitoring system 259
 - Tires 252
 - Progressive steering 101
 - Protecting 263
 - Pyrotechnic elements 285
- Q**
- quattro 102
 - Selective wheel torque control 102
 - Quick charging 106
- R**
- Radio 205
 - Radio text 208
 - Station list 205
 - Radio communications equipment 287
 - Radio equipment 287
 - Radio Standards Specification (RSS) 291
 - Rain/light sensor
 - Headlights 49
 - Intermittent mode (windshield wipers) 56
 - Random
 - refer to* Shuffle 216
 - Range mode 94
 - Range (electric) 201
 - Reading lights 53
 - Rear cross-traffic assist 167
 - Rear lid
 - refer to* Luggage compartment lid 40
 - Rearview camera 163
 - Rear window defogger 86
 - Rear wiper blades
 - Changing 58
 - Cleaning 58
 - Recirculation mode 85
 - Recuperation 17, 93
 - Refrigerant oil 289
 - Remote access authorization (key user) 32
 - Remote control
 - Garage door opener 45
 - Remote control key 37
 - Convenience opening 44
 - Key replacement 37
 - LED 38
 - PANIC function 37
 - Replacing the battery 38
 - Unlocking and locking 38
 - also refer to* Vehicle key 37
 - Removing the caps (wheel bolts) 271
 - Repairs 285
 - Replacement key 37
 - Replacement parts 287
 - Replacing the battery
 - 12 volt vehicle battery 236
 - Vehicle key 38
 - Reporting Safety Defects 287
 - Reverse gear
 - refer to* Gears 92
 - Rims 256
 - Cleaning 263
 - Rolling 91

Rolling ability		
Electromechanical parking brake	97	
"N" selector lever position	92	
Roof		
<i>refer to</i> Panoramic glass roof	45	
Roof load	290	
Roof rack	83	
<i>also refer to</i> Roof rack	83	
Route guidance		
Stopping	197	
<i>also refer to</i> Navigation	192	
Route planner (e-tron)	196	
Running direction (tires)	272	
 S		
Safety belts	65	
Cleaning	264	
Locking	76	
Securing child safety seats	76	
Satellite map	200	
Screen		
<i>refer to</i> Touch display	18	
Search function		
<i>refer to</i> Free text search	207, 217	
<i>refer to</i> Intelligent search	193	
Seat heating	86	
Seats		
Adjusting	61, 62	
Cleaning	264	
Folding	82	
Head restraints	63	
Memory function	68	
Storing a seat profile	68	
Selecting a source		
Media	214	
Radio	206	
Selector lever	92	
Selector lever position		
<i>refer to</i> Gears	92	
Self-learning navigation		
<i>refer to</i> Predictive route guidance	199	
Sensors		
Coverage areas	130	
Locations	132	
Service interval		
<i>refer to</i> Service interval display	239	
Service interval display	239	
Setting measurement units	225	
Settings	225	
Announcements and tones	225	
Bluetooth	225	
Date and time	225	
Directory	182	
E-mail	183	
Language	225	
Measurement units	225	
Media	218	
Navigation	203	
Radio	210	
Sound	225	
System	225	
Telephone	182	
Text messages	183	
Time zone	225	
Wi-Fi hotspot	188	
Setting the charging target	113	
Setting the language	225	
Setting the time	225	
Shuffle	216	
Side assist	156	
Cleaning the sensors	263	
SIM card	186	
Sliding/tilting sunroof		
<i>refer to</i> Panoramic glass roof	45	
Smart Favorites		
<i>refer to</i> Presets	208	
Smartphone		
<i>refer to</i> Telephone	174	
Smartphone interface	222	
Legal information	228	
Snow chains	257	
Socket		
<i>refer to</i> Power sources	79	
Software information		
Legal information	228	
Software version (MMI)		
Version information	228	
Sound		
<i>refer to</i> Adjusting the sound	225	
Speed limit information		
<i>refer to</i> Traffic sign recognition	134	
Speed limits		
<i>refer to</i> Traffic sign recognition	134	

- Speedometer 14
- Speed warning system 134
- Start A/C after unlocking 88
- Starting to drive 91
- Steering 101
- Audi drive select 100
- also refer to* Steering 101
- Steering wheel
- Adjusting 63
- Adjusting manually 63
- Steering wheel heating 87
- also refer to* Multifunction steering wheel . . . 14
- Steps for determining correct load limit . . . 255
- Stopover (navigation) 196
- Stopping 91
- Storage 80
- Stored stations
- refer to* Presets 208
- Sunshade
- Roof 45
- also refer to* Panoramic glass roof 45
- Sun visors 55
- Supplying the battery from an external source 272
- Suspension 100
- Audi drive select 100
- Swapping calls 181
- Symbols
- Charging equipment 116
- Media 216
- Navigation 197
- Radio 206, 207
- also refer to* Indicator lights 10
- SYNC (button) 85
- System settings 225
- T**
- Tail lights
- Cleaning 262
- Technical data 289
- Technical modifications 285
- Telephone 174
- Accepting/ending a call 180
- Audi phone box 176
- Charging the battery (USB) 177
- Charging the battery (wireless) 177
- Connecting a mobile phone 174
- Dialing a number 180
- Exterior antenna 177
- Mobile device reminder signal 178
- Options during a phone call 181
- Playing music 212
- Temperature display
- Outside temperature 16
- Text input 24
- Text messages 183
- also refer to* Text messages 183
- Themes 221
- Tie-downs 82
- Tightening specification
- Wheel bolts 272
- Tightening specification (wheel bolts) 272
- Time 16
- Timer charging mode 112, 113
- Timer (high-voltage battery) 114
- Tire Mobility System (tire repair set) 268
- Tires 241
- Changing 270
- Labeling 242
- Load index 242
- Low-profile tires 257
- Manufacture date 242
- Repair set 268
- Service life 250
- Speed rating 242
- Tire pressure 252
- Tire pressure monitoring system 258, 259
- Tire pressure table 253
- Tire pressure (trailer mode) 125
- Treadwear indicators 250
- Unidirectional 243, 272
- Uniform tire quality grading 257
- Tires and wheels
- Glossary of tire and loading terminology . . 244
- Tires and vehicle load limits 254
- Tools 268
- Top tether anchor (securing the child safety seat) 77
- Touch display
- Adjusting the brightness 20
- Operating 18
- Towing 274
- Towing loop 276

Towing protection monitoring	36	Raising	271
TPMS		Securing	91
Tire pressure monitoring system	259	Starting	90
Traffic information	202	Unlocking and locking	38
Online traffic information	203	Vehicle care	261
Traffic light information	136	Vehicle control services	187
Traffic sign recognition	134	<i>also refer to Audi connect Remote & Control</i>	187
Traffic signs	137	Vehicle Identification Number	289
Trailer load	290	Vehicle Identification Number (VIN)	
Trailer mode		<i>refer to Vehicle Identification Number</i> ...	289
Trailer hitch	126	Vehicle key	33, 37
Trailer towing	125	Vehicle sound	94
Tongue weight	125	Vehicle tool kit	268
Trailer load	125	Ventilation	84
Trailer view	165	VIEW button	14
Trip computer	16	VIN	
Turn signals	50	<i>refer to Vehicle Identification Number</i> ...	289
U		Voicemail	180
Uniform tire quality grading	257	Voice recognition system	27
Unlocking and locking	33	External	28
By remote control	38	Operating	27
Using the lock cylinder	35	W	
With the central locking switch	35	Wall mount clip	124
With the convenience key	38	Warning lights	
Update (software)	226	<i>refer to Indicator lights</i>	10
USB adapter	213	Washing matte finish paint	261
USB drive		Wave band	
Supported types/formats	218	<i>refer to Frequency band</i>	205
USB port	79	Weights	290
USB ports with charging function	213	Wheel bolts	256
USB stick		Changing a tire	270
<i>refer to USB ports with charging function</i> .	213	Wheels	241
Users		Cleaning	263
Local users	31	Glossary of tire and loading terminology ..	244
myAudi users	31	Replacing	270
V		Tire pressure monitoring system	259
Vanity mirror	55	Tires and vehicle load limits	254
Vehicle		Wi-Fi	
Care/cleaning	261	Hotspot settings	188
Dimensions	289	Using a hotspot	186
Identification data	289	Window and mirror heating	89
Out of service	267	Windows	
Parking	91	Child safety lock	43
		Cleaning and removing ice	264

Convenience opening and closing	44
Opening and closing	44
Power windows	44
Windshield	
Cleaning	56
<i>also refer to</i> Windshield	56
Windshield washer system	56, 239
Capacities	289
Windshield wipers	56
Winter operation	
Auxiliary climate control	88
Car washes	261
Cooling system	232
Defrosting the windows	85
Rear window defogger	86
Removing ice from windows	264
Seat heating	86
Snow chains	257
Steering wheel heating	87
Tires	256
Vehicle battery (12 volt)	236
Windshield washer system	239
Winter tires	256
Wireless Android Auto	
<i>refer to</i> Smartphone interface	222
Wireless Apple CarPlay	
<i>refer to</i> Smartphone interface	222
Work	
<i>refer to</i> Business address	200

These instructions may not be reproduced or translated in whole or in part without written consent of AUDI AG. All rights reserved by AUDI AG.

© 2023 AUDI AG



For the sake of the environment

Printed on eco-friendly paper (bleached without chlorine, recyclable).

Owner's Manual
English North America 06.2023
89A012721BG



89A012721BG

www.audi.com